



# SF52

## Dew-Point Transmitter

### User's Manual



Please fill out the form(s) below for each instrument that has been purchased.

Use this information when contacting Michell Instruments for service purposes.

Transmitter	
Code	
Serial Number	
Invoice Date	
Location of Instrument	
Tag No	

Transmitter	
Code	
Serial Number	
Invoice Date	
Location of Instrument	
Tag No	

Transmitter	
Code	
Serial Number	
Invoice Date	
Location of Instrument	
Tag No	



## SF52 Transmitter

For Michell Instruments' contact information please go to  
[www.michell.com](http://www.michell.com)

© 2015 Michell Instruments

This document is the property of Michell Instruments Ltd. and may not be copied or otherwise reproduced, communicated in any way to third parties, nor stored in any Data Processing System without the express written authorization of Michell Instruments Ltd.

---

## Contents

Safety .....	v
Electrical Safety .....	v
Pressure Safety .....	v
Toxic Materials .....	v
Repair and Maintenance .....	v
Calibration .....	v
Safety Conformity .....	v
Abbreviations .....	vi
Warnings .....	vi
<b>1 INTRODUCTION .....</b>	<b>1</b>
1.1 Features .....	1
<b>2 INSTALLATION .....</b>	<b>2</b>
2.1 Unpacking the Instrument .....	2
2.2 Electrical Schematic .....	3
2.2.1 Electrical Boundaries mA 3-Wire .....	3
2.3 Transmitter Mounting .....	4
2.3.1 Transmitter Mounting - Sample Block (Optional) .....	5
2.3.2 Transmitter Mounting - Direct Pipeline Connection .....	6
<b>3 OPERATION .....</b>	<b>7</b>
<b>4 MAINTENANCE .....</b>	<b>8</b>

## Figures

<i>Figure 1</i>	<i>SF52 .....</i>	<i>2</i>
<i>Figure 2</i>	<i>Voltage 3-Wire Connections .....</i>	<i>3</i>
<i>Figure 3</i>	<i>mA 3-Wire Connections .....</i>	<i>3</i>
<i>Figure 4</i>	<i>Maximum Load of SF52 3-Wire mA - Including Cable Resistance .....</i>	<i>3</i>
<i>Figure 5</i>	<i>Transmitter Mounting .....</i>	<i>5</i>
<i>Figure 6</i>	<i>Transmitter Mounting - Pipe or Duct .....</i>	<i>6</i>
<i>Figure 7</i>	<i>Installation Location .....</i>	<i>7</i>
<i>Figure 8</i>	<i>Indication of Dead Space .....</i>	<i>7</i>
<i>Figure 9</i>	<i>Dimensions - SF52 .....</i>	<i>11</i>
<i>Figure 10</i>	<i>Dimensions - G½" BSP Sample Block .....</i>	<i>11</i>
<i>Figure 11</i>	<i>Dimensions - G½" BSP Sample Block with Filter .....</i>	<i>11</i>

## Appendices

Appendix A	Technical Specifications .....	10
	A.1 Dimensions .....	11
Appendix B	Quality, Recycling & Warranty Information .....	13
Appendix C	Recommended Practices in Humidity Measurements .....	15
Appendix D	Return Document & Decontamination Declaration .....	20

## Safety

The manufacturer has designed this equipment to be safe when operated using the procedures detailed in this manual. The user must not use this equipment for any other purpose than that stated. Do not apply values greater than the maximum value stated.

This manual contains operating and safety instructions, which must be followed to ensure the safe operation and to maintain the equipment in a safe condition. The safety instructions are either warnings or cautions issued to protect the user and the equipment from injury or damage. Use qualified personnel and good engineering practice for all procedures in this manual.

## Electrical Safety

The instrument is designed to be completely safe when used with options and accessories supplied by the manufacturer for use with the instrument.

## Pressure Safety

DO NOT permit pressures greater than the safe working pressure to be applied to the instrument. The specified safe working pressure is up to 2 MPa, (20 barg / 290 psig)) maximum.

## Toxic Materials

The use of hazardous materials in the construction of this instrument has been minimized. During normal operation it is not possible for the user to come into contact with any hazardous substance which might be employed in the construction of the instrument. Care should, however, be exercised during maintenance and the disposal of certain parts.

## Repair and Maintenance

The instrument must be maintained either by the manufacturer or an accredited service agent. Refer to [www.michell.com](http://www.michell.com) for details of Michell Instruments' worldwide offices contact information.

## Calibration

The recommended calibration interval for this instrument is 12 months. The instrument should be returned to the manufacturer, Michell Instruments Benelux BV, for re-calibration.

## Safety Conformity

This product meets the essential protection requirements of the relevant EU directives. Further details of applied standards may be found in the product specification.

---

## Abbreviations

The following abbreviations are used in this manual:

bar	pressure unit (=100 kP or 0.987 atm)
°C	degrees Celsius
°F	degrees Fahrenheit
DC	direct current
Dp	Dew point
g	grams
g/m <sup>3</sup>	grams per cubic meter
gr/ft <sup>3</sup>	grains per cubic foot
m	meter(s)
mA	milliampere
mm	millimetres
psi	pounds per square inch
%	percentage
oz	ounces
RH	relative humidity
V	Volts
"	inches
'	feet

## Warnings

The following general warning listed below is applicable to this instrument. It is repeated in the text in the appropriate locations.



**Where this hazard warning symbol appears in the following sections it is used to indicate areas where potentially hazardous operations need to be carried out.**

## 1 INTRODUCTION

The SF52 dew-point transmitter is a simple, cost effective sensor designed for use in harsh industrial dryer applications where reliability and toughness are required at an economical cost.

The SF52 is available with a choice of G ½" and ½" NPT process connections and voltage or mA outputs. A key feature of the unit is the recessed and protected measuring element giving an extended sensor life cycle.

Michell's polymer based sensor is calibrated on a high volume traceable calibration system, providing OEM quantities of units on short deliveries, each with a 3 point calibration certificate.

### 1.1 Features

- Ideal for OEM dryer use
- Dew-point measurement range -40 to +60°C (-40 to +140°F)
- Fast response
- Rugged IP65 construction
- 3-point traceable calibration certificate
- Accuracy  $\pm 2^{\circ}\text{C}$
- Voltage or mA outputs

The SF52 is available with a voltage output (0 to 1 V, 0 to 5 V, 0 to 10 V) or a current output (4 - 20 mA 3 wire).

The current output has a 3 point diagnostic option:

Sensor fault	23 mA
Under-range dew point	4 mA
Over-range dew point	20 mA

These three values are standard factory programmed and are normally switched off.

Other diagnostic settings are available, please contact Michell Instruments for further information.

## 2 INSTALLATION

### 2.1 Unpacking the Instrument

On delivery, check that all the following standard components are in the packing box:

- SF52 transmitter
- G ½" BSP - Bonded seal fitted over threaded part of transmitter body.  
**NOTE: Not applicable to the ½" NPT**
- Certificate of calibration
- Quick Start Guide

**NOTE: If any component is not present, contact Michell Instruments immediately.**

**NOTE: Do not touch the filter disc at the front of the SF52.**



Figure 1 SF52

2.2 Electrical Schematic

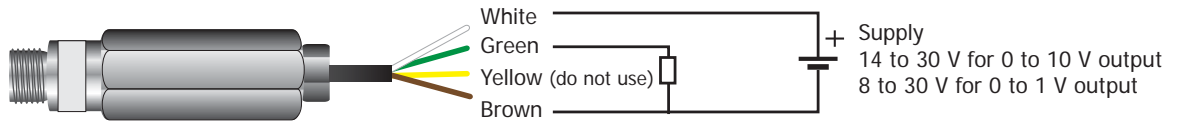

Figure 2 Voltage 3-Wire Connections

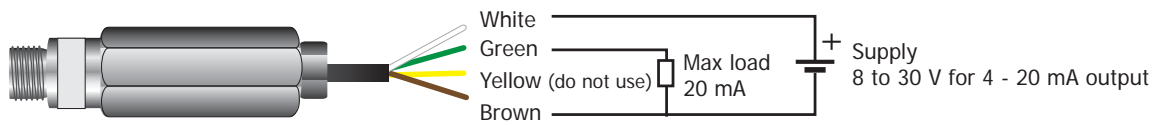

Figure 3 mA 3-Wire Connections

2.2.1 Electrical Boundaries mA 3-Wire

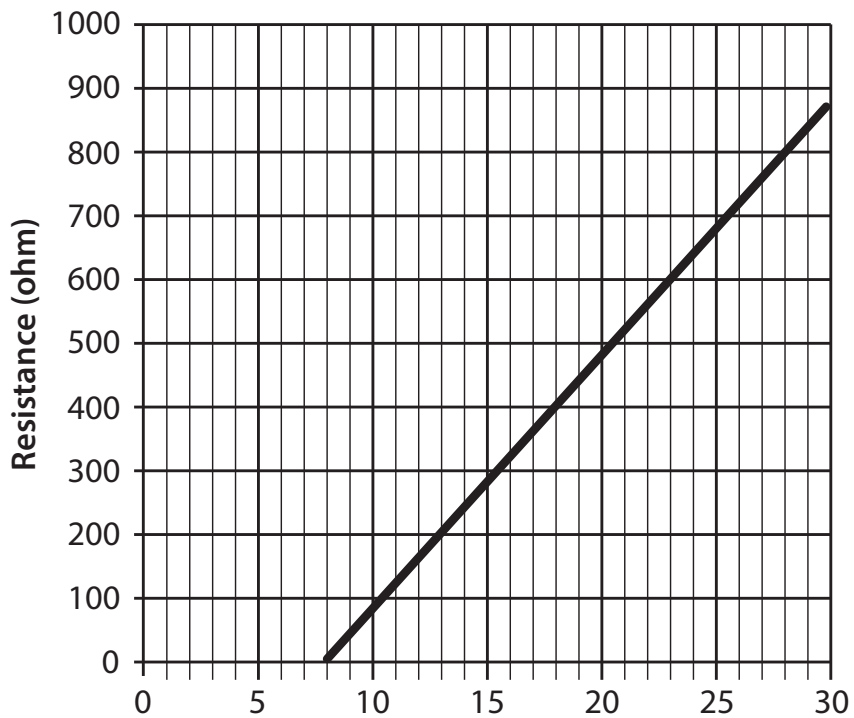

Figure 4 Maximum Load of SF52 3-Wire mA - Including Cable Resistance

### 2.3 Transmitter Mounting

Take care to prevent any contamination of the sensor before installation (**handle the transmitter by the main body only, avoiding contact with the filter disc**).

The SF52 can be mounted either into a flow-through sensor sampling block (optional) or directly into a pipe or duct. It can be operated at pressures of up to 2 MPa (20 barg / 290 psig) when fitted with the bonded seal provided.

The recommended gas flow rate, when mounted in the optional sampling block, is 1 to 5 NI/min (2.1 to 10.6 scfh). However, for direct insertion applications, gas flow can be from static to 10 m/sec (32.8 fps).

**NOTE: Pass the seal over the mounting thread and assemble into the sampling location, by hand, using the wrench flats only.**

When installed, fully tighten using a wrench until the seal is fully compressed and to the following torque settings:

- G ½" BSP                      56 Nm (41.3 ft-lbs)
- ½" NPT                         56 Nm (41.3 ft-lbs)

### 2.3.1 Transmitter Mounting - Sample Block (Optional)

(Applicable to the SF52 G ½ - BSP version ONLY)



The following procedure must be carried out by a qualified installation engineer.

To mount the transmitter into the sensor block (preferred method), proceed as follows, refer to *Figure 5*.

1. Fit the bonded seal (2) over the threaded part of the transmitter body.  
**NOTE: The bonded seal has a flat side and a rounded side. It is important that the flat side is next to the sensor steel body in order to give it the correct seal.**



Under no circumstances should the filter disc be handled with the fingers.

2. Screw the transmitter (1) into the sample block (3) and tighten to the appropriate torque setting (see Section 2.3). **NOTE: Use the flats of the hexagonal body tube and not the sensor body.**
3. Connect the SF52 TPE cable wiring connections into the electrical system.

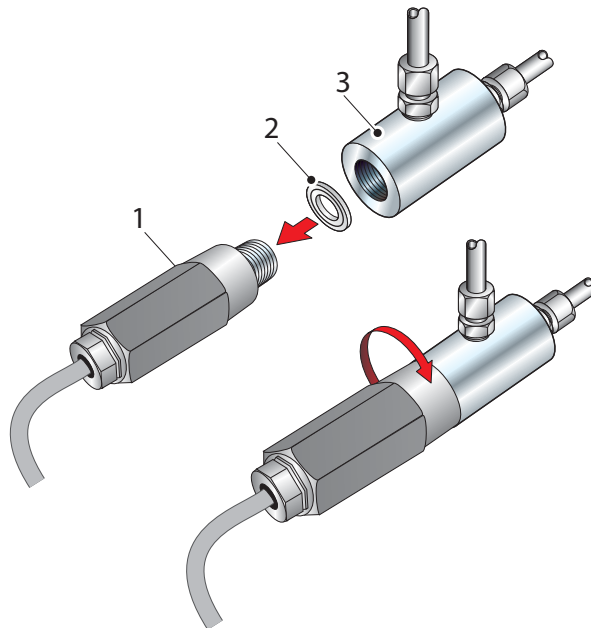

Figure 5 *Transmitter Mounting*

2.3.2 Transmitter Mounting - Direct Pipeline Connection

The transmitter may be directly mounted into a pipe or duct as shown in *Figure 6*.



**Caution: Do not mount the transmitter too close to the bottom of a bend where any condensate in the pipeline might collect and saturate the probe.**

The pipe or duct will require a thread to match the transmitter body thread. Fixing dimensions are shown in *Figure 6*. For circular pipework, to ensure the integrity of a gas tight seal, a mounting flange will be required on the pipework in order to provide a flat surface to seal against.



**The following procedure must be carried out by competent personnel.**



**WARNING: Under no circumstances should the filter disc be handled with the fingers.**

1. G ½" **ONLY** - Ensure that the bonded seal (2) is over the threaded part of the transmitter body.
2. Screw the transmitter (3) into the pipe (1). Tighten enough to obtain a gas tight seal. **NOTE: Do not overtighten or the thread on the pipework may be stripped.**

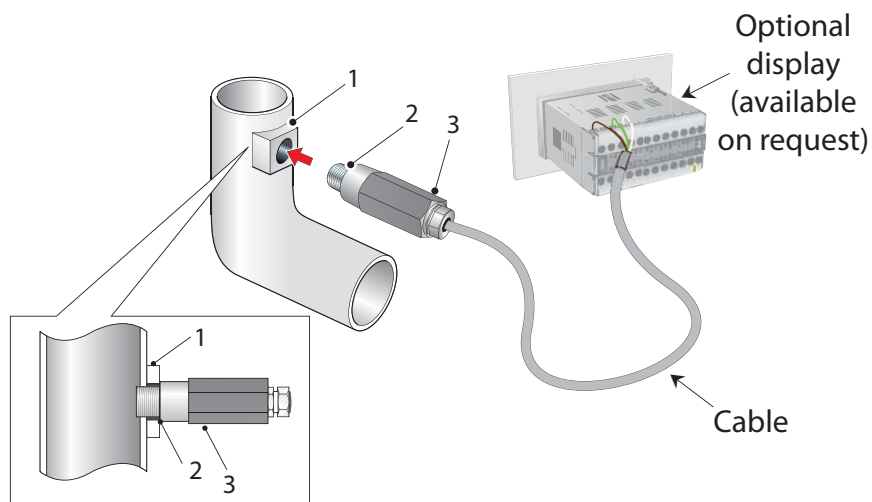

**Figure 6** Transmitter Mounting - Pipe or Duct

### 3 OPERATION

Operation is very simple, assuming the following installation techniques are adhered to:

#### Sampling Hints

##### Be Sure the Sample is Representative of the Gas Under Test:

The sample point should be as close to the critical measurement point as possible. Also, never sample from the bottom of a pipe as entrained liquids may be drawn into the sensing element.

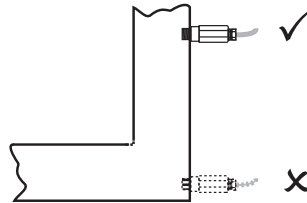

Figure 7 Installation Location

##### Minimize Dead Space in Sample Lines:

Dead space causes moisture entrapment points, increased system response times and measurement errors, as a result of the trapped moisture being released into the passing sample gas and causing an increase in partial vapor pressure.

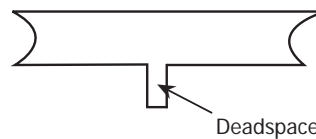

Figure 8 Indication of Dead Space

##### Remove Any Particulate Matter or Oil from the Gas Sample:

Particulate matter may 'blind' the sensing element and reduce its response speed. If particulate, such as degraded desiccant, pipe scale or rust is present in the sample gas, use an in-line filter, as a minimum level of protection. For more demanding applications Michell Instruments offers a range of sampling systems (for more information contact [www.michell.com](http://www.michell.com)).

##### Use High Quality Sample Tube and Fittings:

Michell Instruments recommends that, wherever possible, stainless steel tubing and fittings should be used. This is particularly important at low dew points since other materials have hygroscopic characteristics and adsorb moisture on the tube walls, slowing down response and, in extreme circumstances, giving false readings. For temporary applications, or where stainless steel tubing is not practical, use high quality thick walled PTFE tubing.

##### Position Transmitter away from Heat Source:

It is recommended, as good instrumentation practice, that the transmitter is placed away from any heat source to avoid adsorption/desorption.

## 4 MAINTENANCE

### Calibration

Routine maintenance of the SF52 is confined to regular re-calibration by exposure of the transmitter to sample gases of known moisture content to ensure that the stated accuracy is maintained. Calibration services traceable to the UK *National Physical Laboratory* (NPL) and the US *National Institute of Standards and Technology* (NIST) are provided by Michell Instruments.

Michell Instruments offers a variety of re-calibration schemes to suit specific needs. A Michell representative can provide detailed, custom advice (refer to [www.michell.com](http://www.michell.com) for details of Michell Instruments' worldwide offices contact information).

### Bonded Seal

If the installed bonded seal gets damaged or lost, replacement bonded seals G $\frac{1}{2}$ -BSP (order code A000340) can be obtained by contacting Michell Instruments, or your local distributor.

# Appendix A

## Technical Specifications

## Appendix A Technical Specifications

Performance									
Measurement Range	-40 to +60°Cdp (-40 to +140°Fdp)								
Accuracy	±2°Cdp (±3.6°Fdp)								
Repeatability	0.5°Cdp (0.9°Fdp)								
Stability	<1°C / year (<1.8°F / year)								
Accuracy (absolute humidity)	0.4 to 3 g/m <sup>3</sup> on value of absolute humidity								
Calibration	Traceable 3-point calibration certificate								
Electrical Specifications									
Output Signal	0 to 1, 0 to 5, 0 to 10 V or 4-20 mA (3-wire)								
Output	Dew point, absolute humidity								
Analog Output Scaled Range	Standard -40 to +60°C (-40 to +140°F) -30 to +30°C (-22 to +86°F) 0 to 200 g/m <sup>3</sup> Non-standard available upon request								
Supply Voltage	14 to 30 V DC (for 0 to 10 V output) 8 to 30 V DC (for 0 to 1 / 0 to 5 V / 4-20 mA output)								
Current Consumption	V output <9 mA mA output <29 mA								
CE Marked	Certified								
Operating Specifications									
Operating Humidity	0 - 100% RH								
Operating Temperature	-40 to +60°C (-40 to +140°F)								
Operating Pressure	2 MPa (20 barg / 290 psig) maximum								
Thermal Compensation	Characterized across operating temperature range								
Mechanical Specifications									
Ingress Protection	IP66 in accordance with standard BS EN 60529:1992 NEMA 4 in accordance with standard NEMA 250-2003								
Housing Material	Nickel-coated brass								
Dimensions	L=85mm, ø 24mm (L=3.34", ø 0.94") (max)								
Filter	HDPE front filter								
Process Connection	G ½" BSP, ½" NPT								
Weight	320g (11.29oz)								
Cable	2m (6.6') halogen free TPE cable								
Diagnostic Settings (factory programmed)	<table border="1"> <thead> <tr> <th>Condition</th> <th>Output</th> </tr> </thead> <tbody> <tr> <td>Sensor fault</td> <td>23 mA</td> </tr> <tr> <td>Under-range dew point</td> <td>4 mA</td> </tr> <tr> <td>Over-range dew point</td> <td>20 mA</td> </tr> </tbody> </table>	Condition	Output	Sensor fault	23 mA	Under-range dew point	4 mA	Over-range dew point	20 mA
Condition	Output								
Sensor fault	23 mA								
Under-range dew point	4 mA								
Over-range dew point	20 mA								

A.1 Dimensions

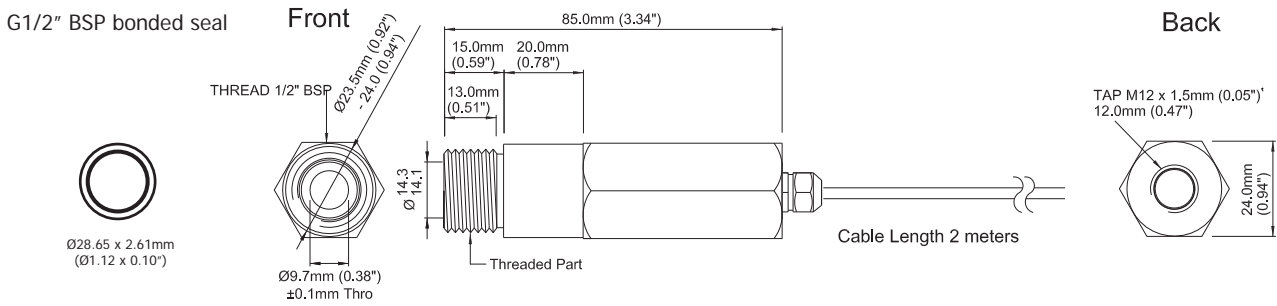

Figure 9 Dimensions - SF52

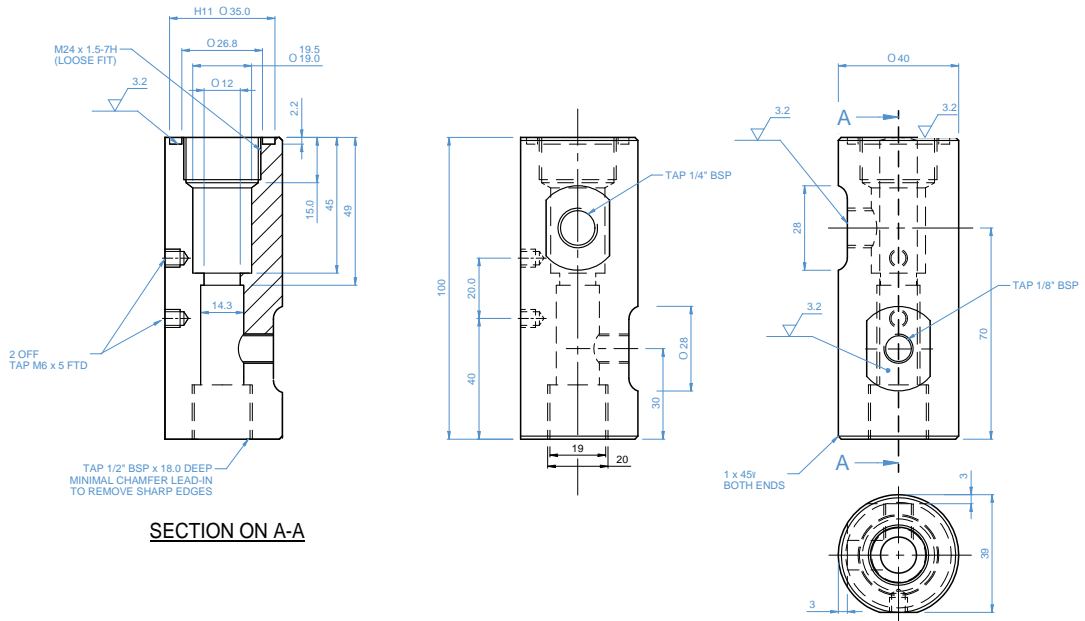

Figure 10 Dimensions - G1/2" BSP Sample Block

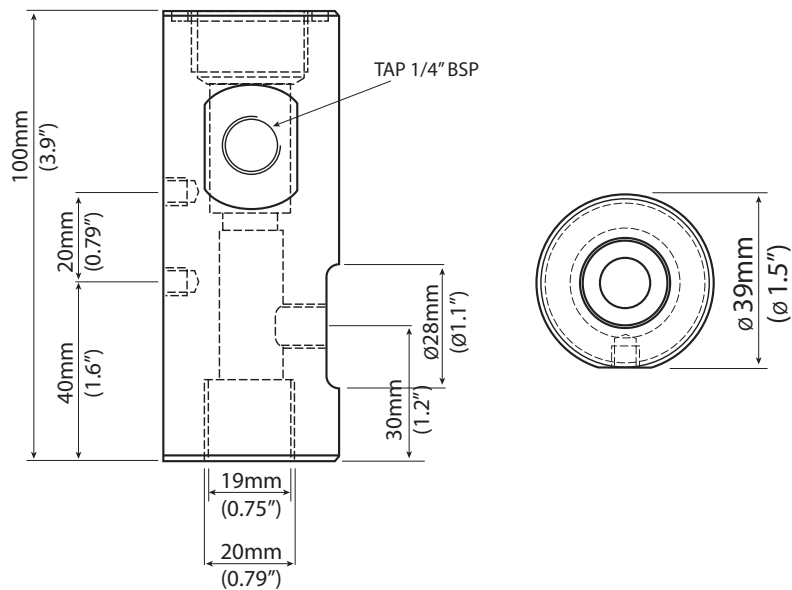

Figure 11 Dimensions - G1/2" BSP Sample Block with Filter

# Appendix B

## Quality, Recycling & Warranty Information

## Appendix B    Quality, Recycling & Warranty Information

Michell Instruments is dedicated to complying to all relevant legislation and directives. Full information can be found on our website at:

**[www.michell.com/compliance](http://www.michell.com/compliance)**

This page contains information on the following directives:

- ATEX Directive
- Calibration Facilities
- Conflict Minerals
- FCC Statement
- Manufacturing Quality
- Modern Slavery Statement
- Pressure Equipment Directive
- REACH
- RoHS2
- WEEE2
- Recycling Policy
- Warranty and Returns

This information is also available in PDF format.

# Appendix C

## Recommended Practices in Humidity Measurement

## Appendix C Recommended Practices in Humidity Measurements

The following text is reproduced with kind permission from the National Physical Laboratory. It is originally published in the booklet, *A Guide to the Measurement of Humidity*.

### Definition of Relative Humidity

**Relative Humidity** – The ratio of the actual vapor pressure to the saturation vapor pressure over a plane liquid water surface at the same temperature, expressed as a percentage. This is commonly understood when the term 'X percent relative humidity' is used.

For actual vapor pressure,  $e$ , and saturation vapor pressure,  $e_s$

$$\text{relative humidity (in \%)} = \frac{e}{e_s} \times 100$$

**USAGE:** The phrase 'relative humidity' is commonly abbreviated RH although this is not a recognized abbreviation. Values of relative humidity are commonly expressed in units of percent relative humidity (% RH).

### Recommended practices in humidity measurements

#### General practical recommendations

- Where relative humidity is of interest, a direct measurement of relative humidity is usually best. Where an absolute measure of humidity is needed, choose dew point, vapor pressure or similar measurements.
- Establish the measurement requirements at the purchasing stage in order to have the right instrument for the job.
- Allow hygrometers to equilibrate in any new environment. This is particularly necessary after changes in temperature due to transportation or storage. Depending on the instrument and on how great the change in conditions, this may require from only a few minutes to many hours.
- Follow Michell Instruments' care instructions for the instrument. Some instruments need routine cleaning or other maintenance. Before using any solvent cleaner, check with Michell Instruments that this will not harm the sensor or other materials of construction.
- Wherever possible, ensure that hygrometers are calibrated under the conditions of use, i.e. at similar values of humidity and temperature, and (if relevant) in similar conditions of pressure, airflow, etc.
- Keep a record of calibrations and any adjustments to the hygrometer. This will show the long-term stability of the instrument and allow the associated uncertainty to be assessed.
- Check instruments, if possible, at intervals between calibrations, by comparison with another (stable) instrument, to monitor for long-term drift. Routine checks are also useful before and after subjecting an instrument to transportation or other stress, which might lead to a shift in its performance. Where the check is against two (or more) instruments this is even better: not only does this add confidence, but in the event of one instrument drifting among a set of three, it can be seen which reading is most suspect.

- Cleanliness of the environment will affect different hygrometers in different ways. Dust and airborne droplets should be avoided or filtered out if possible. Contaminants can come from the most surprising sources, ordinary urban pollution, for example.
- The readings given by some types of hygrometer are sensitive to gas type. For any Instrument which reads in terms of mass per unit volume, e.g. in grams per cubic metre, it must be confirmed whether the calibration is valid for the gas in use.
- Avoid using instruments in direct sunlight or near any other source of heat, unless they are suitably shielded to prevent measurement errors.

## Sampling in general

- Relative humidity measurements should be carried out at a representative temperature. Failure to allow temperature equilibration will lead to a false indication of the relative humidity.
- Variations in vapor pressure from place to place can occur where an environment is subject to any addition or removal of water. If so, care must be taken over where to make a measurement in order to obtain a representative result.
- Sources and sinks of water vapor should be avoided in any sampling system. Invasion of stray water can be minimised by attention to leaks, hygroscopic materials, droplets and condensation. The lower the humidity, the more critical these precautions are.
- Hygroscopic materials should be avoided. Many materials contain moisture as part of their structure, particularly organic materials (whether natural or synthetic), salts (or anything which contains them), and anything which has small pores. Temperature changes can increase the tendency of these materials to affect the humidity of the surrounding air.
- Condensation in a sampling process can invalidate humidity measurements by reducing the water content of the gas being measured. What is more, condensed liquid may alter the humidity elsewhere by dripping or running to other locations and evaporating there. In these circumstances, measurement results may be misleading if hygrometer location is not considered carefully.
- Water droplets or mist must be avoided. These can result in overestimates of the humidity of the air between the droplets. Such results may exceed 100% RH, or may be impossible to interpret meaningfully. Droplets of liquid also damage some electrical types of humidity sensor. Filtering the air sample can eliminate droplets.
- If pumps are used for sampling gas, these should be located after the hygrometer, to avoid contaminating the measurement environment. Where possible, oil free pumps should be used, or filters employed. Oscillations in pressure due to pumping can sometimes be reduced or buffered using a needle valve or a reservoir of large volume.
- Special treatments such as filtration can change the amount of moisture in a gas. Some drying agents take out other gases too.
- When sealing any sensor or probe into a port or manifold in a duct or chamber, leaks through the probe or electrical cable should be considered. These are not always sealed against passage of ambient air.
- Where sampling involves a step change in temperature, pressure or gas flow rate, relative to the process being sampled, results may need to be converted or interpreted. For example 'pressure dew point' will differ from the value found after expanding the gas sample to atmospheric pressure. Care should be taken to distinguish between 'gauge' and absolute values of pressure.

## Dew point in general

- The measuring environment and all parts of the sampling pathway must be kept above the dew point if condensation is to be avoided. Electrical trace heating or other heating methods should be used if necessary. An excess temperature of 10°C above the dew point is usually a safe margin.
- For measurements in the region below 0°C it must be clear whether the condensate is dew or frost. Failure to distinguish between these can result in errors of about 1°C for every 10°C below zero.

## Relative humidity in general

- Due care must be taken of temperature. The effect of temperature on humidity is highly significant. Failure to take this into account can sometimes lead to errors so large that the measurement is meaningless. In many situations, the largest single source of uncertainty in a humidity measurement is the effect of temperature differences from place to place in the process, room or chamber. The importance of considering the temperature effects carefully cannot be overstated when relative humidity is the parameter of interest.
- Care must be taken when expressing uncertainties, changes or fractional differences in relative humidity. For example, the difference between 50% RH and 52% RH is 2% RH. This can also be expressed as a difference of 4% of value. It is important to distinguish clearly between these two kinds of statement.

## Recommendations specific to ranges of measurements

- Ambient humidity - Avoid using hygrometers near the body, which is a source of heat and moisture. Do not breathe close to the measurement.
- High humidity, above the ambient range - Ample lines should be maintained above the dew point of the gas being measured, to avoid condensation. Electrical trace heating is often the most practical method.
- Low humidity, and very dry gases - If possible, prepare for measurements by flushing sample lines and hygrometers with dry gas, or by evacuating to low pressure. Drive off stray residual water by baking assemblies if possible (but not instruments – unless designed for this!). The lower the moisture content to be measured, the more dramatically the required drying time multiplies.
- Avoid hygroscopic materials. At low humidity (anything much below a dew point of 0°C) the amounts of water given off by organic and porous materials can dramatically affect the value of humidity. The lower the level of moisture, the more significant the effects.
- Choose impermeable materials, to avoid inward diffusion of moisture through sampling tubes and enclosures. Steel and other metals are practically impermeable. PTFE ('Teflon') is only slightly permeable and will usually be satisfactory for dew points above -20°C, and sometimes below this level. Materials such as PVC and rubber are relatively permeable and so totally unsuitable at low humidity, and not really satisfactory in any humidity range.
- Surface finish of pipework is important for very dry gases. Even the tiny quantities of water adsorbed on the surfaces of non-hygroscopic materials can have significant effect. Polished or electropolished steel is recommended for the best results.

- Clean environments are always best for humidity measurements, but this is especially critical at very low humidity. Even fingerprints harbour water. High purity cleaning agents are recommended: Analytical Reagent (AR) quality solvents for oil-based contaminants, and purified water (distilled or de-ionised) for salts. Cleaning should be followed by thorough drying by a clean method.
- Sample tubing should be as short in length as possible. The surface area should be minimised by using the narrowest tubing that the flow conditions will permit.
- Avoid leaks. Minimising the number of connections (elbows, tees, valves, etc.) helps with this.
- Adequate flow of the gas sample should be ensured, to minimise the influence of sources of stray water in the flow path.
- 'Dead ends' should be avoided, as they cannot easily be flushed.
- Back-diffusion of moisture should be minimised, e.g. by fast flow rates of gas, long exhaust tubes after the sensor, or by valves which isolate the low-humidity region from ambient air.

## Practical recommendations for specific types of hygrometer

### Relative humidity capacitive sensor

- Care should be taken to avoid mechanical shock (impact) or thermal shock (sudden temperature changes). Sensors should be protected from steam or water sprays, and from direct sunlight.
- Where a sensor is at risk of exposure to dust, droplets, or the occasional knock during handling, the appropriate guard or filters for the sensor head should be used.
- Any temptation to breathe on the sensor, or to wave it over cups of tea, etc. should be resisted. Filters and saturation guarding may protect the sensor, but these actions carry a risk of damage by condensation or other contamination.
- Protective filters can slow the response time of sensors. This can be avoided by removing any filter, but the benefit must be weighed against the risk of damage to the sensor.
- Sensors should not normally be submerged in liquids. In the case of a resistive (electrolytic) sensor, water or other liquids would certainly damage the sensor beyond repair.
- Salt solutions are especially commonly used for calibration of electrical sensors, and should be provided with traceability directly or via a calibrated hygrometer. Protection of sensors from direct contact with salt or solution is most important as contamination would destroy or seriously impair the sensing element.

# Appendix D

## Return Document & Decontamination Declaration

## Appendix D Return Document &amp; Decontamination Declaration

## Decontamination Certificate

**IMPORTANT NOTE:** Please complete this form prior to this instrument, or any components, leaving your site and being returned to us, or, where applicable, prior to any work being carried out by a Michell engineer at your site.

Instrument			Serial Number	
Warranty Repair?	YES	NO	Original PO #	
Company Name			Contact Name	
Address				
Telephone #		E-mail address		
Reason for Return /Description of Fault:				
Has this equipment been exposed (internally or externally) to any of the following? Please circle (YES/NO) as applicable and provide details below				
Biohazards	YES		NO	
Biological agents	YES		NO	
Hazardous chemicals	YES		NO	
Radioactive substances	YES		NO	
Other hazards	YES		NO	
Please provide details of any hazardous materials used with this equipment as indicated above (use continuation sheet if necessary)				
Your method of cleaning/decontamination				
Has the equipment been cleaned and decontaminated?	YES		NOT NECESSARY	
Michell Instruments will not accept instruments that have been exposed to toxins, radio-activity or bio-hazardous materials. For most applications involving solvents, acidic, basic, flammable or toxic gases a simple purge with dry gas (dew point <-30°C) over 24 hours should be sufficient to decontaminate the unit prior to return. <b>Work will not be carried out on any unit that does not have a completed decontamination declaration.</b>				
<b>Decontamination Declaration</b>				
I declare that the information above is true and complete to the best of my knowledge, and it is safe for Michell personnel to service or repair the returned instrument.				
Name (Print)			Position	
Signature			Date	



F0121, Issue 2, December 2011

Manufacturer: **Michell Instruments B.V.**  
**Krombraak 11**  
**4906 CR Oosterhout**  
**The Netherlands.**



We declare under our sole responsibility that the product:

## **SF52 Dewpoint Transmitter**

complies with all the essential requirements of the EU directives listed below.

**2014/30/EU**      **EMC Directive**

**2011/65/EU**      **Restriction of Hazardous Substances Directive (RoHS2)**

Using the standards:

**EN61326-1:2013**      Electrical equipment for measurement, control and laboratory use – EMC requirements – Group 1, Class B (emissions) and immunity.

and has been designed to be in conformance with the relevant sections of the following standards or other normative documents.

**EN61010-1:2010**      Safety Requirements for Electrical Equipment for Measurement, Control, and Laboratory Use Part 1: General Requirements

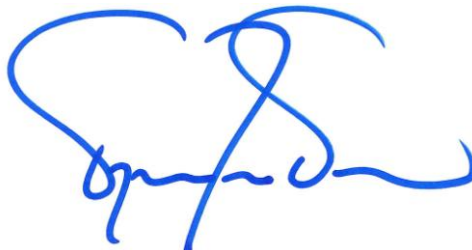

Robert-Jan Pouw RH Business Manager.  
Michell Instruments Benelux B.V. Oosterhout The Netherlands  
Date of Issue 6 December 2017

---

on behalf of  
Peter Haakma Managing Director Michell Instruments Benelux B.V.



Instrument Expert  
Original factory  
packaging  
[www.keruiyiqi.cn](http://www.keruiyiqi.cn)



<http://www.michell.com>