



XTC601

Binary Gas Analyzer

User Manual



Please fill out the form(s) below for each instrument that has been purchased.

Use this information when contacting Michell Instruments for service purposes.

Product Name	
Order Code	
Serial Number	
Invoice Date	
Installation Location	
Tag Number	

Product Name	
Order Code	
Serial Number	
Invoice Date	
Installation Location	
Tag Number	

Product Name	
Order Code	
Serial Number	
Invoice Date	
Installation Location	
Tag Number	



XTC601

For Michell Instruments' contact information please go to
www.michell.com

© 2021 Michell Instruments

This document is the property of Michell Instruments Ltd and may not be copied or otherwise reproduced, communicated in any way to third parties, nor stored in any Data Processing System without the express written authorization of Michell Instruments Ltd.

Contents

Safety	vii
Electrical Safety	vii
Hazardous Area Safety	viii
Pressure Safety	ix
Temperature Safety	ix
Toxic Materials	ix
Repair and Maintenance	x
Calibration	x
Safety Conformity	x
Abbreviations.....	x
1 INTRODUCTION	1
1.1 Features	2
1.2 Applications	3
1.3 O-Ring Selection.....	3
2 OPERATION	4
2.1 Preparation	4
2.2 Powering up the Analyzer.....	5
2.3 User Interface	6
2.3.1 Interface Controls	6
2.3.2 'ESC' Button.....	7
2.3.3 'Up/Down Arrow' Buttons.....	7
2.3.4 'ENTER' Button	7
2.4 Menu Structure	8
2.4.1 Changing the Passcode.....	8
2.4.2 Menu Map	9
2.5 Front Pages (No Passcode Required).....	11
2.5.1 Main Page	11
2.5.2 Chart Page	12
2.5.3 Secondary Parameters Page.....	13
2.5.4 Target Gas Min/Max Page	14
2.5.5 Alarms Log Pages	14
2.6 Info Page	15
2.7 User Set-Up Variables (Passcode Required)	16
2.7.1 Settings Page.....	17
2.7.2 Human Machine Interface (HMI) Page	18
2.7.3 Reset Page	20
2.7.4 Alarms Page	21
2.7.5 Alarm page (HCG version only)	22
2.7.6 External Compensation Page (standard version only).....	23
2.7.7 Phase Page (HCG version only)	24
2.7.8 External Sensor Page	25
2.7.9 Outputs Page.....	26
2.7.10 Field Cal Page.....	28
2.7.11 Status LED or Light Guide.....	29
3 CALIBRATION.....	30
3.1 Factory Calibration.....	30
3.2 Field Calibration	30
3.3 Before Calibration.....	30
3.4 Calibration Pressure / Flow Rate	31
3.5 1-Point Calibration	31

3.6	2-Point Calibration	32
3.7	Field Calibration Reset	33
4	INSTALLATION	34
4.1	Unpacking.....	34
4.2	System Components	35
4.3	Set-Up.....	36
4.4	Mechanical Installation.....	37
4.4.1	Gas Connection Tape.....	37
4.4.2	Sample Gas Requirements	38
4.4.3	Calibration Gases	38
4.5	Electrical Installation.....	39
4.5.1	Power Supply and Input/Output Signal	39
4.5.2	Power Supply	39
4.5.3	Analog Output	39
4.5.4	Serial Output	40
4.5.5	Analog (4...20 mA) Outputs and Communications.....	40
4.5.6	Alarm Relay Contacts	40
4.5.7	Analog (4...20mA) Inputs and Sensor Excitation Voltage	41
4.5.8	Light Guide.....	41

Appendices

Appendix A	Technical Specifications.....	43
	A.1 Standard XTC601.....	43
	A.2 XTC601 for Monitoring Hydrogen Cooled Generators	45
Appendix B	Dimensional Drawings.....	47
Appendix C	Thermal Conductivity Table	49
Appendix D	Modbus Register Map (standard version).....	51
Appendix E	Modbus Register Map (HCG version)	57
Appendix F	Hazardous Area Certification	64
	F.1 Product Standards	64
	F.2 Product Standards	64
	F.3 Global Certificates/Approvals	64
	F.4 Special Conditions.....	65
	F.5 Maintenance and Installation	65
Appendix G	Quality, Recycling, Compliance & Warranty Information.....	67
Appendix H	Analyzer Return Document & Decontamination Declaration	69

Figures

Figure 1	XTC601 Binary Gas Analyzer Versions	1
Figure 2	Initializing Screen	5
Figure 3	Main Page.....	5
Figure 4	User Interface.....	6
Figure 5	XTC601 Application Software.....	6
Figure 6	ESC Button	7
Figure 7	Up/Down Arrow Buttons	7
Figure 8	ENTER Button	7
Figure 9	Menu Map – Standard XTC601	9
Figure 10	Menu Map – HCG version	10
Figure 11	Main page display.....	11
Figure 12	Chart page.....	12
Figure 13	Secondary parameters page.....	13
Figure 14	Target gas min/max page.....	14
Figure 15	Alarms log page	14
Figure 16	Info page.....	15
Figure 17	User menu (Standard version).....	16
Figure 18	User menu (HCG version)	16
Figure 19	Settings page (Standard version only).....	17
Figure 20	HMI page.....	18
Figure 21	Date and Time Page	19
Figure 22	Reset page.....	20
Figure 23	Alarm page	21
Figure 24	Alarm page (HCG version only).....	22
Figure 25	External Compensation page	23
Figure 26	Phase page.....	24
Figure 27	External sensor page	25
Figure 28	Outputs page	26
Figure 29	NAMUR ERR Page.....	27
Figure 30	Field Cal page	28
Figure 31	1-Point Calibration Page.....	31
Figure 32	2-Point Calibration Page.....	32
Figure 33	Reset page.....	33
Figure 34	XTC601 Showing Major Components.....	35
Figure 35	XTC601 Lid Removal.....	36
Figure 36	XTC601 Gas Connections and Cable Entries.....	37
Figure 37	Terminal Block Locations.....	39
Figure 38	Dimensional Drawings.....	47

Safety

The manufacturer has designed this equipment to be safe when operated using the procedures detailed in this manual. The user must not use this equipment for any other purpose than that stated. Do not apply values greater than the maximum value stated.

This manual contains operating and safety instructions, which must be followed to ensure the safe operation and to maintain the equipment in a safe condition. The safety instructions are either warnings or cautions issued to protect the user and the equipment from injury or damage. Use qualified personnel and good engineering practice for all procedures in this manual.



Where this symbol appears in the following sections it is used to indicate areas where potentially hazardous operations need to be carried out and where particular attention to personal and personnel safety must be observed.

Electrical Safety



WARNING:
During the installation of this product ensure that all applicable national and local electrical safety regulations are observed.



WARNING:
Isolate the power prior to installation.



WARNING:
Always ensure that power is switched off prior to accessing the product for any purpose other than normal operation or prior to disconnecting any cables.

In compliance with IEC 61010 Electrical Safety Standard the following applies to this product:

Equipment ratings:

This equipment must be supplied with a voltage of 24 V DC, 1.5 A (36 W).

The power is connected via PL9 on the mother board (see Section 4.5).

All input and output connectors are 2-part pcb mounted type.

The detachable, screw terminal half of each connector is designed to accept 24–12 AWG stranded or solid conductors.

Ensure suitably rated power supply cables and glands are used to ensure that electrical safety is maintained. Connect to the POWER IN each of the Live (L), Neutral (N) and Earth [Ground] (E) conductors to the similarly marked terminals (L, N, E). Ensure the power supply can deliver sufficient power consumption requirement.

Ensure any power supply terminals and voltages are suitably separated from the other I/O requirements of this product.

Before applying power, perform a continuity test to ensure that the power supply cable and product are effectively connected to the protective Earth.

The product enclosure is supplied with an external Earth stud at the lower right hand side. At installation, connect this Earth stud to plant Earth by a minimum 4mm² earthing bonding.

Fuse – A replacement fuse can be obtained by contacting Michell Instruments' technical support. Michell order number – XTC601-26149.

This product is designed to operate, as a minimum, between a temperature range of -5...+40 °C (+23...+104 °F), in maximum 80% relative humidity for temperatures up to +31 °C (+87 °F) decreasing linearly to 50 %rh at 50 °C (122 °F). Supply voltages of ±10% and transient over voltages up to Overvoltage Category II. Pollution Degree 2. Altitudes up to 2,000 meters. Outdoor mounting is permitted using suitably rated glands equivalent to NEMA 4 / IP66. See Technical Specifications (Appendix A) in this manual for full operating parameters. Do not remove or exchange any of the cables or electrical components supplied with this product. To do so will invalidate all warranties. There are no additional or special electrical safety requirements other than those referred to in this manual.

Location and mounting arrangements. Refer to the relevant sections of this manual for the location and mounting details.

Installation of this equipment should include the provision of a suitable and locally positioned power isolation switch or circuit breaker.

Ensure this equipment and all power isolation devices are installed in a location and position that allows safe and easy access to their operation and is adequate to rigidly support the equipment.

Do not install this equipment in a location that would expose it to impact or high levels of vibration.

Operation of this equipment, other than in a manner as specified by the manufacturer, may impair the safety protections provided.

The safe installation of this equipment and any system incorporating this equipment is the responsibility of the installer. Ensure local regulations and requirements are referred to prior to any installation commencing.

Hazardous Area Safety

Appendix F of this manual refers to the EX version and the Hazardous Area Certification of this product.

This product is fitted with a marking label that contains Hazardous Area information pertinent to the suitable location and installation.

During all installation and operation activities local regulations and permitted working routines must be observed. Installation should only be performed by competent personnel and in accordance with IEC/EN 60079-14:2008 or local equivalent.

Repair and servicing of this equipment must only be carried out by the manufacturer.



WARNING:
This product is certified safe for use in a Zone 1 and Zone 2 area only. This product must not be installed or used within a Zone 0 area.



WARNING:
This product must not be operated within an explosive atmosphere greater than 1.1 bar absolute.



WARNING:
This product must not be operated outside of the temperature range of -40...+55 °C (-40...+131 °F).

Pressure Safety



WARNING:
This product is used in conjunction with pressurized gases. Observe pressurized gas handling precautions.



WARNING:
Pressurized gas is dangerous. Pressurized gas should only be handled by suitably trained personnel.

The XTC601 measurement chamber requires pressurized gas to be connected to it. Observe pressurized gas handling regulations. Suitably trained personnel only should carry out tasks that include the use of pressurized gas mediums.

DO NOT permit pressures greater than the safe working pressure to be applied to the instrument. The specified safe working pressure for this instrument is 1 barg (14.5 psig) max.

Temperature Safety

During operation some internal parts of the instrument may be at high temperature.

Toxic Materials

The use of hazardous materials in the construction of this instrument has been minimized. During normal operation it is not possible for the user to come into contact with any hazardous substance which might be employed in the construction of the instrument. Care should, however, be exercised during maintenance and the disposal of certain parts.

Long exposure to, or breathing of the calibration gases, may be dangerous.

Repair and Maintenance

The instrument must be maintained either by the manufacturer or an accredited service agent. For Michell Instruments' worldwide offices contact information go to www.michell.com.

Calibration

The recommended calibration interval for the analyzer is 1 month.

Safety Conformity

This product carries the CE/UKCA mark and meets the requirements of relevant European safety directives.

Abbreviations

The following abbreviations are used in this manual:

A	Ampere
AC	alternating current
bara	pressure in bar (absolute)
barg	pressure in bar (gauge)
°C	degrees Celsius
°F	degrees Fahrenheit
DC	direct current
kg	kilogram
kPa	Kilopascal
lb	pound
max	maximum
mA	milliampere
ml/min	milliliters per minute
mm	millimeters
µm	micrometer
ppm	parts per million
psig	pounds per square inch
scfh	standard cubic feet per hour
V	Volt
"	inches
Ω	ohm
%	percentage

1 INTRODUCTION

This manual will show how to measure binary or pseudo-binary gases easily using the XTC601 Binary Gas Analyzer.

The following sections contain information about:

- Analyzer components
- Operating instructions
- Calibration and maintenance of the analyzer
- Installation

Please read this manual carefully and pay special attention to the safety warnings and notifications.

NOTE: Warnings and important notifications are marked with bold text.

The different versions of the XTC601 available are shown below:



Figure 1 XTC601 Binary Gas Analyzer Versions

The XTC601 Binary Gas Analyzer is based on Michell Instruments' advanced proprietary technology. It measures the percentage levels of a Target Gas in a selection of background gases, including nitrogen, hydrogen, carbon dioxide, methane and biogas. The sensor is housed in a weather-proof (GP version) or explosion-proof (EX version) casing – both IP66 & NEMA 4 rated. It is suitable for a range of applications in safe or hazardous areas. The GP2 version is for use with flammable gases in a safe area.

The XTC601 is available in single phase configuration for measurement of a variety of binary gases, or in three phase 'HCG' configuration for hydrogen cooled generator applications only.

NOTE: This manual is intended for use with analyzers with the following firmware Versions:

Standard Model: V1.08
HCG Model: V1.06

1.1 Features

- The XTC601 standard analyzer can now be supplied to meet the requirements of IEC 61508 SIL 2. This will allow the user to integrate the unit in a functional safety system.
- The robust and weather-proof enclosure (IP66 rated) allows the XTC601 to be installed on-site, at the point of measurement. The EX version is housed in an explosion-proof casing, and is certified to II 2GD Ex d IIB+H2 T6 Gb, Ex tb IIIC T85 °C Db IP66 Tamb -40 °C...+55 °C.
- The XTC601 provides 2 off 4...20 mA analog output signals that are proportional to the Target Gas concentration. The primary 4...20 mA output is locked on the calibrated range of the instrument. The secondary output on the standard instrument is user-selectable within the calibrated range. On the HCG version this output indicates the selected phase:

1. Phase 1 = 7 mA...9 mA

2. Phase 2 = 11 mA...13 mA

3. Phase 3 = 15 mA...17 mA

- Modbus RTU over RS485 serial communications are provided as standard.
- The XTC601 HCG measurement phase can be changed via the HMI, a Modbus RTU register or by 4...20 mA input signal.
- Accuracy of 2% of span for standard ranges.
- Zero and span stability of 0.5% of span per month.
- The sensor used in the XTC601 Binary Gas Analyzer has no moving parts. This reduces sensitivity to vibration and movement.
- All of the analyzer functions can be accessed via the touch screen (capacitive) buttons or via the Application Software.
- Low cost of ownership due to minimal maintenance.
- When required, the casing unscrews to allow for easy access to the sensor, enabling maintenance to be carried out quickly and easily.
- The XTC601 is certified to ATEX, IECEx, UKCA & cQPSus for use in hazardous areas.
- 2 x single pole change-over relay alarms for Target Gas concentration, supplied as standard.

1.2 Applications

The XTC601 binary gas analyzer is designed for use in process environments.

A sample system may be required to ensure that a clean, dry gas with no particles or oil-mist is delivered to the XTC601. This will ensure the sensor is not damaged or contaminated by the process. Michell Instruments is able to supply a quotation for such a system.

Examples of applications include:

- H₂ generator cooling systems (Power Generation)
- H₂ in heat treatment furnaces (Metals)
- CO₂ in fermentation process (Food)
- CO₂ in biogas
- Ethylene Oxide sterilization process (Food)
- H₂ in blast furnace top gas (Steel)
- H₂ in hydrocarbons (Petrochemical)
- He recovery (Industrial Gas)

1.3 O-Ring Selection

The XTC601 has only one elastomeric seal in the gas path. There are 3 types of O-rings available to offer greater flexibility with material compatibility. The Viton O-ring is fitted as standard. The Ekraz O-ring is available for solvent resistance. For extremely low temperatures there is a closed cell Silicone O-ring.

To comply with Hazardous Area certification, the material used in the EX1 version is dependent on the lowest ambient temperature of the area the units are to be installed in:

Ambient temperature range for transport and storage:

-40 °C...+60 °C (-40 °F...+140 °F) (for Silicone O-ring)

-15 °C...+60 °C (+5 °F...+140 °F) (for Viton O-ring) – Standard

-10 °C...+60 °C (+14 °F...+140 °F) (for Ekraz O-ring)

NOTE: The silicone O-ring cannot be selected for samples containing > 21% O₂.

2 OPERATION



The XTC601 is not certified for use with ambient oxygen levels that are enriched (i.e. over 21 % O₂)

This analyzer has been manufactured within our quality procedures and is configured according to the purchase order. When it is installed and used as per the manufacturer's guidelines, it will operate within the stated specification.

Before starting operation it is recommended that the user becomes familiar with this manual in which all the equipment controls, indicators, the elements of the display and the overall menu structure are described.

2.1 Preparation



Before applying power and beginning the flow of gas, please ensure that the system has been properly installed following the instructions in Section 4.

Check that the wiring has been completed correctly.

Zero and Span gas cylinders with correct regulation and flow control should be in place before installing and powering up the analyzer. Commissioning should include a check with both gases and, if necessary, a field calibration performed.

All analyzers are factory calibrated using Mass Flow Controllers with an inlet pressure of 1 barg (14.5 psig) and the flow through the unit is set to 300 ml/min (0.63 scfh) with an atmospheric vent. During commissioning or routine field adjustment, the calibration gas applied to the analyzer should be at the same pressure and flow rate as the process gas to be sampled.

Note: unless specifically factory calibrated otherwise, this analyzer should be operated at atmospheric pressure.

General Purpose units:

- Sample Inlet Pressure: Constant from 0 to 0.5 barg (0...7 psig)
- Sample Flow Rate: Stable from 100 to 500 ml/min (0.25...1.0 scfh)

Ex or GP units with flame arrestors:

- Sample Inlet Pressure: 50...350 mbarg (0.5...5 psig)
- Sample Flow Rate: 270...330 ml/min (0.57...0.7 scfh)

2.2 Powering up the Analyzer



After all the preparation work has been done and the installation and wiring have been checked, turn on the analyzer and wait for at least 30 minutes (or until Cell T Not Stable message disappears). This will allow the analyzer to reach its operating temperature of +50 °C (122 °F) and protect it from any condensation forming in the sensor.

There is no power switch on the XTC601 Binary Gas Analyzer. It is turned on automatically once a 24 V DC power source is applied. After the analyzer is powered up, the display will be illuminated. The analyzer takes up to 5 seconds to initialize, and during this period will display the product type and firmware version number.

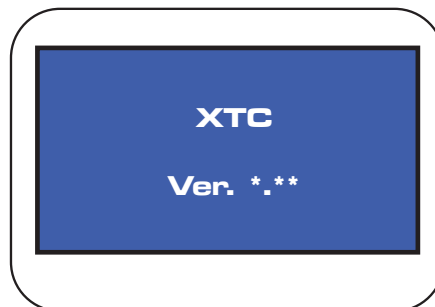

Figure 2 *Initializing Screen*

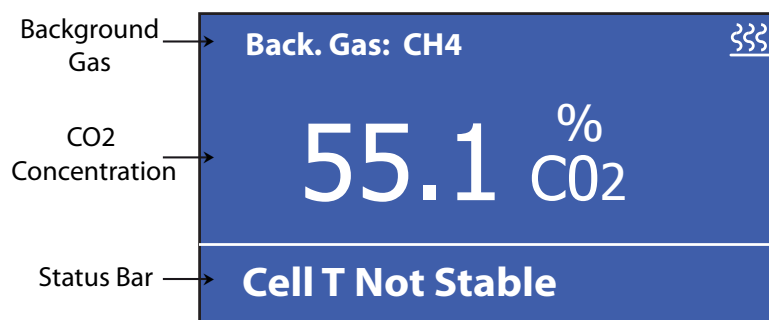

Figure 3 *Main Page*

Once initialized, the analyzer will show the Main Page which displays the Target Gas concentration and the background gas that the unit has been calibrated in.

During warm-up (less than 25 minutes) a heating symbol will flash in the top right hand corner of the page. This symbol will remain for a minimum of 5 minutes until the temperature has stabilized. The analyzer will be ready for use within 30 minutes from power-up.

2.3 User Interface

2.3.1 Interface Controls

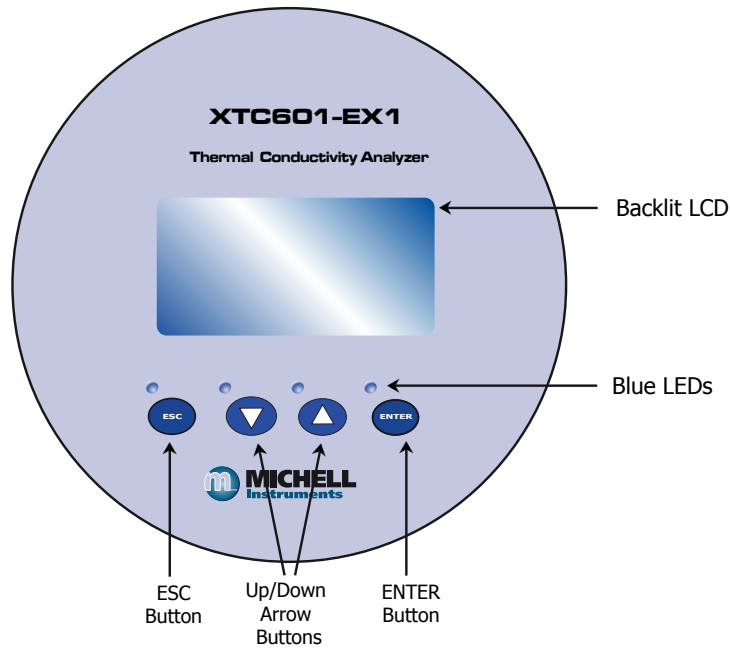

Figure 4 User Interface

The diagram above illustrates the user interface, which consists of a backlit Liquid Crystal Display and 4 touch-sensitive pads that facilitate user interaction through the glass of the enclosure.

All versions have Application Software to monitor or adjust parameters.

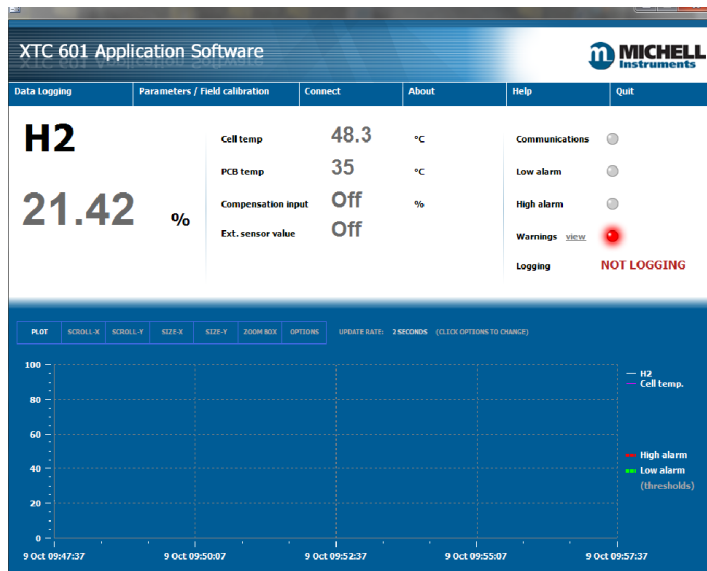

Figure 5 XTC601 Application Software

2.3.2 'ESC' Button



Figure 6 *ESC Button*

The **ESC** button is used to exit the current menu and to return to the previous menu.

From the Main Page, pressing **ESC** will access the Info Page.

2.3.3 'Up/Down Arrow' Buttons

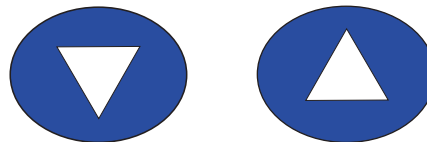

Figure 7 *Up/Down Arrow Buttons*

The **Up** (▲) and **Down** (▼) buttons are used to change pages, scroll through lists and adjust values.

In the Reset and Field Calibration Menus, pressing the **Up** (▲) button 3 times will confirm a selection.

2.3.4 'ENTER' Button



Figure 8 *ENTER Button*

The **ENTER** button is used to select or de-select the highlighted item in a menu and to confirm a value.

From the Main Page, pressing **ENTER** will access the Passcode Page.

2.4 Menu Structure

The XTC601 front pages allow the user to scroll through and view Target Gas concentration, recent trend, internal parameters, minimum & maximum concentration and alarm history.

In order to change any settings on the User Menu pages, the user must enter a passcode. There is also a separate passcode for service engineers to allow factory setting changes.

To access the User Menu press the **ENTER** button from the Main Page to call up a passcode prompt. Use the **Up (▲)** and **Down (▼)** buttons and press **ENTER** after each value.

The User Passcode is: 1919

From the Main Page the user can press the **ESC** button to view the Info Page. This page shows the firmware version, hours used, last calibration date, calibration pressure and the received Modbus code.

The passcode is stored for one minute to allow access back into the User Menu, if necessary.

2.4.1 Changing the Passcode

As part of the SIL compliance the user must change the passcode after the unit is set up and before bringing it on-line in a functional safety system. This new passcode must be kept secure and must only be made available to authorized personnel.

Press **Enter** from the Front Page and arrive at the Passcode Screen.

Enter the activation code: 6182 and the unit will be ready to accept the new passcode.

Warning: The passcode can only be changed once, so care must be taken from this point onwards.

Now enter the new passcode and once activated the analyzer will bring you straight into the user menu. If you want to change your mind or you make a mistake at any point before you hit the enter button the final time, just press and hold the **ESC** button to return to the front screen and start again.

The passcode will be active for 5 minutes, so make a note of what was actually entered by going back to the passcode screen. Store this new passcode in a secure place.

If you forget/lose the passcode, contact Michell Instruments for help.

2.4.2 Menu Map

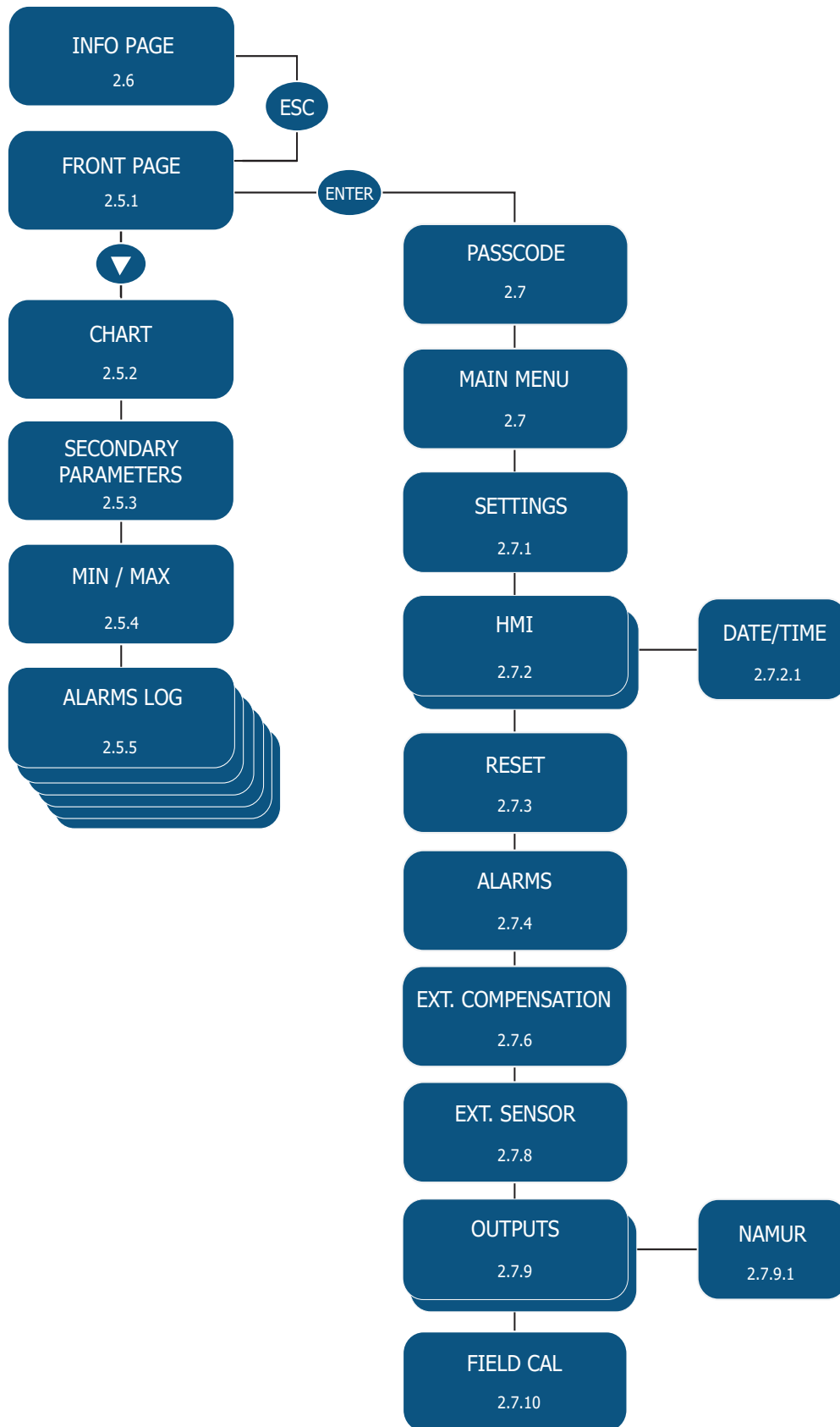

Figure 9 Menu Map – Standard XTC601

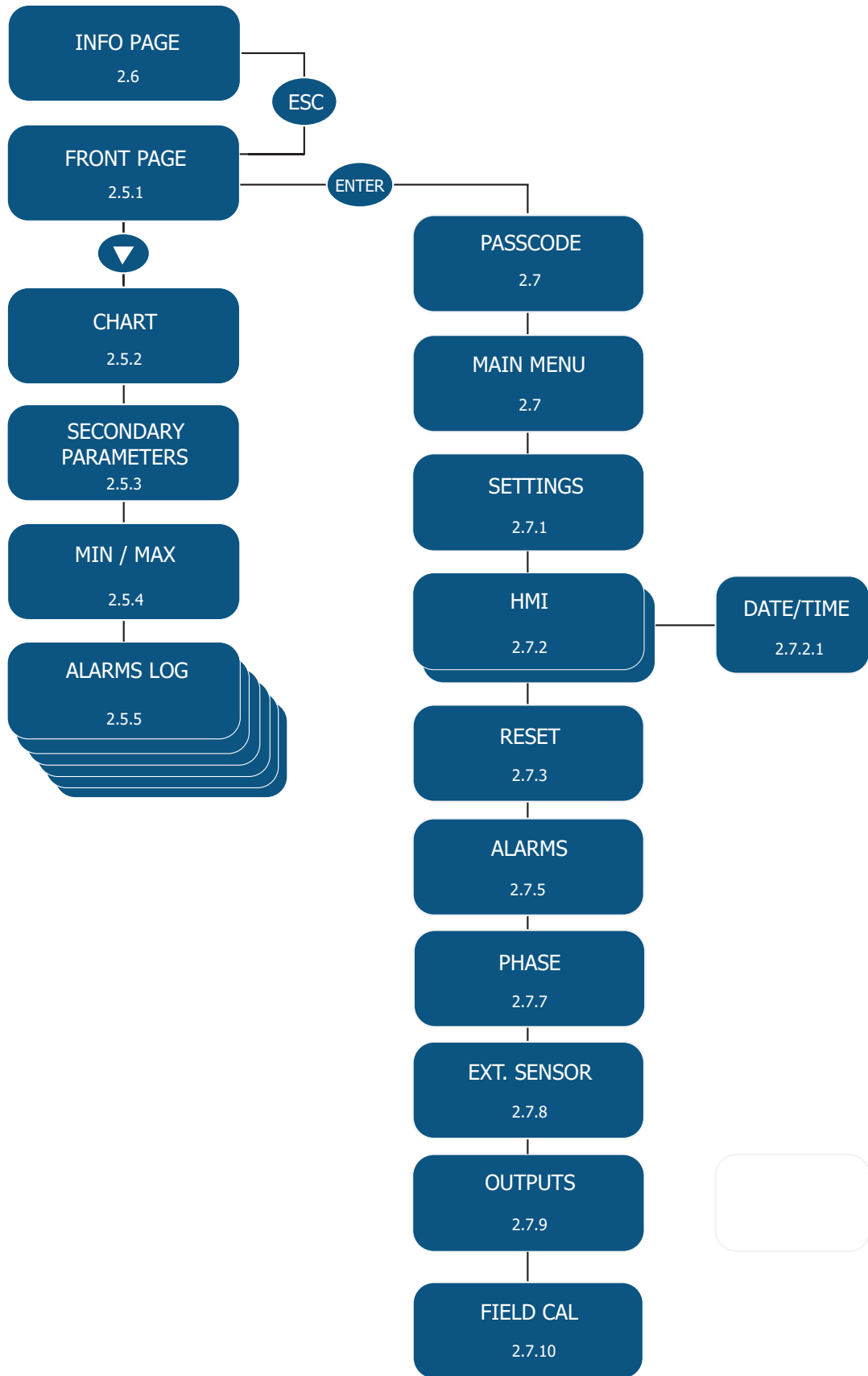

Figure 10 Menu Map – HCG version

2.5 Front Pages (No Passcode Required)

The EX1 and GP1 versions of the XTC601 have 5 front pages that the user can display without the need for a passcode. **NOTE: These are for display of information only and there is no way of adjusting any settings on these pages.**

From the Main Page (Target Gas concentration) the rest of the front pages can be accessed using the **Down (▼)** button. To return to the Main Page, either press the **Up (▲)** button the required amount of times or press the **ESC** button.

2.5.1 Main Page

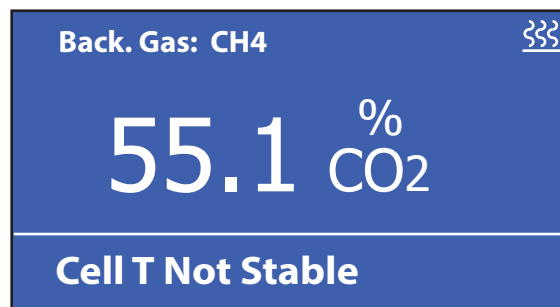

Figure 11 Main page display

Main Page	Description
Background Gas	Displays the background gas the unit was calibrated in
Target Gas	Target Gas reading in %
Heating Symbol	This flashes until cell temperature is stable at set point ± 0.15 °C for minimum of 15 minutes
Status Bar	Flashes any system warnings and error messages (see below)

Table 1 Main page parameters

Status Message Table	
Message (Trigger Condition)	Status LED
Out of range (beyond calibration range, e.g. 0...25%)	N/A
Low alarm ON	ORANGE1 ON (app s/w only)
High alarm ON	ORANGE2 ON (app s/w only)
Comp i/p signal error (input < 3.2 mA or > 21.4 mA)	RED FLASH (priority2)
Ext sens signal error (input < 3.2 mA or > 21.4 mA)	RED FLASH (priority2)
Cell T not stable (not within $\pm 0.15^{\circ}\text{C}$ of set point for continuous period of 15 minutes)	RED ON (priority1)
Cell T sensor error (cell temp measures < -50 or > +80 $^{\circ}\text{C}$)	RED ON (priority1)
PCB temp too high (PCB temp > cell temp set point)	RED ON (priority1)
Phase indication (HCG version only)	Phase 1, 2, 3

Table 2 Status messages

2.5.2 Chart Page

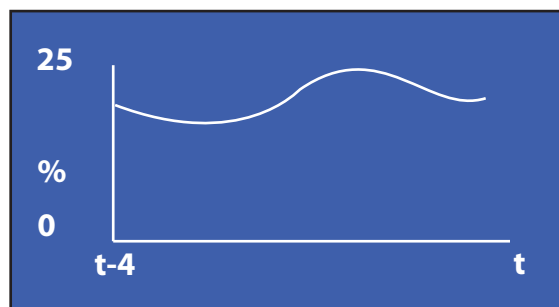

Figure 12 Chart page

- This indicative chart is continuously running at the set Chart Interval (2...60 seconds).
- It is auto ranging with an auto range resolution of 1%.
- It is reset if the Chart Interval is changed or the instrument power is cycled.
- Chart buffer size is 60 values and therefore the chart duration changes according to interval chosen.
- Chart duration in seconds = (Chart interval * 60).
- Chart data is only stored in volatile memory and therefore is not saved. Chart interval is saved and available in a Modbus register.

- Chart data is not available via serial comms or in the blind unit as the Application Software is able to perform more sophisticated charting functions. **NOTE: This data is not available via the Modbus**

2.5.3 Secondary Parameters Page

CELL T, °C	50.0
PCB TEMP, °C	28
COMP I/P	OFF
EXT I/P	OFF

Figure 13 Secondary parameters page

Parameter	Description
CELL T	Sensor cell temperature display in set unit (°C, °F or Kelvin)
PCB TEMP	Temperature display of Microcontroller in selected temperature unit This gives an indication of the internal GUB temperature
COMP I/P (standard version only)	The value of compensation input (mA i/p channel 1) as a % (4 mA=0% and 20 mA=100%) OFF displayed instead of value if external compensation is turned off
PHASE I/P (HCG version only)	Displays the value of the Phase Selection Input in mA (mA i/p channel 1) OFF displayed instead of value if phase selection set to 'Internal'
EXT I/P	Value of the external input in the selected parameter and unit (DEWP, TEMPR, PRESS, OTHER or NONE) OFF displayed instead of value if external compensation parameter is set to NONE

Table 3 Secondary parameters

2.5.4 Target Gas Min/Max Page

MINIMUM	0.00	%CO2
D12/01	T	19:29:44
MAXIMUM	0.00	%CO2
D12/01	T	19:29:44

Figure 14 Target gas min/max page

This indicates the minimum and maximum Target Gas values measured, along with date/time of occurrence. The value is reset manually via the Reset Page in the User Menu. This data is not saved in NV memory and is not available via serial communications or in the blind unit.

NOTE: In the HCG version, the value is reset each time the phase is changed.

2.5.5 Alarms Log Pages

ALARM	DATE	TIME	P1
LOW	02/01	12:50:40	
HIGH	02/01	11:10:32	
LOW	02/01	11:00:29	
HIGH	02/01	10:20:00	

Figure 15 Alarms log page

A maximum of 40 High/Low alarms, along with date and time of occurrence, are recorded in a ring buffer in NV memory. The most recent alarm will overwrite the oldest alarm when more than 40 alarms are recorded. The data is displayed over a maximum of 10 pages (with 4 alarms on each page). The latest alarm record is displayed in line 1 of page 1. This data is not available via serial communications or in the blind unit. The data is reset manually via the Reset Page in the User Menu. The data is saved and restored when the instrument is restarted.

2.6 Info Page

Firmware Ver	1.01
Hours Used	125
Last Cal Date	04:01:14 M
ModBus Rx Code	---

Figure 16 Info page

From the Main Page it is possible to get to the Info Page by pressing the **ESC** button.

Parameter	Description
Firmware Ver	Indicates the firmware version installed in the instrument
Hours used	Indicates the number of hours that the instrument has been powered up
Last Cal Date	The date of the last field or Michell Calibration Character indicates F for Field and M for Michell
ModBus Rx Code	The received Modbus function code is flashed here as soon as a function code is received – this is useful to check the Modbus communications to ensure that good data is coming through. If no code is received then '---' is displayed

Table 4 Info page parameters

2.7 User Set-Up Variables (Passcode Required)

In order to change any settings on the User Menu pages, the user must enter a passcode. There is also a separate passcode for service engineers to allow factory setting changes.

To access the User Menu press the **ENTER** button from the Main Page to call up a passcode prompt. Use the **Up (▲)** and **Down (▼)** buttons and press **ENTER** after each value.

The User Passcode is: 1919

SETTINGS	EXT COMP.
HMI	EXT SENS.
RESET	OUTPUTS
ALARMS	FIELD CAL

Figure 17 *User menu (Standard version)*

SETTINGS	PHASE
HMI	EXT SENS.
RESET	OUTPUT
ALARMS	FIELD CAL

Figure 18 *User menu (HCG version)*

Use the **Up (▲)** and **Down (▼)** buttons to select the sub-menu required. Then press the **ENTER** button. This will give access to one of the following pages.

2.7.1 Settings Page

FIELD CAL	ON/OFF
EXT COMP	ON/OFF
LIMIT 0-100%	ON/OFF
MODBUS ID	1/128

Figure 19 Settings page (Standard version only)

The analyzer is microprocessor-based and, as such, has settings and features accessible to the user.

Select the parameter required. The options will be highlighted and can be toggled between by pressing the **ENTER** button. These are all **ON/OFF** except for Modbus ID which, if only one analyzer is connected to your system, should be set to '1'.

Parameter	Description/Operation	Options
FIELD CAL	When enabled, the field calibration corrections will be applied. When disabled, the factory calibration will be used. For HCG version, this option only applies to Phase 1. It is automatically turned off when Michell or field calibrations are being performed	ON/OFF
FIELD CAL 2 (HCG version only)	When enabled, the field calibration corrections for phase 2 will be applied. When disabled, the factory calibration will be used.	ON/OFF
FIELD CAL 3 (HCG version only)	When enabled, the field calibration corrections for phase 3 will be applied. When disabled, the factory calibration will be used.	ON/OFF
EXT COMP (Standard version only)	Turn external sensor compensation on or off It is automatically turned off when Michell or field calibrations are being performed	ON/OFF
LIMIT 0-100%	Limits the % Target Gas so that any drift below 0.00 and above 100.00 (for suppressed zero) is not visible mA outputs are also limited accordingly	ON/OFF
Modbus ID	Unit's network address for Modbus communications	1-128

Table 5 Settings parameters

NOTE: The HCG settings page does not include EXT COMP option.

2.7.2 Human Machine Interface (HMI) Page

CONTRAST	0-100%
BRIGHTNESS	0-100%
TEMPR UNIT	C/F/K
EXT PRESS UNIT	psia, bara, kpa
CHART INTVAL	2-60s
DATE	DD/MM/YY

Figure 20 HMI page

It is possible to change parameters within the HMI, as in table 6:

Parameter	Description/Operation	Options
CONTRAST	LCD contrast setting	0–100% in 10% steps
BRIGHTNESS	LCD backlit setting	0–100% in 10% steps
TEMPR UNIT	Global temperature unit selection	°C, °F, K
EXT PRESS UNIT	Pressure unit selection (for external sensor only)	psia, bara, kPa
CHART INTVAL	Chart interval	2–60 s in 2 sec steps
DATE	Date on the LCD can be displayed one of two ways	DD/MM/YY or MM/DD/YY

Table 6 HMI parameters

2.7.2.1 Date and Time Page (scroll down past date in HMI page)

HOURS	00-23
MINS	00-59
DAY	1-31
MONTH	1-12
YEAR	00-99
LIVE CLOCK	**.*.*.*

Figure 21 *Date and Time Page*

The real time clock and calendar is used to store date/time information for log data, min/max data and date of calibration. On entering this page all fields are initialized with the current values.

Parameter	Description/Operation	Options
HOURS	Hours	00–23
MINS	Minutes	00–59
DAY	Day	1–31
MONTH	Month	1–12
YEAR	Year	00–99
LIVE CLOCK	Current Time	**.*.*.*

Table 7 Date and Time Page parameters

NOTE: This can be set via the Application Software and can accept the computer’s time as the default time and date.

2.7.3 Reset Page

MIN/MAX	RESET?
ALARM LOGS	DELETE?
FIELD CAL	DELETE?

Figure 22 *Reset page*

Min/Max and Alarm Logs can be cleared from this menu. See Sections 2.5.4 and 2.5.5 respectively for more information.

This menu can also be used to restore the original calibration settings. For more information see Section 3.3.

To reset/delete highlight the item use the **Down (▼)** button. Press **ENTER** to select the option, then press the **Up (▲)** button 3 times to confirm the change. Press **ENTER** to deselect the option.

2.7.4 Alarms Page

The analyzer is supplied with two alarm relays; Single Pole Change-Over (SPCO) which are freely assignable within the calibrated range. The alarm relays are rated to 250 V, 5 A maximum.

AL1 SETPOINT	0.00	%
AL1 CONFIG	LOW	
AL1 TEST	TOGGLE	
AL2 SETPOINT	10.00	%
AL2 CONFIG	LOW	
AL2 TEST	TOGGLE	

Figure 23 Alarm page

Parameter	Description/Operation	Options
AL1 SETPOINT	Setting the concentration at which alarm is triggered.	0–100%
AL1 CONFIG	Allows user to set alarm type or turn off.	OFF, LOW, HIGH
AL1 TEST	Allows user to test the alarm function by highlighting and pressing the up arrow.	N/A
AL2 SETPOINT	Setting the concentration at which alarm is triggered.	0–100%
AL2 CONFIG	Allows user to set alarm type or turn off.	OFF, LOW, HIGH
AL1 TEST	Allows user to test the alarm function by highlighting and pressing the up arrow.	N/A

Table 8 Alarm page parameters

2.7.5 Alarm page (HCG version only)

ALARM	H2/AIR
AL1 SETPOINT	0-100 %
AL1 CONFIG	ON/OFF
AL2 SETPOINT	0-100 %
AL2 CONFIG	ON/OFF

Figure 24 Alarm page (HCG version only)

This page allows the user to configure alarm trip points for each of the two relay contacts.

Alarms for each of the three phases can be configured and each contact can have an alarm value assigned to it for each of the three phases.

Parameter	Description/Operation	Options
ALARMS (HCG version only)	Changes which phase alarms are displayed for	H ₂ /CO ₂ , CO ₂ /AIR, H ₂ /AIR
AL1 SETPOINT	Changes the setpoint for AL1 in the current phase	0–100%
AL1 CONFIG	Changes between low or high trigger. Off disables the contact	LOW, HIGH, OFF
AL2 SETPOINT	Changes the setpoint for AL2 in the current phase	0–100%
AL2 CONFIG	Changes between low or high trigger. Off disables the contact	LOW, HIGH, OFF

Table 9 Alarm parameters (HCG version)

2.7.6 External Compensation Page (standard version only)

COMP 20%	0.50-2.00
COMP 40%	0.50-2.00
COMP 60%	0.50-2.00
COMP 80%	0.50-2.00
COMP 100%	0.50-2.00

Figure 25 External Compensation page

A 4...20 mA sensor may be used to compensate the % Target Gas reading for the effects of process variables such as line pressure, flow, etc. The table of compensation factors may be edited for 5 points along the compensation sensor range. The values would be determined by applying the process variable at each point and noting the effect on the % of Target Gas.

For example: a compensation is needed for line pressure. A 4...20 mA line pressure sensor would be ranged over the compensation range. While the instrument reads a fixed % Target Gas value, a table is created (see example below) while varying the pressure at 20% of range intervals.

At each point the compensation factor can be set between 0.5 and 2.

Pressure	% of Pressure span	TG reading	Effect = (affected value / non affected value)	Compensation factor = 1 / effect
0	0%	20.91	20.91/20.91=1.00	1.00
1	20%	21.65	21.65/20.91=1.04	0.96
2	40%	23.56	1.13	0.88
3	60%	25.99	1.24	0.81
4	80%	29.66	1.42	0.70
5	100%	38.85	1.86	0.54

Table 10 Compensation

The compensation factor values are then entered into the External Compensation table (excluding the 0% point as this will always be assumed to be 1 = no effect).

Below 0% (< 4 mA), the compensation factor is fixed to 1. Above 100% the compensation factor is extrapolated beyond the last factor.

2.7.7 Phase Page (HCG version only)

CONTROL	HMI/MBUS
PHASE	H2/AIR

Figure 26 *Phase page*

This page allows for the user to change the currently measured phase.

The user can also choose between internal phase control (via the screen) or external control via the 4...20 mA input.

Parameter	Description/Operation	Options
CONTROL	Selects how the phase selection is controlled	HMI/MBUS or EXT. (mA Input)
PHASE	Selects the phase	H ₂ /AIR, H ₂ /C ₂ or CO ₂ /AIR

Table 11 Phase parameters

For details on external control of the phase, please see section 4.5.7.

2.7.8 External Sensor Page

EXT.SENS PV	NONE
EXT.SENS MIN	N/A
EXT.SENS MAX	N/A
UNIT = N/A	

Figure 27 External sensor page

This page sets up the type and range of the 4...20 mA external sensor signal that may be connected to the XTC601 for viewing in the Main Page. The range is adjustable between the MIN and MAX values but is not adjustable for **Other** setting (fixed at 0% and 100%).

Parameter	Description/Operation	Options
EXT.SENS PV	The process variable that is being measured by the external sensor The options available are: NONE – No external sensor connected DEWP – Dewpoint TEMPR – Temperature PRESS – Pressure OTHER – User-defined variable	NONE, DEWP, TEMPR, PRESS, OTHER
EXT.SENS MIN	Depends on parameter and unit settings: Dew point: -100 °C, -148 °F, 173.0 K Temperature: -50 °C, -58 °F, 223.0 K Pressure: 0.0 psia, 0.0 bara, 0.0 kpa Other: 0% (non adjustable)	minimum to EXT.SENS MAX
EX.SENS MAX	Depends on parameter and unit settings: Dew point: 20 °C, 68 °F, 293.0 K Temperature: 100 °C, 212 °F, 373.0 K Pressure: 44.1 psia, 3.0 bara, 304.0 kpa Other: 100% (non adjustable)	EXT.SENS MIN to maximum
UNIT	These are related to the type of sensor selected If Other is selected, then the unit will be a % of the overall range	°C, °F, K, psia, kPa, bara, %

Table 12 External sensor parameters

2.7.9 Outputs Page

CH1 TRIM Z	660	
CH1 TRIM S	3300	
CH2 TRIM Z	660	
CH2 TRIM S	3300	
CH2 ZERO	0.00	%
CH2 SPAN	10.00	%

Figure 28 Outputs page

The analyzer has two 4...20 mA outputs and 2 concentration alarm relays. The primary 4...20 mA is fixed to the calibrated range of the unit, the second is freely selectable within this range. When the analyzer is connected to a multimeter or your control system by highlighting any of the lines CH1 ADCZ to CH2 ADCS the analyzer will output for 4 mA or 20 mA on the selected channel. Using the up and down arrows it is possible to trim the actual outputs to ensure they match the displayed values.

Parameter	Description/Operation	Options
CH1 TRIM Z	Analog to digital count for CH1 for output adjustment at 4 mA	0-4095
CH1 TRIM S	Analog to digital count for CH1 for output adjustment at 20 mA	0-4095
CH2 TRIM Z	Analog to digital count for CH2 for output adjustment at 4 mA	0-4095
CH2 TRIM S	Analog to digital count for CH2 for output adjustment at 20 mA	0-4095
CH2 ZERO	% point for 4 mA	0...100%
CH2 SPAN	% point for 20 mA	0...100%

Table 13 Outputs parameters

2.7.9.1 NAMUR Output Set-Up

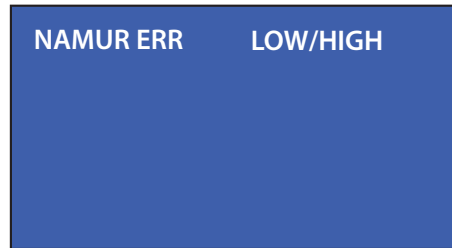

Figure 29 *NAMUR ERR Page*

During initial warm up, or in the event of a sudden change of cell temperature beyond 0.5 °C from the set point, the mA output will be driven to an alarm state of either LOW (3.5 mA) or HIGH 21.4 mA according to the user NAMUR ERR output setting. This complies with the NAMUR convention.

Setting	Description/Operation	Options
NAMUR ERR	Will drive mA output high or low if cell temperature is out of tolerance.	Low/High

2.7.10 Field Cal Page

CAL TYPE	1/2 POINT
REF GAS 1	0.00-100.00
ACTUAL 1	0.00-100.00
REF GAS 2	0.00-100.00
ACTUAL 2	0.00-100.00
Adjusted% ~	0.00-100.00

Figure 30 *Field Cal page*

In the HCG version, the calibration parameters shown in Table 13 will be for the currently selected phase.

Parameter	Description/Operation
CAL TYPE	1 POINT or 2 POINT
REF GAS 1	Cal reference gas for 1-point cal Must be lower than REF GAS 2 (if 2-point cal selected)
ACTUAL 1	Is the uncorrected value post adjustment relative to the factory calibration? See Section 3.1
REF GAS 2	Upper cal reference gas for 2-point cal Disabled if 1-point cal selected
ACTUAL 2	Is the uncorrected value post adjustment relative to the factory calibration? See Section 3.2
Adjusted% ~	TG% reading before then after calibration

Table 14 Field Cal parameters

See Section 3 for field calibration procedure.

2.7.11 Status LED or Light Guide

The Status LED or Light Guide options have identical functionality and take their input from the same board. Therefore, only one of them can be selected.

For either option the information available is as follows:

Power LED

- Green LED On – indicates instrument power is on.

Status LED

- Red LED flashing – indicates when external compensation input or external sensor is out of range (if either is selected to **ON**). Out of range is <3.2 mA or >21.4 mA (see Status Message Table in Section 2.5.1).
- Red LED On – indicates an internal sensor error or instrument cell temperature not yet stabilized (see Status Message Table in Section 2.5.1) – for LED indication this takes priority over external errors.

These have been designed to follow the NAMUR standard.

3 CALIBRATION

3.1 Factory Calibration

The unit is factory calibrated at 5 points (per phase) to maximize the accuracy over the desired range. The calibration generally includes Zero & Span points as well as 3 intermediate points. In the case of suppressed zero ranges the lowest concentration will replace the Zero Point.

3.2 Field Calibration

Like all process analyzers, the XTC601 will require periodic calibration. The frequency entirely depends on the location, application and accuracy requirements of the user. The typical calibration period is expected to be between 1 and 3 months. If the calibration period is in excess of 1 month Michell recommends a Zero and Span calibration. The user should establish a calibration frequency to ensure that the reading is within the specifications required for the process.

NOTE: It is possible to switch off the Field Calibration and revert to the Factory Calibration. This can be useful for diagnostic purposes if the reading is not what is expected. The unit is delivered with a factory calibration and, as such, would not have any field calibration data. As soon as the first field calibration is performed, the field calibration setting is automatically switched on. To switch off field calibration refer to Section 3.7, Field Calibration Reset.

For the HCG version, the calibration settings shown apply to the currently selected phase. In order to perform a field calibration on each phase it will be necessary to repeat the process three times.

3.3 Before Calibration

Zero and Span gas cylinders with correct regulation and flow control should be in place before installing and powering up the analyzer. Commissioning should include a check with both gases and, if necessary, a field calibration performed.

All **standard** analyzers are factory **calibrated with a flow** of 300 ml/min (0.63 scfh) with a nominally atmospheric vent (50 to 100 mbar back-pressure). During commissioning or routine field adjustment, the calibration gas applied to the analyzer should be at the same pressure and flow rate as the process gas to be sampled.

Note: unless specifically factory calibrated otherwise, this analyzer should be operated at atmospheric pressure.

3.4 Calibration Pressure / Flow Rate

General Purpose units:

- Sample Inlet Pressure: Constant from 0 to 2 barg (0 to 29 psig)
- Sample Flow Rate: Stable from 100 to 500 ml/min (0.25 to 1.0 scfh)

Ex or GP units with flame arrestors:

- Sample Inlet Pressure: 50...350 mbarg (0.5...5 psig)
- Sample Flow Rate: 270...330 ml/min (0.57...0.7 scfh)

3.5 1-Point Calibration

This is a single point offset overlaid on top of the factory calibration. It is designed to correct minor drift and minor changes during transit. This calibration makes the unit very accurate at the calibration point and improves accuracy throughout the range.

The calibration gas should be of a value that is within the main area of interest. Example: if main points of interest for a 0...25 % range instrument are around the 6 % area then a suitable calibration gas to apply would be around 6.5 % gas.

1. Apply the calibration gas and purge the unit for at least 5 minutes. View the chart until a flat line shows for 1...2 minutes.

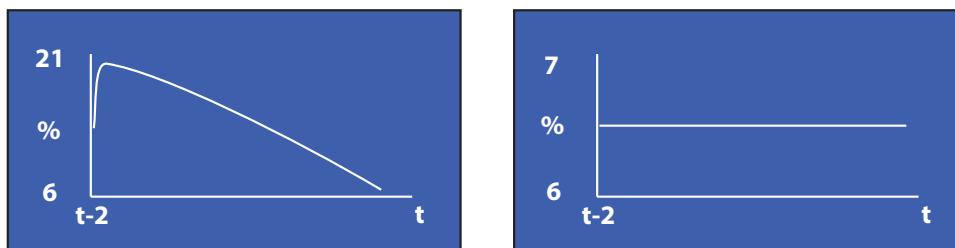

Figure 31 1-Point Calibration Page

2. Press **ENTER** to open the Passcode Page – **1919** Passcode. Navigate to the Field Cal page using the **Up (▲)** button. Press **ENTER** to highlight CAL TYPE and set to 1 POINT. Press **ENTER** to de-select.
3. Press **ENTER** to highlight REF GAS 1 and use the **Up (▲)** and **Down (▼)** buttons to match the value of the concentration of the calibration gas. **NOTE: This value only needs to be set when using a new gas cylinder.** Press **ENTER** to de-select.
4. Ensure the Adjusted value at the bottom of the page has stabilized **NOTE: The value displayed does not change but there will be a ~ symbol next to 'Adjusted' while the reading is stabilizing. When the ~ symbol disappears the reading will be stable and the next change can be made.**
5. Press **ENTER** to highlight ACTUAL 1 value and press the **Up (▲)** button

- 3 times. Ensure that the Adjusted value is now equal to the REF 1 value ($\pm 0.01\%$). Press **ENTER** to de-select. Press **ESC** to return to the Main Menu.
- 6. The Adjusted reading will now be the same as that displayed on the Main Page and be equal to the calibration gas.
- 7. The calibration process is complete. Return to sampling the process gas.

3.6 2-Point Calibration

This is a 2-point adjustment that is overlaid on top of the factory calibration. It is designed to correct minor drift and minor changes during transit. This calibration makes the unit more accurate throughout the range than the single point calibration.

- 1. Apply the lower calibration gas and purge the unit for at least 5 minutes. View the chart until a flat line shows for 1...2 minutes.

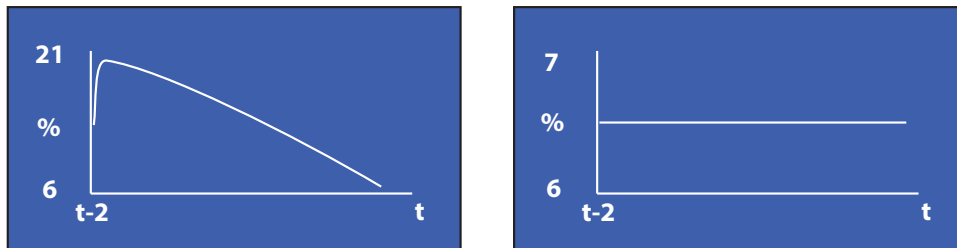

Figure 32 2-Point Calibration Page

- 2. Press **ENTER** to highlight CAL TYPE and set to 2 POINTS. Press **ENTER** to de-select.
- 3. Press **ENTER** to highlight REF GAS 1 and use the **Up** (**▲**) and **Down** (**▼**) buttons to match the value of the concentration of the lower calibration gas. **NOTE: This value only needs to be set when using a new gas cylinder.** Press **ENTER** to de-select.
- 4. Ensure the Adjusted value at the bottom of the page has stabilized **NOTE: The value displayed does not change but there will be a ~ symbol next to 'Adjusted' while the reading is stabilizing. When the ~ symbol disappears the reading will be stable and the next change can be made.**
- 5. Press **ENTER** to highlight ACTUAL 1 value and press the **Up** (**▲**) button 3 times. Ensure that the Adjusted value is now equal to the REF 1 value ($\pm 0.01\%$). Press **ENTER** to de-select.
- 6. Apply the upper calibration gas and purge the unit for at least 5 minutes. View the chart until a flat line shows for 1...2 minutes (see above).

7. Press **ENTER** to highlight REF GAS 2 and use the **Up** (▲) and **Down** (▼) buttons to match the value of the concentration of the upper calibration gas. **NOTE: This value only needs to be set when using a new gas cylinder.** Press **ENTER** to de-select.
8. Ensure that the Adjusted value at the bottom of the page has stabilized.
9. Press **ENTER** to highlight ACTUAL 2 value and press the **Up** (▲) button 3 times. Ensure that the Adjusted value is now equal to the REF 2 value ($\pm 0.01\%$). Press **ENTER** to de-select. Press **ESC** to return to the Main Menu.
10. The Adjusted reading will now be the same as that displayed on the Main Page and be equal to the upper calibration gas.
11. The calibration process is complete. Return to sampling the process gas.

NOTE: The Live % TG reading will now be the same as that displayed on the Main Page and be equal to the upper calibration gas.

3.7 Field Calibration Reset

If the analyzer is displaying a different value to the expected reading, it is possible to restore the unit to the original calibration settings it left the factory with. The analyzer will still require calibration, but this will be made easier as the reading will be forced back into the correct range.

This feature is accessed by selecting the Reset Page (see below).

MIN/MAX	RESET?
ALARM LOGS	DELETE?
FIELD CAL	DELETE?

Figure 33 *Reset page*

Select Field Calibration and press **ENTER** to highlight **DELETE?**, then press the **Up** (▲) button 3 times to confirm the change. Press **ENTER** to deselect the option.

4 INSTALLATION

Before installing the analyzer, read through this manual carefully and take note of all warnings.



The XTC601-EX versions must only be installed by suitably qualified personnel and in accordance with the instructions provided and the terms of the applicable product certificates.

Maintenance and servicing of the product must only be carried out by suitably trained personnel or returned to an approved Michell Instruments' Service Center.



Before the cover is refitted, the flamepath/threaded joint between the cover and body must be thoroughly wiped clean of dirt, grit or other foreign substances and then a thin coating of an approved form of non-setting grease applied to joint/threads. Ensure O-ring is free from damage.

Threaded covers must be screwed down until fully tight (at least 7 full turns) and then locked in position with the hex key provided.



The terms of the Hazardous Area Certification do not permit oxygen measurement in ambient areas with enriched oxygen

4.1 Unpacking

If sold separately (not part of a sampling system), the XTC601 will be supplied in a custom box which should be retained for future use (such as service return). The box contains a small carton containing 2 lid keys and 1 hex key (for the grub screw). Any cable glands supplied will also be in the smaller carton.

Contents:

- XTC601 Binary Gas Analyzer
- Test result sheet
- Carton (containing: 2 x lid keys and 1 x hex key)
- Cable entry options (if ordered)

4.2 System Components

The XTC601 Binary Gas Analyzer benefits from a modular construction, with the major parts of the analyzer shown below:

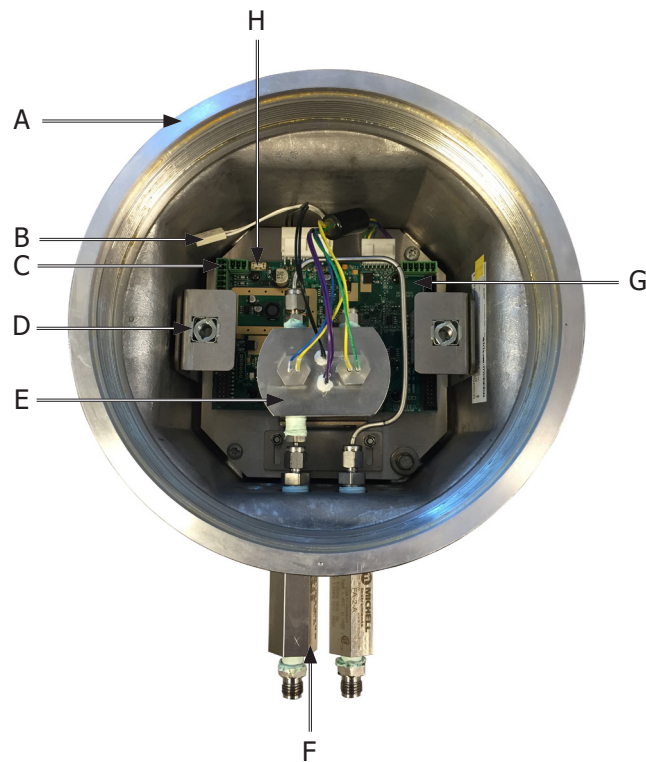

Figure 34 XTC601 Showing Major Components

- A Instrument case
- B Thermal cut-out fuse
- C Power supply (24 V DC) connector (PL9)
- D Quick release mechanism for display PCB
- E Measuring cell
- F Sample gas inlet and outlet
- G Motherboard
- H Main power supply fuse

4.3 Set-Up

- The XTC601 is designed to be panel or wall mounted. There are 2 bolt holes and 2 lugs (1 per corner) see *Figure 11*. Dimensional drawings can be found in Appendix B. Mount the analyzer before attempting to remove the lid.



WARNING: This unit is 24 V DC powered only!

- The EXd thread is greased and therefore it may be advisable to wear latex gloves.
- Ensure that the grub screw is loose, using the hex key (supplied), to prevent scoring on the casing.
- Connect the earthing strap to the earth point on the right hand side of the case.
- Remove the lid, using the lid keys (supplied). The lid will require a firm grip to loosen.

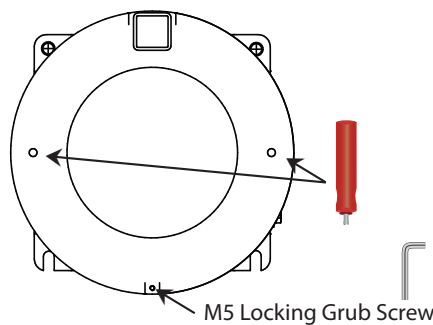

Figure 35 XTC601 Lid Removal

- If fitted, remove the display / status pcb via the two ¼ turn quick-connect fittings.
- Disconnect the ribbon / interconnecting cable from the loose pcb.



WARNING: Prior to connecting power, ensure the unit is correctly earthed via the earth point on the right hand side of the case.

- Connect to the power and outputs (see Section 4.5).
- After making all necessary connections, reconnect the display / status pcb via the ribbon/interconnecting cable & quick-connect fittings and replace and screw down the lid until fully tight (at least 7 full turns).
- Use the hex key (supplied) to tighten the grub screw.

NOTE: This is necessary in order to adhere to the hazardous area certification requirements.

- For operating instructions refer to Section 2.

4.4 Mechanical Installation



WARNING: Unused cable entries must be appropriately blanked to maintain the integrity of the Exd casing.

There are 3 cable entries on the bottom surface, towards the rear, that can be utilized by the customer in a variety of manners. The following standard options are available: Cable Gland, Conduit Entry, Blanking Plug or Light Guide.

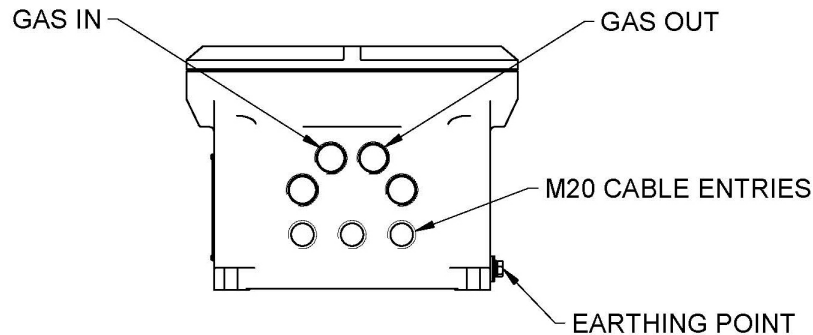

Figure 36 XTC601 Gas Connections and Cable Entries

4.4.1 Gas Connection Tape

The gas connections are on the bottom surface towards the front of the unit, these are 1/4" NPT for GP1 models and 1/8" NPT for Ex and GP2 models.



For applications where the oxygen concentration is classed as enriched (>21% O₂) any PTFE tape used must be unsintered. This is to prevent an explosion due to conventional PTFE tape acting as a potential fuel source.

Unsintered PTFE tape is available as an accessory from Michell Instruments (PTFE-TAPE-02).

4.4.2 Sample Gas Requirements

Samples must have a dew point at least 5 °C less than the cell temperature (so as not to condense), be free from oil-mist and with particle size < 3µm.

NOTE: There is NO filtration inside the analyzer.

GP models

- Sample Inlet Pressure: Constant from 0 to 0.5 barg (0 to 7 psig)
- Sample Flow Rate: Stable from 100 to 500 ml/min (0.25 to 1.0 scfh)

Ex models

- Sample Inlet Pressure: 50...350 mbarg (0.5...5 psig)
- Sample Flow Rate: 270...330 ml/min (0.57...0.7 scfh)

4.4.3 Calibration Gases

Cylinders of the appropriate Zero and Span gases should be available for installation and commissioning. Dependent on the specific duty of the analyzer, these gases may have a lead time of several weeks.

See Section 3 for more information. Contact your local Michell representative for information on finding a local gas supplier.

4.5 Electrical Installation

4.5.1 Power Supply and Input/Output Signal

The XTC601 requires 24 V DC power input at a maximum start-up current of 1.5 A. **Warning: DO NOT attempt to loop power this analyzer.**

All versions will use a braid screened multi-core cable. Ideally, one cable for signals (PL4, PL5) and another cable for power (PL9) / relay contacts (PL1). Braid of cables must be well terminated at the cable glands. Wire sizes should be between 28 and 16 AWG.

The terminal blocks for the power supply, input signal and output signal are located underneath the lower PCB. **NOTE: The terminal blocks are color co-ordinated to match the connectors – make sure this color coding is adhered to.**

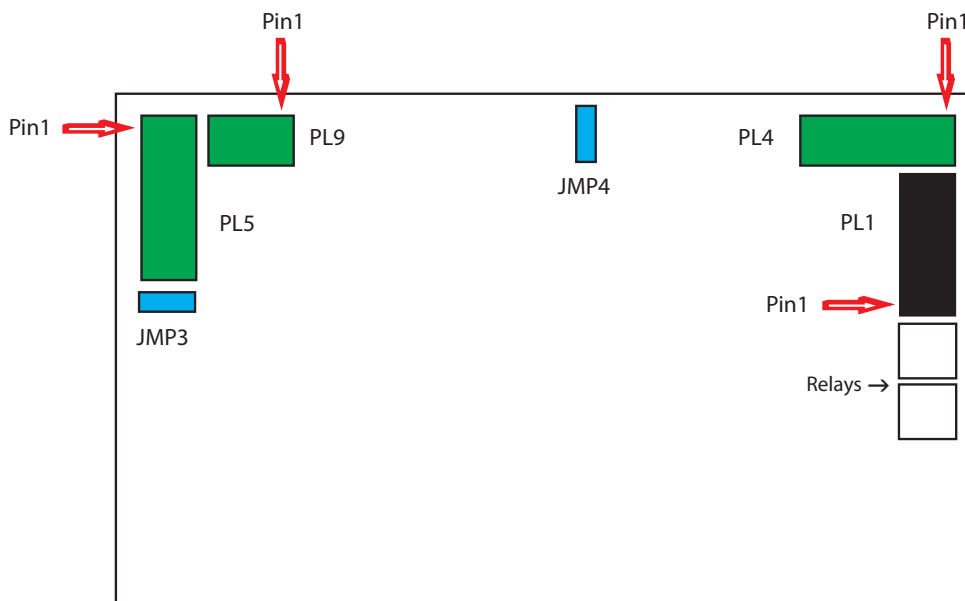

Figure 37 Terminal Block Locations

4.5.2 Power Supply (PL9 – Green)

PIN 3	PIN 2	PIN 1
0 V	N/C	24 V ±4 V

4.5.3 Analog Output

Warning: DO NOT attempt to loop power this analyzer.

Two 4...20 mA analog outputs are available. Both are for Binary Gas concentration. One is fixed on the calibrated range of the unit and the second can be configured in the menu. **NOTE: When the instrument is warming up (cell temperature not stabilized) these outputs are set to 3.5 mA to indicate that the instrument is not ready.**

- The maximum mA output is approximately 25 mA
- The minimum mA output is approximately 0 mA

4.5.4 Serial Output

The analyzer has Modbus RTU communications over RS485; please see Application Software CD for more details.

- Type: Modbus RTU over RS485
- RS485: 2 wire (plus ground), half duplex
- Baud Rate: 9600
- Parity: None
- Data bits: 8
- Stop bits: 1

4.5.5 Analog (4...20 mA) Outputs and Communications (PL5 – Green)

PIN 7	PIN 6	PIN 5	PIN 4	PIN 3	PIN 2	PIN 1
RS485 GND	RS485 B	RS485 A	Ch2 O/P -	Ch2 O/P +	Ch1 O/P -	Ch1 O/P +

NOTE 1: For standard version, Channel 1 is fixed range output over instrument range and Channel 2 is adjustable within instrument range.

NOTE 2: For HCG version, Channel 1 is concentration for currently selected phase. Channel 2 indicates the selected phase. Channel 2 indication: Phase 1 = 8mA; Phase 2= 12mA; Phase 3 = 16mA

NOTE 3: For long cable lengths, a termination resistor of 120Ω is provided to aid in impedance matching of the communications cable. This is selectable via JMP3. A terminating resistor is simply a resistor placed at the extreme end or ends of a cable on an RS485 network to reduce effects of impedance mismatch. Impedance mismatch can cause reflections of data as it passes down the cable and the reflections could be large enough to cause data errors.

4.5.6 Alarm Relay Contacts (PL1– Black)

PIN 6	PIN 5	PIN 4	PIN 3	PIN 2	PIN 1
Hi Alarm C	Hi Alarm NO	Hi Alarm NC	Low Alarm C	Low Alarm NO	Low Alarm NC

- Type: SPCO (NO, NC and C)
- Contact Rating, Max: 5 A, 250 V
- Hysteresis is 0.03 %
- AL1 and AL2 can be configured as OFF, LOW or HIGH
- A low alarm switches on when % O₂ is below the set point and switches off when % O₂ is above the set point + Hysteresis

- A high alarm switches on when % O₂ is above the set point and switches off when % O₂ is below the set point – Hysteresis
- When the instrument is warming up (cell temperature not stabilized) both relays are OFF

4.5.7 Analog (4...20mA) Inputs and Sensor Excitation Voltage(PL4 – Green)

PIN 6	PIN 5	PIN 4	PIN 3	PIN 2	PIN 1
Ch2 I/P -	CH2 I/P +	Ch2 Exc.V	Ch1 I/P -	Ch1 I/P +	Ch1 Exc.V

The XTC601 features 2 input channels for 4...20mA signal from external instruments such as pressure transmitters or other devices to compensate for pressure or background gas influence.

The input configured as **EXT SENS** (External Sensor) can be viewed on the Secondary Parameters Page under the heading **EXT I/P** (External Input).

NOTE 1: Standard Analyzer:

Channel 1 = External compensation input

Channel 2 = External sensor input

HCG Analyzer:

Channel 1 = External phase input

Channel 2 = External sensor input

NOTE 2: Excitation voltage = Same as power supply ± 1 V if JMP4 connected across top 2 pins and 15 ± 0.5 V (max 100mA per channel) if JMP4 connected across bottom 2 pins.

NOTE 3: HCG version only:

To select phases externally, current signals within the following rangesshould be applied to channel 1:

- 1. Phase 1 = 7mA...9mA**
- 2. Phase 2 = 11mA...13mA**
- 3. Phase 3 = 15mA...17mA**

4.5.8 Light Guide

The optional light guide can be fitted to the left hand cable entry. If this is required for the Hazardous Area version of the analyzer this must be specified at time of purchase order. Only one light guide can be fitted to each analyzer.

Appendix A

Technical Specifications

Appendix A Technical Specifications

A.1 Standard XTC601

Performance	
Measurement Technology	Thermal Conductivity sensor
Measured Gases (select one)	CO ₂ , CH ₄ , Ar, He, N ₂ , H ₂ or Air
Gas Requirements	Non-condensing sample with particles <3µm
Measurement Range	Selectable from 0...1 up to 0...100 %; 50...100 % up to 98...100 %
Display Resolution	0.1 % (0.01 % for range ≤ 10 %)
Display Type	Backlit LCD
Intrinsic Error (Accuracy)	< ±2 % of range *
Response Time (T90)	Standard < 20 seconds *
Repeatability	±0.2 % of range
Linearity	±1 % range
Zero Stability	±0.5 % of range per month
Range Stability	±0.5 % of range per month
Sample Flow Rate	100...500 ml/min (0.25...1.0 scfh)
Sample Flow Rate (Ex)	270...330 ml/min (0.57...0.7 scfh)
Sample Pressure	A fixed pressure of 0.75...1.5 Bar A (10...20 psi A) (unit must be calibrated at the same pressure as sample)
Maximum Safe Pressure	1 barg (14.5 psig)
Sample Temperature	0...45 °C (+32...+113 °F) max
Sample Cell Temperature	Standard +50 °C (+122 °F)
Electrical Specifications	
Analog Inputs	1 off mA input for an external sensor (can be displayed on the screen) 1 off mA input to act as an active compensation for the process conditions
Analog Outputs	2 off 4...20mA outputs (powered with 24V excitation voltage)
Output Ranges	Primary range is set to the calibrated range of the instrument The second is user selectable within the primary range
Alarms	2 off single pole changeover (SPCO) relays for concentration (250 V, 5 A max)
Datalogging	The user can use the digital communications to log the output from the analyzer The unit will store 40 alarm points and the min/max concentrations with date and time stamp
Digital Communications	Modbus RTU over RS485
Power Supply	24 V DC; 1.5 A max
Operating Conditions	
Ambient Temperature	5...60 °C (41...140 °F)

Mechanical Specification	
Warm Up Time	< 25 minutes
Stabilization Time	5 minutes
Dimensions	234 x 234 x 172mm (9.2 x 9.2 x 6.7") (w x d x h)
Weight	9.7kg (21.4lbs)
Wetted Materials	316 stainless steel, borosilicate glass, platinum, (plus O-ring)
O-Ring Materials	Viton, Silicone or Ekraz
Gas Connection	1/4" NPT Female (GP1) 1/8" NPT Female (Ex & GP2)
Ingress Protection	IP66, NEMA 4
Hazardous Area Classification – See Appendix F	

* The standard intrinsic error and response time will be as above. Certain gas combinations and/or ranges may have different specifications. Please consult Michell Instruments for specific cases. For example, CO₂ / N₂ would be < 50 seconds for T90.

A.2 XTC601 for Monitoring Hydrogen Cooled Generators

Performance			
Phase	Phase 1 – H₂ in Air	Phase 2 – H₂ in CO₂	Phase 3 – CO₂ in Air
Measurement Range	80...100 % or 90...100 %	0...100 %	0...100 %
Display Resolution	0.01 %	0.1 %	1 %
Response Time (T90)	< 20 seconds	< 20 seconds	< 50 seconds
Recommended calibration	Monthly	Prior to use	Annually
Measurement Technology	Thermal Conductivity sensor		
Gas Requirements	Non-condensing sample with particles <3µm		
Display Type	Backlit LCD		
Repeatability	±0.2 % of range		
Linearity	±1 % range		
Sample Flow Rate	270...330 ml/min (0.57...0.7 scfh)		
Sample Pressure	Analyzers are factory calibrated and must be operated with a nominally atmospheric pressure.		
Maximum Safe Pressure	1 barg (14.5 psig)		
Sample Temperature	0...45 °C (+32...+113 °F) max		
Sample Cell Temperature	Standard +50 °C (+122 °F)		
Electrical Specifications			
Analog Inputs	2 off 4...20mA inputs One to control phase selection One for an external sensor that can be displayed on the screen		
Analog Outputs	2 off 4...20mA outputs: mA 1 = Concentration mA 2 = Phase indication		
Alarms	2 off single pole changeover (SPCO) relays for concentration (250 V, 5 A max)		
Digital Communications	Modbus RTU over RS485		
Power Supply	24 V DC; 1.5 A max		
Operating Conditions			
Ambient Temperature	0...40 °C (32...104 °F)		
Mechanical Specification			
Warm Up & Stabilization Time	< 30 minutes		
Dimensions	234 x 234 x 172mm (9.2 x 9.2 x 6.7") (w x d x h)		
Weight	9.7kg (21.4lbs)		
Wetted Materials	316 stainless steel, borosilicate glass, platinum, (plus O-ring)		
O-Ring Materials	Viton		
Gas Connection	1/8" NPT Female		
Ingress Protection	IP66, NEMA 4		
Hazardous Area Classification – See Appendix F			

Appendix B

Dimensional Drawings

Appendix B Dimensional Drawings

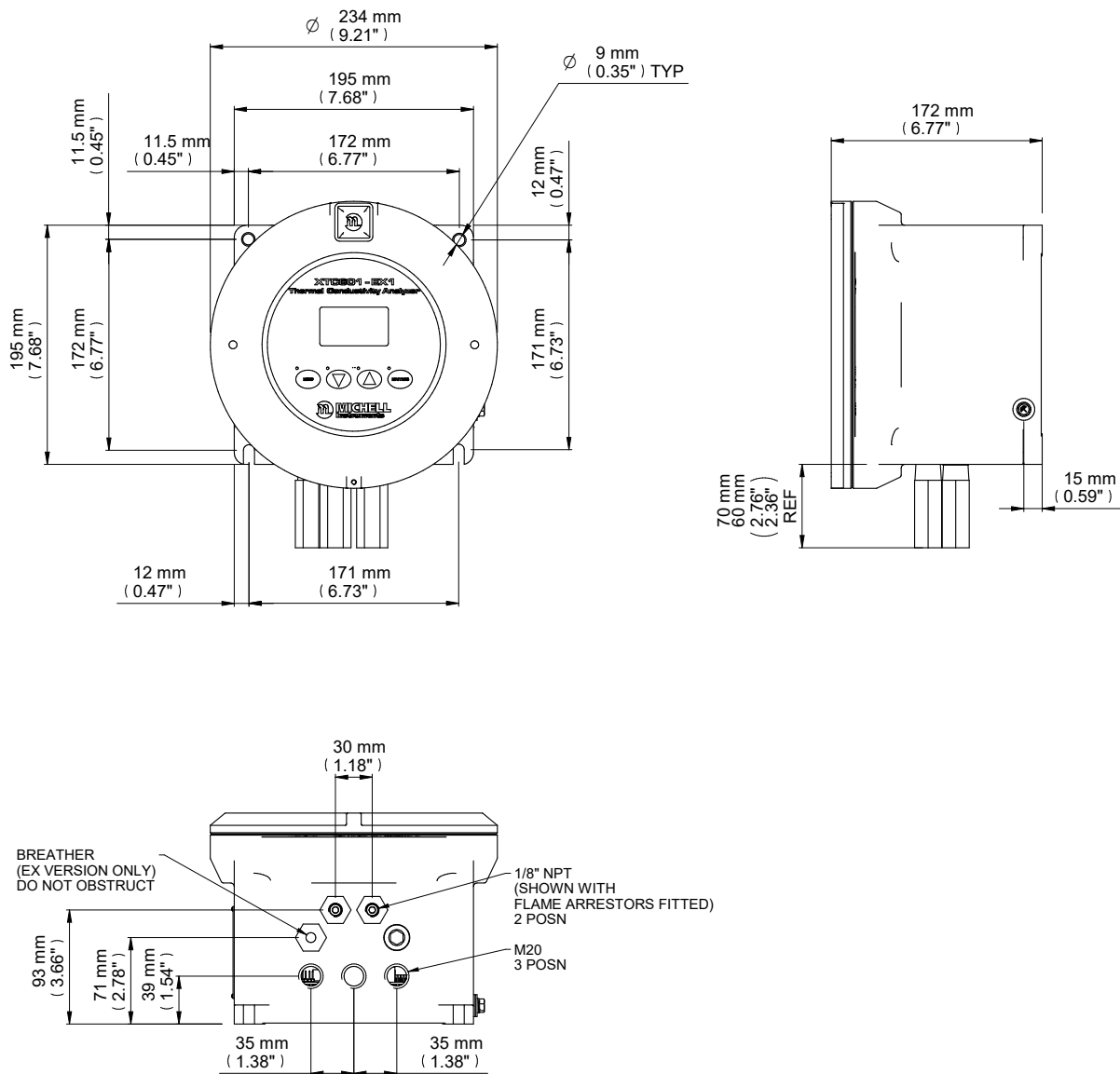

Figure 38 Dimensional Drawings

NOTE: Fixing mounts are NOT symmetrical. This is to ensure correct orientation.

Appendix C

Thermal Conductivity Table

Appendix C Thermal Conductivity Table

Gas	Formula	Temperature=50 °C (122 °F) in mW/(m.K)
Commonly Used Gases		
Hydrogen	H ₂	196.86
Helium	He	163.55
Methane	CH ₄	38.01
Oxygen	O ₂	28.24
Air	N ₂ /O ₂ /Ar	27.64
Nitrogen	N ₂	27.57
Ethane	C ₂ H ₆	24.63
Argon	Ar	18.79
Carbon-dioxide	CO ₂	18.74
Other gases for reference		
Ammonia	NH ₃	27.90
Nitric-oxide	NO	27.57
Acetylene	C ₂ H ₂	24.15
Ethylene	C ₂ H ₄	23.86
Propane	C ₃ H ₈	21.39
Water Vapour	H ₂ O	20.34
Butane	C ₄ H ₁₀	19.39
Hydrogen-sulphide	H ₂ S	15.97
Hydrogen-chloride	HCL	15.66
Sulphur-hexafluoride	SF ₆	14.76
Sulphur-dioxide	SO ₂	10.69

Note: This table is for reference purposes only. Please see order code sheet for what is available.

Appendix D

Modbus Register Map (standard version)

Appendix D Modbus Register Map (standard version)

Compatible with XTC601 Firmware Version: V1:08

Addr	Function	Access	Ranges/Resolution	Type
0	Modbus Instrument Address (ID)	R/W	1...127	A
1	Settings Register	R/W	0...65535	B
2	Display Contrast / Brightness	R/W	0...100 % / 0...100 %, 10 % steps	C
3	Units Register (Tempr, Pressure, Ext Sens, Param, etc)	R/W	See reg details	D
4	Chart Interval	R/W	2...60 sec, in 2 sec intervals	A
5	Background gas in application	R/W	0...23	A
6	Alarm 1 (Lo alarm) Set point	R/W	Instrum range min Instrum range max, 0.01	G
7	Alarm 2 (Hi alarm) Set point	R/W	Instrum range min Instrum range max, 0.01	G
8	Range Zero (Ch1 output zero)	R	0.00 to Range Span	G
9	Range Span (Ch1 output span)	R	Range Zero...100.00	G
10	CH1 comp coefficient 20 %	R/W	0.50...2.00	G
11	CH1 comp coefficient 40 %	R/W	0.50...2.00	G
12	CH1 comp coefficient 60 %	R/W	0.50...2.00	G
13	CH1 comp coefficient 80 %	R/W	0.50...2.00	G
14	CH1 comp coefficient 100 %	R/W	0.50...2.00	G
20	CH2 Input (Ext Sensor) zero	R/W	See reg details	F
21	CH2 Input (Ext Sensor) span	R/W	See reg details	F
22	Main gas in application	R/W	0...23	A
23	Cell Tempr Set point	R	40...70 C	A
27	Alarm / NAMUR Configuration	R/W	See reg details	L
29	Field Cal Reference 1	R/W	Instrument range (min -20 %) to (max +20 %), 0.01	G
30	Field Cal Actual 1	R/W	-199.99...199.99	G
31	Field Cal Reference 2	R/W	Instrument range min to (max +20 %), 0.01	G
34	Language	R/W	0...15	A
37	Field Cal Actual 2	R/W	-199.99...199.99	G
56	CH2 output zero	R/W	Instrument range min to CH2 output span, 0.01	G
57	CH2 output span	R/W	CH2 output zero to instrument range max, 0.01	G
63	Hours Of Operation	R	0...65535	A
64	Restore Factory Settings / Cal data (write 5491 to this reg)	W	5491	A
65	Set Clock HRS	W	00...23	J
66	Set Clock MIN	W	00...59	J
67	Set Clock DAY	W	01...31	J
68	Set Clock MONTH	W	01...12	J
69	Set Clock YEAR	W	00...99	J
70	% Reading of Gas	R	-199.00...199.99 %	G
72	Cell Temperature	R	-99.9...99.9 or equiv in F or K	F
73	PCB temperature	R	-99...99 C or equiv in F or K	K
75	mA1 Input in % (comp signal)	R	0.0...100.0 %	F

Addr	Function	Access	Ranges/Resolution	Type
76	mA2 Input (ext sensor signal)	R	See Reg Details	F
77	Status Flags register	R	0...65535	I
78	Clock HOURS/MIN	R	00...23 / 00...59	J
79	Clock SEC/DAY	R	00...59 / 01...31	J
80	Clock MONTH/YEAR	R	01...12 / 00...99	J
81	% MINIMUM (stats)	R	-199.00...199.99 %	G
82	% MAXIMUM (stats)	R	-199.00...199.99 %	G
83	VCOMP	R	0...8191	A
84	Firmware Version	R	0.00...200.00	G
91	% without field cal correction	R	-199.00...199.99 %	G

Register Type A: Unsigned Integer

15	14	13	12	11	10	9	8	7	6	5	4	3	2	1	0
r/w	r/w	r/w	r/w	r/w	r/w	r/w	r/w	r/w	r/w	r/w	r/w	r/w	r/w	r/w	r/w

Unsigned integer. Range = 0...65535

Background gas or main gas list is:

Air	C3H6	He	NO
Ar	C4H6	Kr	O2
BioG	CH4	N2	SF6
C2H4	CO2	N2O	SynG
C2H6	CO	Ne	Xe
C3H8	H2	NH3	XXXX (not defined)

Register Type B: Settings

15	14	13	12	11	10	9	8	7	6	5	4	3	2	1	0
r/w	r/w	r/w	r/w	r/w	r/w	r/w	r/w	r/w	r/w	r/w	r/w	r/w	r/w	r/w	r/w

Bit	HEX	Meaning
0	0001	Field Cal On
2	0004	External Compensation On
3	0008	Background Gas Compensation On
5	0020	Display Limit 0...100 % On

Register Type C: Display Parameters

15	14	13	12	11	10	9	8	7	6	5	4	3	2	1	0
Display Brightness								Display Contrast							
r/w	r/w	r/w	r/w	r/w	r/w	r/w	r/w	r/w	r/w	r/w	r/w	r/w	r/w	r/w	r/w
0...100 in 10 % steps								0...100 in 10 % steps							

Register Type D: Units

15	14	13	12	11	10	9	8	7	6	5	4	3	2	1	0
r/w	r/w	r/w	r/w	r/w	r/w	r/w	r/w	r/w	r/w	r/w	r/w	r/w	r/w	r/w	r/w

Bits	HEX	Meaning (binary)
0, 1	0003	00=°C, 01=°F, 10=K
2, 3	000C	Ext press unit, 00 = psia, 01=bara, 10=kPa
4	0010	Field cal type, 0=1 gas (offset), 1=2 gas
5	0020	Date format 0=Non US, 1=US
11, 12, 13	3800	Ext Sensor Parameter (000=none, 001=dewp, 010=tempr, 011=press, 100=other)

Register Type F: -2000.0...+2000.0

15	14	13	12	11	10	9	8	7	6	5	4	3	2	1	0
r/w	r/w	r/w	r/w	r/w	r/w	r/w	r/w	r/w	r/w	r/w	r/w	r/w	r/w	r/w	r/w

Range = 0...40000 represents -2000.0...+2000.0

Conversion: $(\text{RegValue} - 20000)/10.0$

For external sensor values

Dew point: -100/+20 °C, -148.0/+68.0 °C, 173.0/293.0 K

Tempr: -50.0/+100.0 °C, -58.0/+212.0 °F, 223.0/373.0 K

Pressure: 0.0/44.1 psia, 0.0/3.0 barA, 0.0/304.0 kpa

Register Type G: -200.00...+200.00

15	14	13	12	11	10	9	8	7	6	5	4	3	2	1	0
r/w	r/w	r/w	r/w	r/w	r/w	r/w	r/w	r/w	r/w	r/w	r/w	r/w	r/w	r/w	r/w

Range = 0...40000 represents -200.00...+200.00

Conversion: $(\text{RegValue} - 20000)/100.00$

Register Type I – Status/Error

15	14	13	12	11	10	9	8	7	6	5	4	3	2	1	0
r	r	r	r	r	r	r	r	r	r	r	r	r	r	r	r

Bit	HEX	Meaning
1	0002	%Gas out of range (beyond calibration range, e.g. 0...25 %)
2	0004	Low alarm ON
3	0008	High alarm ON
4	0010	Ext Comp i/p signal error (input < 3.6mA or > 21mA)
5	0020	Ext sens. signal error (input < 3.6mA or > 21mA)
6	0040	Cell T not stable (not within ± 0.15 °C of setpoint for continuous period of 15 minutes)
7	0080	Cell T sensor error (cell tempr measures <-50 or >80 °C)
8	0100	NA
9	0200	Thermal Conductivity sensor error (Vcomp <=1 or >=8191)
10	0400	PCB tempr too high (PCB tempr > Cell tempr setpoint)

Register Type J

15	14	13	12	11	10	9	8	7	6	5	4	3	2	1	0
r/w	r/w	r/w	r/w	r/w	r/w	r/w	r/w	r/w	r/w	r/w	r/w	r/w	r/w	r/w	r/w

←———— eg Day —————→ ←———— eg Month —————→

For reading each 8 bits represents a RTC value. For setting only the Lower 8 bits are used for each RTC value.

Register Type K: -32767...+32767

15	14	13	12	11	10	9	8	7	6	5	4	3	2	1	0
r/w	r/w	r/w	r/w	r/w	r/w	r/w	r/w	r/w	r/w	r/w	r/w	r/w	r/w	r/w	r/w

Range = 0...65535 represents values
Conversion: (RegValue – 32767)

Register Type L: Alarm Configuration

15	14	13	12	11	10	9	8	7	6	5	4	3	2	1	0
r/w	r/w	r/w	r/w	r/w	r/w	r/w	r/w	r/w	r/w	r/w	r/w	r/w	r/w	r/w	r/w

Bits	Meaning
1, 0	00 = Alarm1 is Inactive (off) 01 = Alarm1 is a Low Alarm 10 = Alarm1 is a High Alarm
3, 2	00 = Alarm2 is Inactive (off) 01 = Alarm2 is a Low Alarm 10 = Alarm2 is a High Alarm
4	0 = Namur Error Level Low (3.2mA) 1 = Namur Error Level High (21.4mA)

Appendix E

Modbus Register Map (HCG version)

Appendix E Modbus Register Map (HCG version)

Compatible with XTC601 HCG Firmware Version: V1:06

NOTE: Addr+1 for Wintech Modbus Activex Control

Addr	Function	APP SW	Ranges/ Resolution	Type	Firmware definition
0	Modbus Instrument Address (ID)	R/W	1...127	A	INST_ID
1	Settings Register	R/W	0...65535	B	SET_FLAGS
2	Display Contrast / Brightness	R/W	0...100 % / 0...100 %, 10 % steps	C	CONTR_BRIGHT
3	Units Register (Tempr, Pressure, Ext Sens, Param, etc)	R/W	See reg details	D	UNITS
4	Chart Interval	R/W	2...60 Sec, in 2 sec intervals	A	CHART_INTERVAL
5	Phase 1 Alarm 1 Set point	R/W	Instrum range min Instrum range max, 0.01	G	PHASE1_AL1
6	Phase 1 Alarm 2 Set point	R/W	Instrum range min Instrum range max, 0.01	G	PHASE1_AL2
7	Range 1 Zero (Ch1 output zero)	R	0.00 to Range Span	G	XTC1_LO
8	Range 1 Span (CH1 output span)	R	Range Zero to 100.00	G	XTC1_HI
9	Phase 2 Alarm 1 Set point	R/W	Instrum range min Instrum range max, 0.01	G	PHASE2_AL1
10	Phase 2 Alarm 2 Set point	R/W	Instrum range min Instrum range max, 0.01	G	PHASE2_AL2
11	Range 2 Zero (Ch1 output zero)	R	0.00 to Range Span	G	XTC2_LO
12	Range 2 Span (Ch1 output span)	R	Range Zero to 100.00	G	XTC2_HI
13	Phase 3 Alarm 1 Set point	R/W	Instrum range min Instrum range max, 0.01	G	PHASE3_AL1
14	Phase 3 Alarm 2 Set point	R/W	Instrum range min Instrum range max, 0.01	G	PHASE3_AL2
15	Range 3 Zero (Ch1 output zero)	R	0.00 to Range Span	G	XTC3_LO
16	Range 3 Span (Ch1 output span)	R	Range Zero to 100.00	G	XTC3_HI
47	CH2 Input (Ext Sensor) zero	R/W	See reg details	F	CH2_EXT_ZERO
48	CH2 Input (Ext Sensor) span	R/W	See reg details	F	CH2_EXT_SPAN
49	Calibration Table Setting	R/W	See reg details	E	XTC_PHASE
50	Cell Temperature Set point	R	40...70 °C	A	CELL_TEMPR_SP
54	Field Cal 1 Reference High	R/W	0.00...100.00	G	FIELD_REF1_HI
55	Field Cal 1 Reference Low	R/W	0.00...100.00	G	FIELD_REF1_LO

Addr	Function	APP SW	Ranges/ Resolution	Type	Firmware definition
56	Field Cal 2 Reference High	R/W	0.00...100.00	G	FIELD_REF2_HI
57	Field Cal 2 Reference Low	R/W	0.00...100.00	G	FIELD_REF2_LO
58	Field Cal 3 Reference High	R/W	0.00...100.00	G	FIELD_REF3_HI
59	Field Cal 3 Reference Low	R/W	0.00...100.00	G	FIELD_REF3_LO
60	Field Cal 1 Actual High	R	0.00...100.00	G	FIELD_ACT1_HI
61	Field Cal 1 Actual Low	R	0.00...100.00	G	FIELD_ACT1_LO
62	Field Cal 2 Actual High	R	0.00...100.00	G	FIELD_ACT2_HI
63	Field Cal 2 Actual Low	R	0.00...100.00	G	FIELD_ACT2_LO
64	Field Cal 3 Actual High	R	0.00...100.00	G	FIELD_ACT3_HI
65	Field Cal 3 Actual Low	R	0.00...100.00	G	FIELD_ACT3_LO
67	Alarm Configuration	R/W	See Reg Details	L	ALARM_TYPES
78	Last Cal Date DATE/MONTH	R	1...31/1...12	J	CAL_DATE_DDMM
79	Last Cal Date: Field or Factory (bit 15) / YEAR (bits0...3)	R	0=Factory, 1=Field / 0...99	J	CAL_DATE_YY
80	Hours of Operation	R	0...65535	A	HOURS_USED
82	Set Clock HRS	W	00...23	J	SET_RTC_HRS
83	Set Clock MIN	W	00...59	J	SET_RTC_MIN
84	Set Clock DAY	W	01...31	J	SET_RTC_DAY
85	Set Clock MONTH	W	01...12	J	SET_RTC_MONTH
86	Set Clock YEAR	W	00...99	J	SET_RTC_YEAR
87	% Reading of Gas	R	-199.00...199.99 %	G	GAS_READING
88	Cell Temperature	R	-99.9...99.9 or equivalent in F or K	F	CELL_TEMPR
89	PCB temperature	R	-99...99 °C or equivalent in F or K	K	INT_TEMPR
90	mA1 Input in % (phase indicator signal)	R	0.0...100.0 %	F	MA_IN1_PERC
91	mA2 Input (ext sensor signal)	R	See Reg Details	F	MA_IN2_VAL
92	Status Flags register	R	0...65535	I	STATUS_REG
93	Clock HOURS/MIN	R	00...23 / 00...59	J	RTC_HRS_MIN
94	Clock SEC/DAY	R	00...59 / 01...31	J	RTC_SEC_DAY
95	Clock MONTH/YEAR	R	0...12 / 00...99	J	RTC_MONTH_YEAR
96	% MINIMUM (stats)	R	-199.00...199.99 %	G	RM_XTCSTAT_MIN
97	% MAXIMUM (stats)	R	-199.00...199.99 %	G	RM_XTCSTAT_MAX
99	Firmware Version	R	0.00...200.00	G	FIRM_VER
105	% without field cal correction	R	-199.00...199.99 %	G	XTC_NO_FIELDCAL

Register Type A: Unsigned Integer

15	14	13	12	11	10	9	8	7	6	5	4	3	2	1	0
r/w	r/w	r/w	r/w	r/w	r/w	r/w	r/w	r/w	r/w	r/w	r/w	r/w	r/w	r/w	r/w

Unsigned integer. Range = 0...65535

Register Type B: Settings

15	14	13	12	11	10	9	8	7	6	5	4	3	2	1	0
r/w	r/w	r/w	r/w	r/w	r/w	r/w	r/w	r/w	r/w	r/w	r/w	r/w	r/w	r/w	r/w

Bit	HEX	Meaning
0	0001	Phase 1 Field Cal On
1	0002	Phase 2 Field Cal On
2	0004	Phase 3 Field Cal On
3	0008	
4	0010	
5	0020	Display Limit 0...100 % On
6	0040	Fault Level Setting, 0=Low, 1=High
7	0080	
8	0100	
9	0200	
10	0400	
11	0800	
12	1000	
13	2000	
14	4000	
15	8000	

Register Type C: Display Parameters

15	14	13	12	11	10	9	8	7	6	5	4	3	2	1	0
Display Brightness								Display Contrast							
r/w	r/w	r/w	r/w	r/w	r/w	r/w	r/w	r/w	r/w	r/w	r/w	r/w	r/w	r/w	r/w
0...100 in 10 % steps								0...100 in 10 % steps							

Register Type D: Units

15	14	13	12	11	10	9	8	7	6	5	4	3	2	1	0
r/w	r/w	r/w	r/w	r/w	r/w	r/w	r/w	r/w	r/w	r/w	r/w	r/w	r/w	r/w	r/w

Bits	HEX	Meaning (binary)
0, 1	0003	00=°C, 01=°F, 10=K
2, 3	000C	Ext press unit, 00=psia, 01=bara, 10=kpa
4	0010	Field cal type, 0=1 gas (offset), 1=2 gas
5	0020	Field cal type 2, 0=1 gas (offset), 1=2 gas
6	0040	Field cal type 3, 0=1 gas (offset), 1=2 gas
7	0080	Date format 0=dd/mm/yy, 1=mm/dd/yy
11, 12, 13	3800	Ext Sensor Parameter (000=none, 001=dewp, 010=temp, 011=press, 100=other)
14, 15	C000	SPARE

Register Type E: Calibration Table Setting

15	14	13	12	11	10	9	8	7	6	5	4	3	2	1	0
r/w	r/w	r/w	r/w	r/w	r/w	r/w	r/w	r/w	r/w	r/w	r/w	r/w	r/w	r/w	r/w

Bits	HEX	Meaning (binary)
0	0001	Phase Control Input, 0–Internal, 1–External (mA Input)
1, 2	0006	Calibration Table, 0=Table 1, 1=Table 2, 2=Table 3

Register F: -2000.0...+2000.0

15	14	13	12	11	10	9	8	7	6	5	4	3	2	1	0
r/w	r/w	r/w	r/w	r/w	r/w	r/w	r/w	r/w	r/w	r/w	r/w	r/w	r/w	r/w	r/w

Range = 0...4000 represents -2000.0...+2000.0

Conversion: (RegValue – 20000)/10.0

For external sensor values

Dewpoint: -100/+20 °C, 148.0/68.0 °F, 173.0/293.0 K

Temp: -50.0/+100.0 °C, -58.0/+212.0 °F, 223.0/373.0 K

Pressure: 0.0/44.1 psia, 0.0/3.0 barA, 0.0/304.0 kpa

Register Type G: -200.00...+200.00

15	14	13	12	11	10	9	8	7	6	5	4	3	2	1	0
r/w	r/w	r/w	r/w	r/w	r/w	r/w	r/w	r/w	r/w	r/w	r/w	r/w	r/w	r/w	r/w

Range = 0...40000 represents -200.00...+200.00

Conversion: (RegValue – 20000)/100.00

Register Type I – Status/Error

15	14	13	12	11	10	9	8	7	6	5	4	3	2	1	0
r/w	r/w	r/w	r/w	r/w	r/w	r/w	r/w	r/w	r/w	r/w	r/w	r/w	r/w	r/w	r/w

Bit	HEX	Meaning	Namur LED
0	0001	Displays O ₂ HSR or O ₂ depending on setting (system)	N/A
1	0002	%Gas out of range (beyond calibration range, e.g. 0...25 %)	N/A
2	0004	Low Alarm ON	YELLOW 1 ON
3	0008	High Alarm ON	YELLOW 2 ON
4	0010	Ext Phase Control i/p signal error (input < 3.2mA or >21.4mA)	RED FLASH (priority2)
5	0020	Ext sens signal error (input < 3.2mA or >21.4mA)	RED FLASH (priority2)
6	0040	Cell T not stable (not within +/-0.15 °C of setpoint for continuous period 15 minutes)	RED ON (priority 1)
7	0080	Cell T sensor error (cell tempr measures <-50 or >80 °C)	RED ON (priority 1)
8	0100	N/A	N/A
9	0200	Thermal Conductivity sensor error (Vcomp <=1 or >8191)	RED ON (priority 1)
10	0400	PCB tempr too high (PCB tempr > Cell tempr setpoint)	RED ON (priority 1)
11	0800	Phase 1 Active	N/A
12	1000	Phase 2 Active	N/A
13	2000	Phase 3 Active	N/A
14	4000	Instrument is BLIND version (system)	N/A
15	8000	N/A	N/A

Register Type J

15	14	13	12	11	10	9	8	7	6	5	4	3	2	1	0
r/w	r/w	r/w	r/w	r/w	r/w	r/w	r/w	r/w	r/w	r/w	r/w	r/w	r/w	r/w	r/w



For reading each 8 bits represents a RTC value. For setting only the Lower 8 bits are used for each RTC value.

Register Type K: -32767...+32767

15	14	13	12	11	10	9	8	7	6	5	4	3	2	1	0
r/w	r/w	r/w	r/w	r/w	r/w	r/w	r/w	r/w	r/w	r/w	r/w	r/w	r/w	r/w	r/w

Range = 0...65535 represents values

Conversion: (RegValue – 32767)

Register Type L: Alarm Configuration

15	14	13	12	11	10	9	8	7	6	5	4	3	2	1	0
r/w	r/w	r/w	r/w	r/w	r/w	r/w	r/w	r/w	r/w	r/w	r/w	r/w	r/w	r/w	r/w

Bits	HEX	Meaning
0, 1	0003	Phase 1, Alarm 1 type – 00=OFF, 01=LOW, 10=HIGH
2, 3	000C	Phase 2, Alarm 1 type – 00=OFF, 01=LOW, 10=HIGH
4, 5	0030	Phase 3, Alarm 1 type – 00=OFF, 01=LOW, 10=HIGH
6, 7	00C0	Phase 1, Alarm 2 type – 00=OFF, 01=LOW, 10=HIGH
8, 9	0300	Phase 2, Alarm 2 type – 00=OFF, 01=LOW, 10=HIGH
10, 11	0C00	Phase 3, Alarm 2 type – 00=OFF, 01=LOW, 10=HIGH

Appendix F

Hazardous Area Certification

Appendix F Hazardous Area Certification

The XTC601 Binary Gas Analyzer is certified compliant to the ATEX Directive (2014/34/EU), the IECEx scheme and SI 2016 No. 1107 UKCA product marking scheme for use within Zone 1 & 2 Hazardous Areas and has been assessed as being so by CML Bv Netherlands (Notified Body 2776) and EUROFINS CML UK (Approved Body 2503).

The XTC601 Binary Gas Analyzer is certified compliant to the applicable North American Standards (USA and Canada) for use within Class I, Division 1 and Class I, Zone 1 Hazardous Locations and has been assessed as being so by QPS Evaluation Services Inc.

F.1 Product Standards

This product conforms to the Standards:

BS/EN60079-0:2018	CSA C22.2 No. 60079-1-16
BS/EN60079-1:2014	CSA C22.2 No. 61010-1-12
BS/EN60079-31:2014	ANSI/UL 60079-0 7th ed.
IEC60079-0:2017	ANSI/UL 60079-1 7th ed.
IEC60079-1:2014	ANSI/UL 61010-1, 3rd ed.
IEC60079-31:2013	FM 3600-2018
CSA C22.2 No. 30-1986	FM 3615-2018
CSA C22.2 No. 60079-0-19	FM 3810-2018

F.2 Product Standards

This product is attributed with the product certification codes:

ATEX, UKCA & IECEx	North American:
II 2 GD Ex d IIB+H2 T6 Gb	Class I, Division 1, Groups B, C and D, T6
Ex tb IIIC 85 °C Db IP66	Class I, Zone 1, AEx db IIB+H2 T6 Gb
	Ex db IIB+H2 T6 Gb
Silicone: Ta = -40 °C...+60 °C	Silicone: Ta = -40 °C...+50 °C
Viton: Ta = -15 °C...+60 °C	Viton: Ta = -15 °C...+50 °C
Ekraz: Ta = 10 °C...+60 °C	Ekraz: Ta = 10 °C...+50 °C

F.3 Global Certificates/Approvals

ATEX	CML 20ATEX1038X
IECEX	IECEX CML 20.0018X
UKCA	CML UKEX21.1048X
cQPSus	LR1507-6

These certificates can be viewed or downloaded from our websites at:
www.processsensing.com & www.michell.com

F.4 Special Conditions

1. Cable entry holes shall be fitted with either an appropriately certified cable gland or appropriate certified blanking element. These shall provide and maintain a minimum enclosure ingress protection of IP66.
2. The maximum pressure associated with the process medium in the internal pipes shall be limited to 4 bar.
3. The maximum temperature associated with the process medium shall be limited to 60 °C.
4. The flameproof joints of the flame arrestors & breather are not intended to be repaired.

F.5 Maintenance and Installation

The XTC601-EX must only be installed by suitably qualified personnel and in accordance with the instructions provided and the terms of the applicable product certificates.

Maintenance and servicing of the product must only be carried out by suitably trained personnel or returned to an approved Michell Instruments Service Center.

Flame paths are not intended to be repaired.

Appendix G

Quality, Recycling, Compliance & Warranty Information

Appendix G Quality, Recycling, Compliance & Warranty Information

Michell Instruments is dedicated to complying to all relevant legislation and directives. Full information can be found on our website at:

www.michell.com/compliance

This page contains information on the following directives:

- Anti-Facilitation of Tax Evasion Policy
- ATEX Directive
- Calibration Facilities
- Conflict Minerals
- FCC Statement
- Manufacturing Quality
- Modern Slavery Statement
- Pressure Equipment Directive
- REACH
- RoHS3
- WEEE2
- Recycling Policy
- Warranty and Returns

This information is also available in pdf format.

Appendix H

Analyzer Return Document & Decontamination Declaration

Appendix H Analyzer Return Document & Decontamination Declaration

Decontamination Certificate

IMPORTANT NOTE: Please complete this form prior to this instrument, or any components, leaving your site and being returned to us, or, where applicable, prior to any work being carried out by a Michell engineer at your site.

Instrument			Serial Number	
Warranty Repair?	YES	NO	Original PO #	
Company Name			Contact Name	
Address				
Telephone #			E-mail address	
Reason for Return /Description of Fault:				
Has this equipment been exposed (internally or externally) to any of the following? Please circle (YES/NO) as applicable and provide details below				
Biohazards			YES	NO
Biological agents			YES	NO
Hazardous chemicals			YES	NO
Radioactive substances			YES	NO
Other hazards			YES	NO
Please provide details of any hazardous materials used with this equipment as indicated above (use continuation sheet if necessary)				
Your method of cleaning/decontamination				
Has the equipment been cleaned and decontaminated?			YES	NOT NECESSARY
Michell Instruments will not accept instruments that have been exposed to toxins, radio-activity or bio-hazardous materials. For most applications involving solvents, acidic, basic, flammable or toxic gases a simple purge with dry gas (dew point <-30°C) over 24 hours should be sufficient to decontaminate the unit prior to return. Work will not be carried out on any unit that does not have a completed decontamination declaration.				
Decontamination Declaration				
I declare that the information above is true and complete to the best of my knowledge, and it is safe for Michell personnel to service or repair the returned instrument.				
Name (Print)			Position	
Signature			Date	





Instrument Expert Original
factory packaging
www.keruiyiqi.cn

www.ProcessSensing.com



<http://www.michell.com>