

# XTC601 for Monitoring Hydrogen Cooled Generators

## Thermal Conductivity Technology

A robust, linear and stable thermal conductivity analyzer for measuring the binary gas mixes present during the operation and maintenance of hydrogen cooled electricity generators. The primary measurement is hydrogen (H<sub>2</sub>) purity to monitor air leaking into the system. The second measurement is monitoring hydrogen in carbon dioxide (CO<sub>2</sub>) during system purging, and finally CO<sub>2</sub>/air during maintenance. The sensor and HMI are in one compact case that is under 10 kg (22 lb). The analyzer is suitable for hazardous areas and uses non-depleting sensor technology for minimal cost of ownership.



### Highlights

- Suitable for use in ATEX, IECEx, UKCA, TR CU Ex & cQPSus
- Monitors all three phases of hydrogen cooled generators: normal running, purging and maintenance
- Remotely change the measurement phase to match your maintenance schedule
- Phase indication via 4...20 mA output
- Touch-screen display allows calibration or adjustment without the need for a hot works permit
- Compact and rugged design with an EExd enclosure
- IP66 rated enclosure so no chance of water or dust ingress
- Low cost of ownership due to minimal maintenance

### Other applications for the XTC601

- Product quality in air separation plants
- Syngas production
- Helium recovery
- Fuel cell research
- Product quality such as air in argon for double glazing



## Michell XTC601 for hydrogen cooled generators

The XTC601 for Hydrogen Cooled Generators is a binary gas analyzer which has been designed specifically for monitoring the purity and scheduled maintenance processes of hydrogen cooled generators. Using thermal conductivity with high quality thermistors, the sensor is reliable and highly stable. The analyzer is housed in an explosion-proof case and is rated for use in hazardous areas.

### Features

#### Non-Depleting Technology

The non-depleting sensor technology with no moving parts means that there is no regular replacement of cells, this greatly reducing maintenance time and the cost of ownership

#### Easy Installation with Local Display

The XTC601 for Hydrogen Cooled Generators is housed in a robust casing, allowing the analyzer to be placed at the point of measurement.

The closer the analyzer can be installed to the sample point, the better. The benefits of this include faster overall speed of response (for safety), less sample line or cabling (saves costs), and greater choice of installation points (flexibility). Having a local display allows for maintenance and diagnostics to be performed directly rather than in a control room.

#### Internal or External Phase Control

There are three methods of choosing the phase. The first is internally via the HMI of the instruments, the second is through the Modbus interface and the third is via 4...20 mA input.

The second mA output is utilized as a phase indication.

#### External Sensor Input

The unit has the facility to accept a 4...20 mA signal from an external source such as dew-point sensor, temperature probe or user-defined sensor, and display it on the screen. This saves the cost of buying and installing an external display for another parameter that only requires occasional visual inspection.

### Technology

#### Thermal Conductivity Sensor

Thermal conductivity is a property of all gases. Hydrogen is used as a cooling agent in electricity generators because it has a very high thermal conductivity, and is able to quickly draw off the heat created by the power load of the coils and windings in the generator.

The sensor in the XTC601 for Hydrogen Cooled Generators utilizes thermal conductivity technology to accurately determine the purity of the hydrogen in the cooling loop.

#### Measurement Principle

The measuring principle is via matched thermistors in a Wheatstone Bridge configuration. One thermistor is in the sample cell and the other is in either a sealed or flowing reference chamber. The whole assembly is heated to +50°C (+122°F) to ensure an iso-thermal environment. This provides an accurate and stable platform for measuring the target gas concentration.

### Phase functions

The diagram below summarizes how the different phases are normally used in hydrogen cooled generator applications so that maintenance can be carried out.

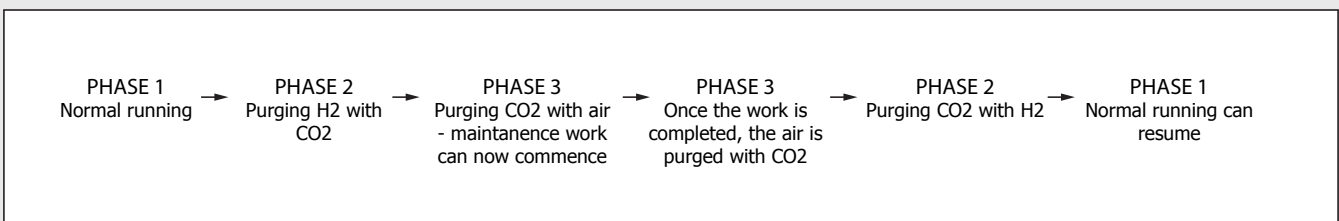

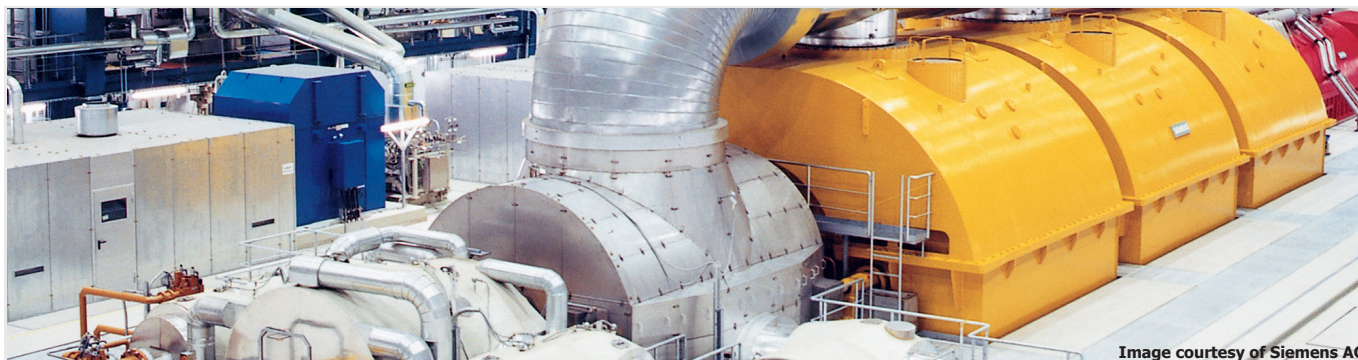
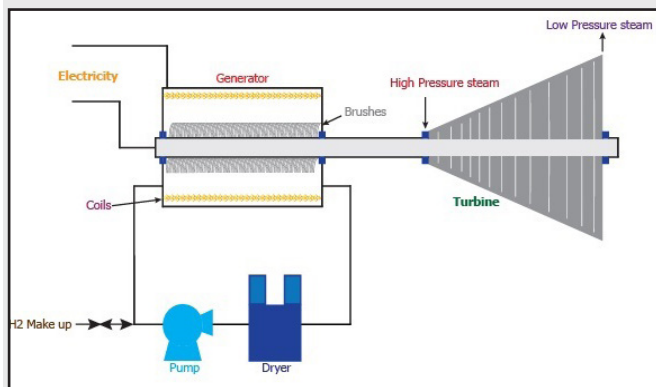

Image courtesy of Siemens AG

## The three phases of hydrogen cooled generator applications

### Hydrogen cooled generator applications

Most conventional power plants use steam from process boilers that are heated by the combustion of coal, natural or synthetic gas or biomass to run generators to create electricity. High pressure steam is injected into a turbine causing the turbine shaft to spin at a high rate creating mechanical energy. The shaft is connected to an electric generator, which converts the mechanical energy into electricity via metal brushes (on the shaft) passing over stationary coils. This process also generates considerable heat. Hydrogen is used as a coolant, as it has two properties that are beneficial in this process it has very high thermal conductivity (to draw the heat away) and very low viscosity (to reduce the wind resistance on the brushes). If a 900MW generator has a reduction in hydrogen purity from 99% to 96%, an increased loss of 670KW (or enough power for around 1,000 households) will result due to increased windage and decreased cooling efficiency.



Typical schematic of a hydrogen cooled generator

### Phase 1 – General running H<sub>2</sub> in Air

During normal operation the analyzer is monitoring air in hydrogen (80/90...100% H<sub>2</sub>) for safety and efficiency.

Back. Gas: Air	CONTROL	INTERNAL
98.70 % H <sub>2</sub>	PHASE	H <sub>2</sub> /AIR
H <sub>2</sub> in Air phase		

### Phase 2 – Purging H<sub>2</sub> in CO<sub>2</sub>

CONTROL	EXTERNAL
PHASE	H <sub>2</sub> /CO <sub>2</sub>

Hydrogen is very flammable and is explosive in concentrations from 4% to 75% in air, so when routine maintenance is carried out, the plant can't simply turn off the hydrogen and open the turbine due to the explosive potential of the hydrogen/air mixture that would result.

Instead, the turbine is purged with carbon dioxide to remove the hydrogen. When the carbon dioxide is at 100% (and therefore 0% hydrogen), it is safe to allow air into the turbines.

### Phase 3 – Purging CO<sub>2</sub> in Air

CONTROL	EXTERNAL
PHASE	CO <sub>2</sub> /AIR

Before the units can be opened the carbon dioxide, which is an asphyxiant, must be purged with air. Once the unit reads 100% air, it is safe to break the seals and commence maintenance.

After maintenance is complete, the purging cycles are reversed to end up with pure hydrogen in the system and the turbine can be started back up.

The XTC601 for Hydrogen Cooled Generators can monitor all of the phases in a compact analyzer with an integrated HMI.

## Oxygen & Binary Gas Analyzers

# Technical Specifications

Performance			
Phase	Phase 1 – H <sub>2</sub> in Air	Phase 2 – H <sub>2</sub> in CO <sub>2</sub>	Phase 3 – CO <sub>2</sub> in Air
Measurement Range	80...100% or 90...100%	0...100%	0...100%
Display resolution	0.01%	0.1%	1%
Response time (T90)	< 20 seconds	< 20 seconds	< 50 seconds
Recommended calibration	Monthly	Prior to use	Annually
Measurement technology	Thermal Conductivity sensor		
Gas requirements	Non-condensing sample with particles <3µm		
Display type	Backlit LCD		
Repeatability	±0.2% of range		
Linearity	±1% range		
Sample flow rate	100...600 ml/min		
Sample flow effect (calibrated at 300 ml/min)	< 1% of range for flows: 100...600 ml/min		
Sample pressure	0...3 barg with atmospheric vent		
Sample temperature	0...+45 °C (0...113 °F) max		
Sample cell temperature	+50 °C (122 °F)		
Electrical Specifications			
Analog inputs	2 off 4...20 mA inputs One to control phase selection One for an external sensor that can be displayed on the screen		
Analog outputs	2 off 4...20 mA outputs: mA 1 = Concentration mA 2 = Phase indication		
Alarms	2 off single pole changeover (SPCO) relays for concentration (250 V, 5 A max)		
Digital communications	Modbus RTU over RS485		
Power supply	24 V DC, 1.5 A max		

Operating Conditions	
Ambient temperature	-15...+55 °C (5...+131 °F)
Mechanical Specifications	
Warm up & stabilization time	< 30 minutes
Dimensions	234 x 234 x 172 mm (9.21" x 9.21" x 6.77") (w x d x h)
Weight	9.7 kg (21.38 lb)
Wetted materials	316 stainless steel, borosilicate glass, platinum, Viton
O-Ring materials	Viton
Gas connection	1/8" NPT
Ingress protection	IP66, NEMA 4
Hazardous Area Classification	
ATEX/UKCA	II 2GD Ex d IIB+H2 T6 Gb Ex tb IIIC T85 °C Db IP66 Ta = -15 °C...+55 °C
IECEx	Ex d IIB+H2 T6 Gb Ex tb IIIC T85 °C Db IP66 Ta = -15 °C...+55 °C
cQPSus	Class I, Division 1, Groups B C D, T6
TR CU Ex	1Ex d IIB+H2 T6 Gb

Note: Please see the main XTC Series Datasheet for other gases and applications.

## Dimensions

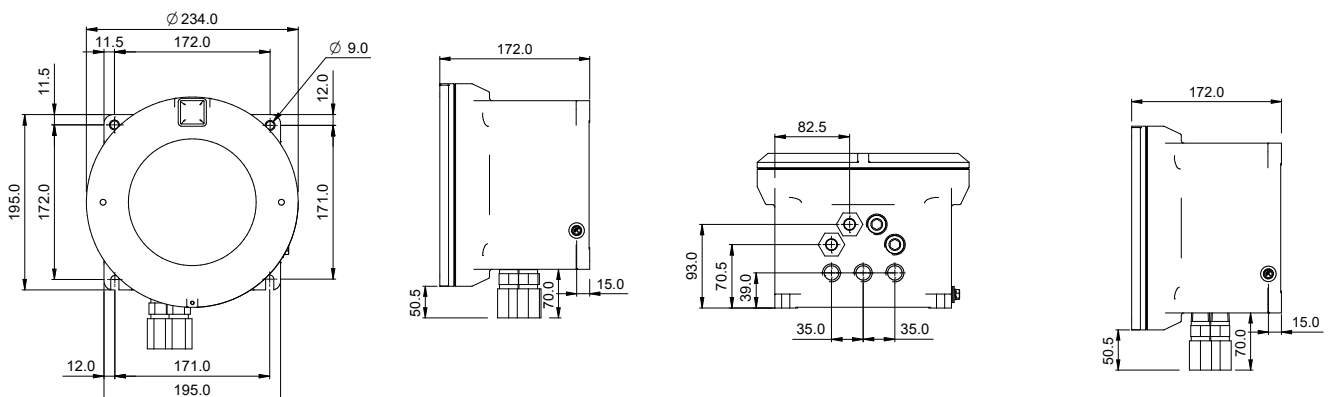

Michell Instruments Ltd, Rotronic Instruments Corp. 135 Engineers Road, Suite 150, Hauppauge NY 11788  
Tel: 631 427 3898, Email: [us.info@michell.com](mailto:us.info@michell.com), Web: [www.michell.com/us](http://www.michell.com/us)

Michell Instruments adopts a continuous development programme which sometimes necessitates specification changes without notice.  
Issue no: XTC601 for Hydrogen Cooled Generators\_97523\_V3.1\_US\_0921