

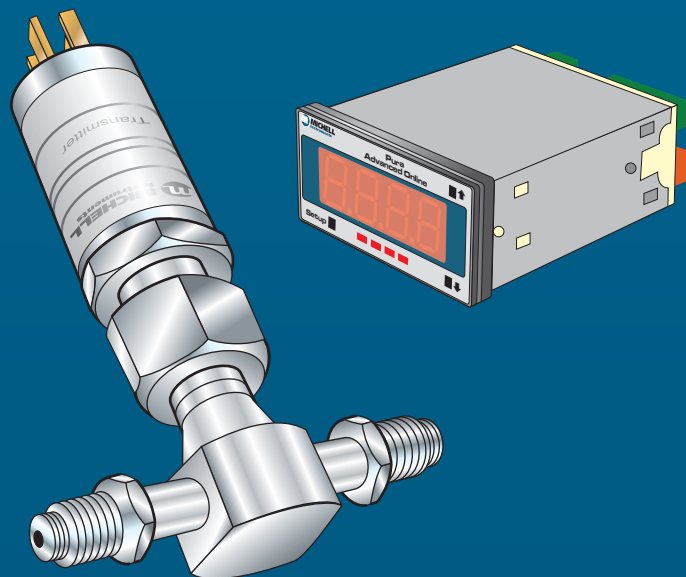

Pura Advanced Online Hygrometer User Manual



Please fill out the form(s) below for each instrument that has been purchased.

Use this information when contacting Michell Instruments for service purposes.

Product Name	
Order Code	
Serial Number	
Invoice Date	
Installation Location	
Tag Number	

Product Name	
Order Code	
Serial Number	
Invoice Date	
Installation Location	
Tag Number	

Product Name	
Order Code	
Serial Number	
Invoice Date	
Installation Location	
Tag Number	



Pura Advanced Online Hygrometer

For Michell Instruments' contact information please go to
www.michell.com

© 2022 Michell Instruments

This document is the property of Michell Instruments Ltd and may not be copied or otherwise reproduced, communicated in any way to third parties, nor stored in any Data Processing System without the express written authorization of Michell Instruments Ltd.

Contents

Safety	vi
Electrical Safety	vi
Pressure Safety	vi
Toxic Materials	vi
Repair and Maintenance	vi
Calibration	vi
Safety Conformity	vi
Abbreviations	vii
Warnings	vii
1 INTRODUCTION	1
1.1 Features	1
2 INSTALLATION	2
2.1 Unpacking the Instrument.....	2
2.1.1 Unpacking Pura Advanced Online Hygrometer	2
2.1.2 Unpacking Pura SEN (transmitter, no block version)	3
2.1.3 Unpacking Pura OEM-single bag, PRM-double bag versions	4
2.1.4 Unpacking Monitor	4
2.2 Pura Advanced Online Components.....	5
2.3 Pura SEN	6
2.4 Pura OEM, PRM	6
2.5 Monitor.....	7
2.6 Monitor Panel Layout	7
2.7 Transmitter Mounting	8
2.7.1 Sensor Block Connection (Recommended Method)	8
2.7.2 Direct Pipeline Connection	9
2.7.3 Pura OEM & PRM Connection	10
2.8 Sensor Cables	11
2.8.1 Self-Assembly	11
2.8.2 Cable Selection for Self-Assembled Cables.....	11
2.8.3 Wiring Connection Between the Transmitter and the Monitor.....	12
2.9 Mounting the Monitor	13
2.10 Electrical Connections	14
2.10.1 High Voltage Power Supply Input	14
2.10.2 Low Voltage Power Supply Input (Optional)	15
2.11 Pressure Transducer Connection (Optional)	15
2.12 Transmitter Connections.....	16
3 OPERATION	17
3.1 Set-Up Security Feature	17
3.1.1 Selecting the Engineering Units.....	18
3.1.2 Configuring the Alarms	18
3.1.3 Hysteresis, Make/Break Delay & Delay Type	19
3.1.4 Analog Output Scaling	20
3.1.5 Display Brightness Adjustment.....	20
3.2 Pressure Compensation.....	21
3.3 Using a Pressure Transducer	21
3.3.1 Manual Pressure Input Calibration	21
3.3.2 Automatic Pressure Input Calibration	22
3.4 Using a Fixed Pressure Input in Single Channel Mode.....	22

4	MAINTENANCE	23
4.1	Maintenance and Calibration	23
4.2	Fault Conditions	23
5	MEASUREMENT GUIDE	24
5.1	Sampling Considerations	24
5.2	Sampling Hints	27

Figures

Figure 1	Unpacking – Monitor and Pura SEN, no block version	2
Figure 2	Unpacking – Monitor and Pura OEM / PRM	3
Figure 3	Unpacking – Pura OEM & PRM – Single / Double Bag	4
Figure 4	Unpacking – Monitor	4
Figure 5	Components	5
Figure 6	Pura SEN	6
Figure 7	Pura OEM, PRM	6
Figure 8	Control Layout and Functions	7
Figure 9	Sensor Block Connection	8
Figure 10	Connector Terminal Block Removal	11
Figure 11	Cable Assembly	11
Figure 12	Cable Connections	12
Figure 13	Connector Installation	12
Figure 14	Mounting the Monitor	13
Figure 15	High Voltage Power Supply Connections	14
Figure 16	Low Voltage Power Supply Connections	15
Figure 17	Electrical Connection Detail	15
Figure 18	Transmitter Connections	16
Figure 19	Location of the Lockout switches	17
Figure 20	Installation Location	25
Figure 21	Installation Location	25
Figure 22	Material Permeability Comparison	27
Figure 23	Dead volume	28
Figure 24	Pura SEN	32
Figure 26	Monitor Dimensions	32
Figure 25	Pura PRM & OEM	32

Tables

Table 1	Cable Connections	12
Table 2	Operation Access Levels	17
Table 3	Engineering Unit Selection	18

Appendices

Appendix A	Technical Specifications	31
Appendix B	Setup Codes	34
Appendix C	Quality, Recycling & Warranty Information	37
Appendix D	Return Document & Decontamination Declaration	39

Safety

The manufacturer has designed this equipment to be safe when operated using the procedures detailed in this manual. The user must not use this equipment for any other purpose than that stated. Do not apply values greater than the maximum value stated.

This manual contains operating and safety instructions, which must be followed to ensure the safe operation and to maintain the equipment in a safe condition. The safety instructions are either warnings or cautions issued to protect the user and the equipment from injury or damage. Use competent personnel using good engineering practice for all procedures in this manual.

Electrical Safety

The instrument is designed to be completely safe when used with options and accessories supplied by the manufacturer for use with the instrument.

Pressure Safety

DO NOT permit pressures greater than the safe working pressure to be applied to the instrument. The specified safe working pressure is 24 MPa (240 barg / 3480 psig).

Toxic Materials

The use of hazardous materials in the construction of this instrument has been minimized. During normal operation it is not possible for the user to come into contact with any hazardous substance which might be employed in the construction of the instrument. Care should, however, be exercised during maintenance and the disposal of certain parts.

Repair and Maintenance

The instrument must be maintained either by the manufacturer or an accredited service agent. For contact information visit the website at www.michell.com

Calibration

Periodic re-calibration is recommended in order to maintain the highest quality of measurement in your application. Michell Instruments recommends that you have your Pura transmitter re-calibrated annually unless it is used in a mission-critical application or in a contaminated environment, in which case the calibration interval should be reduced accordingly.

Michell Instruments can offer a variety of re-calibration and exchange transmitter schemes to suit your specific needs. A local representative will be pleased to provide detailed, custom advice.

Safety Conformity

This product meets the essential protection requirements of the relevant EU & UKCA directives. Further details of applied standards may be found in Appendix C.

Abbreviations

The following abbreviations are used in this manual:

AC	alternating current
atm	pressure unit (atmosphere)
barg	pressure unit (=100 kP or 0.987 atm)
°C	degrees Celsius
°F	degrees Fahrenheit
DC	direct current
dp	dew point
ft	foot (feet)
g	gram(s)
Hz	Hertz
"	inch(es)
lb	pound
l/min	liters per minute
m	meter(s)
µm	micro-meter
mA	milliampere
max	maximum
min	minute(s)
MPa	megapascal (Pascals x10 ⁶)
NI/min	normal liters per minute
Nm	Newton meter
ppm _v	parts per million (by volume)
rh	relative humidity
scfh	standard cubic feet per hour
V	Volts
Ω	Ohms

Warnings

The following general warning is applicable to this instrument. It is repeated in the text in the appropriate locations.



Where this hazard warning symbol appears in the following sections it is used to indicate areas where potentially hazardous operations need to be carried out.



Where this symbol appears in the following sections it is used to indicate areas of potential risk of electric shock.

1 INTRODUCTION

The Pura Advanced Online Hygrometer is an instrument designed for the continuous online measurement of moisture content in non-corrosive gases, over an operational range of -120 °C...-40 °C (-184 °F...-40 °F) dew point and equivalent units (see Appendix A, Technical Specifications).

The system comprises a programmable monitor configured to accept a unique Michell Mnet data string from the Pura transmitter. The zero and span of the monitor are set to cover the dew-point range -120 °C...-40 °Cdp (-184 °F...-40 °Fdp) at operating pressures up to 24 MPa (240 barg/3480 psig).

Two alarm outputs are provided for connection to external systems which are user-configurable both in terms of setpoint and operating mode. Current output is standard and factory set at 4...20 mA (or optionally set at 0...20 mA or 0...10 V).

The monitor has a pressure input channel for any industry standard 2-wire pressure transmitter. In addition to providing a pressure measurement, the pressure signal can be used to provide real-time pressure compensation on the primary channel when displaying ppm values. The customer can also set a fixed pressure compensation value. The pressure input only affects the ppm_v or ppb_v units. For dew point, the displayed value is a pressure dew point.

1.1 Features

The Pura Advanced Online Hygrometer is simple to use and install, and can be configured to meet specific needs.

- ¼" male VCR process connections for PRM and OEM version
½" male VCR process connection for Pura SEN version
- Dew-point, ppm_v or ppb_v moisture content
- Michell Mnet – sensor digital string signal
- Sensor block compliant with clean room standards
- Measurement range -120 °C...-40 °Cdp (-184 °F...-40 °Fdp)
- Up to ±1 °Cdp accuracy
- Calibration certificate (NPL, NIST)

2 INSTALLATION



It is essential that the connection of electrical and gas supplies to this instrument be undertaken by competent personnel.

2.1 Unpacking the Instrument

2.1.1 Unpacking Pura Advanced Online Hygrometer

The Pura Advanced Hygrometer instrument and accessories are packed in a box and the method of unpacking is shown as follows:

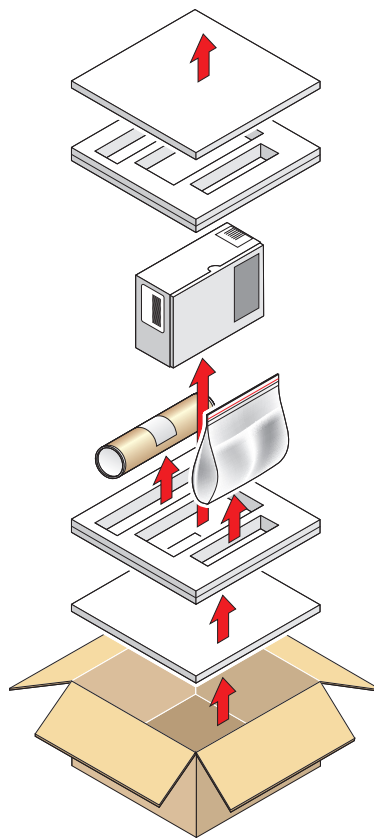

Figure 1 Unpacking – Monitor and Pura SEN, no block version

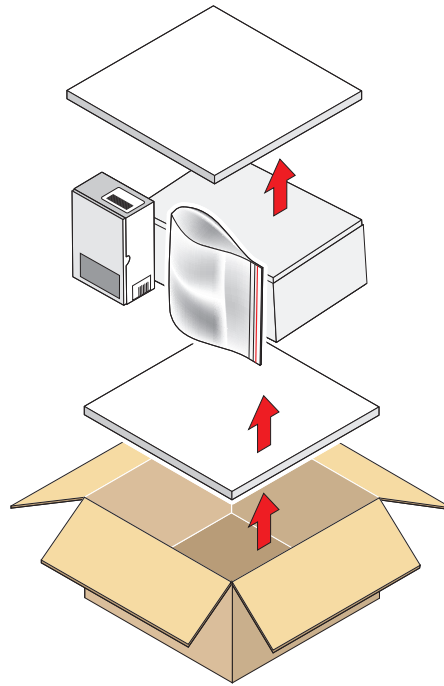

Figure 2 *Unpacking – Monitor and Pura OEM / PRM*

2.1.2 Unpacking Pura SEN (transmitter, no block version)

Unpack the dew-point transmitter from the rectangular cardboard box.

NOTE: The transmitter sensing element is protected while in transit by a red cover containing a small desiccant capsule. This plastic item is not required for the operation of the transmitter.

NOTE: Keep the electrical connector in a safe place until the transmitter is ready for wiring.

2.1.3 Unpacking Pura OEM-single bag, PRM-double bag versions

Figure 3 *Unpacking – Pura OEM & PRM – Single / Double Bag*

2.1.4 Unpacking Monitor

The monitor (2) is packed, together with its fixing clamps (1) as shown below.

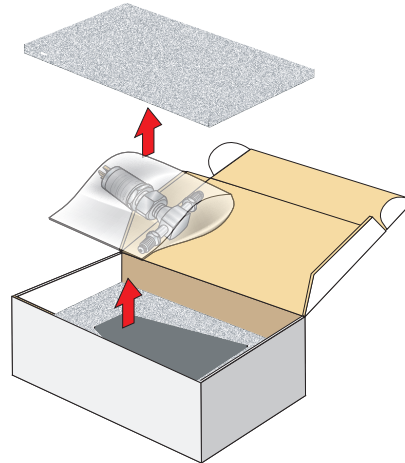
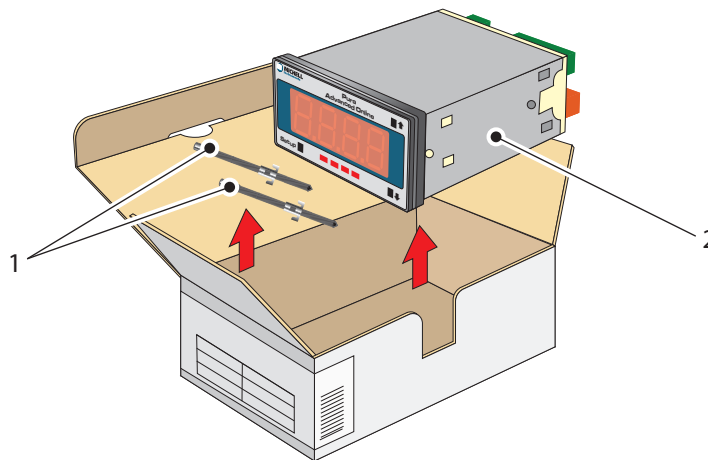

Figure 4 *Unpacking – Monitor*

2.2 Pura Advanced Online Components

On delivery, please check that all the following standard components are present in the packing box. Report any shortages immediately.

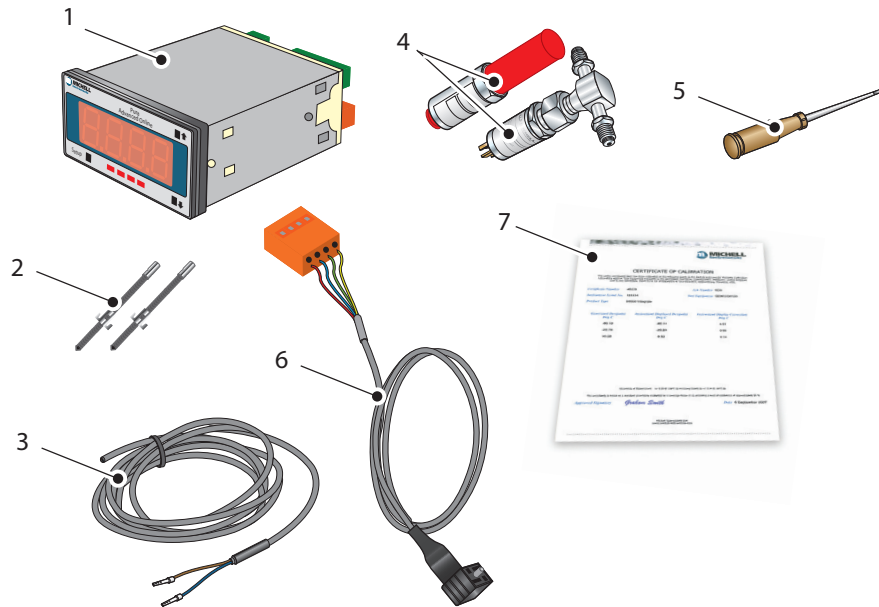

Figure 5 Components

1. PURA Monitor
2. Clamps
3. Sensor cable assembly
4. Pura Transmitter (SEN) OR
Pura Transmitter (OEM) or (PRM)
Leak test certificate included
5. Screwdriver
6. Power cable
7. Calibration certificate

2.3 Pura SEN

NOTE: For environmental and operating conditions, refer to Appendix A, Technical Specifications.

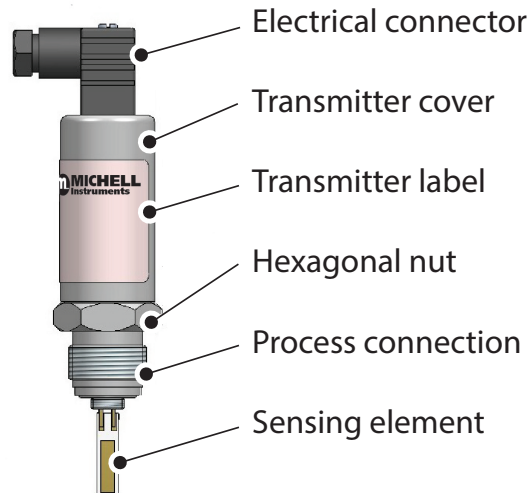
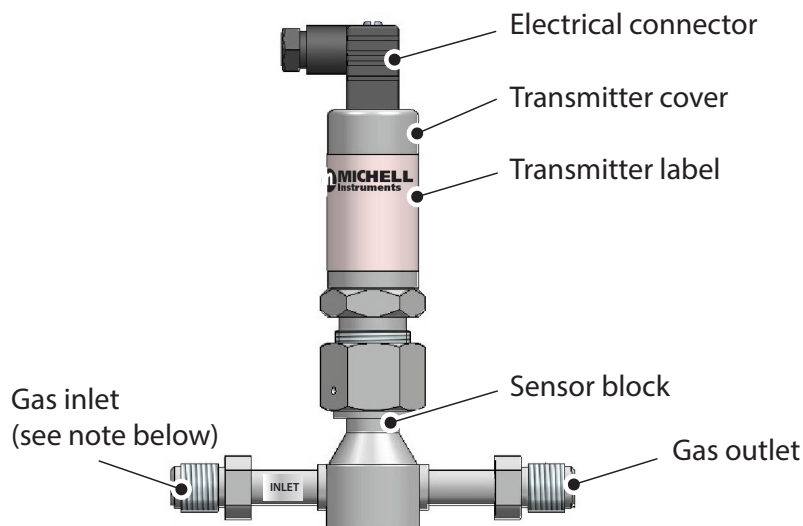

Figure 6 Pura SEN

2.4 Pura OEM, PRM

NOTE: For environmental and operating conditions, refer to Appendix A, Technical Specifications.

NOTE: OEM and PRM version transmitters are protected in transit by putting in a plastic bag filled with nitrogen. Pura OEM transmitter has single bag protection, Pura PRM transmitter has double bag protection.



NOTE: The Pura has a uni-directional connection and must be connected so the upstream flow is connected to the inlet port of the Pura block (marked with a silver label).

Figure 7 Pura OEM, PRM

2.5 Monitor

The instrument has a 5-digit display, set up on delivery to display a dew-point temperature range of -120 °C...-40 °Cdp (-40 °F...-184 °Fdp).

Dew-point temperature units are displayed by the last LED located to the far right of the display. On delivery, °Cdp is set up. If required, the units can be changed to °F. The method of configuring the unit for °F is described in Section 3.1.1.

Optionally, the instrument can be set up for parts per million ppm_v or parts per billion ppb_v. This option requires the hygrometer to be set up for ppm_v or ppb_v (see Section 3.1.1).

Four alarm indications are provided by four LEDs located on the bottom of the display. These are marked SP1, SP2, SP3, SP4. Access to the alarm relay contacts is provided on the rear panel. The connection for these alarm relay contacts is shown in *Figure 18*. **NOTE: Every display is factory fitted with 2 alarm relays as standard.**

Refer to Section 3, Operation, for information on how to configure the alarms.

2.6 Monitor Panel Layout

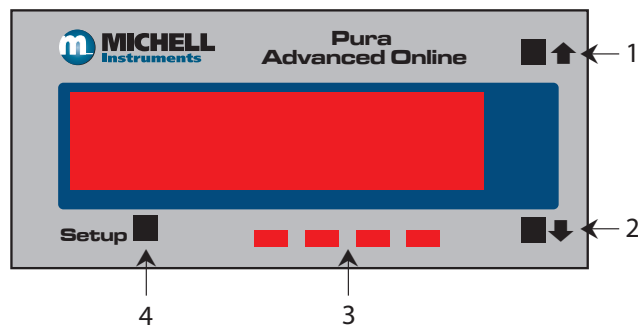

Item	Function
1	Increases the value of the displayed parameter; navigates through each displayed parameter
2	Decreases the value of the displayed parameter; navigates through each displayed parameter
3	LED annunciations for Alarm Setpoints 1...4
4	Saves programming settings, moves between programming steps

Figure 8 Control Layout and Functions

2.7 Transmitter Mounting

2.7.1 Sensor Block Connection (Recommended Method)



The following procedure must be carried out by a qualified installation engineer.



WARNING: Under no circumstances should the sensing element be handled with the fingers.

To mount the transmitter into the sensor block, proceed as follows – refer to *Figure 9*.

1. Remove the red protective cover (2) from the tip of the transmitter (1).
2. Fit the 1/2" VCR gasket (3) over the threaded part of the transmitter body.
3. Screw the transmitter (1) into the sensor block (4) and tighten the gas line nut 1/8 (one eighth) of a turn using a second spanner/wrench. **NOTE: Use the flats of the hexagonal nut and not the sensor body.**
4. Fit the transmitter cable/connector assembly to the plug located on the base of the transmitter and tighten the fixing screw (see *Figure 13*).

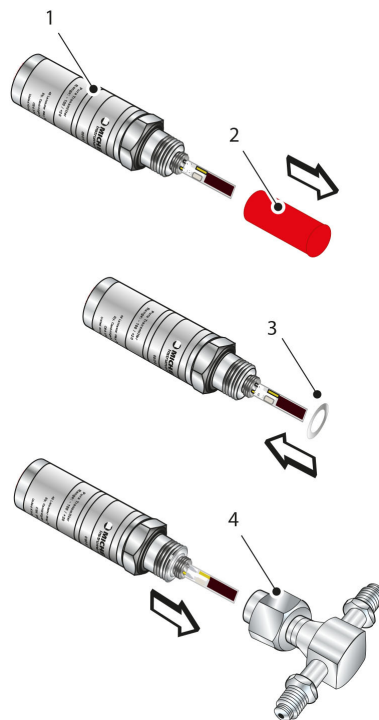

Figure 9 Sensor Block Connection

2.7.2 Direct Pipeline Connection

The transmitter may be directly mounted into a pipe or duct.



CAUTION: Do not mount the transmitter too close to the bottom of a bend where any condensate in the pipeline might collect and saturate the probe.

The pipe or duct will require a 1/2" VCR male process connection thread to match the transmitter body thread. For circular pipework, to ensure the integrity of a gas tight seal, a mounting flange will be required on the pipework in order to provide a flat surface to seal against.

Procedure



The following procedure must be carried out by competent personnel.



WARNING: Under no circumstances should the filter guard be handled with the fingers.

1. Ensure that the red protective cover has been removed from the tip of the transmitter.
2. After first checking that the pipeline has a wide enough bore to accept the transmitter's process connection screw the transmitter into the pipe. Tighten enough to obtain a gas tight seal. (Torque will depend upon the pipeline material.)

Michell Instruments recommends the use of Swagelok® retained gasket assemblies, containing silver plated, stainless steel 1/2" VCR gaskets, when connecting the Pura into a gas line.

NOTE: Do not overtighten or the thread on the pipework may be stripped.

2.7.3 Pura OEM & PRM Connection

The Pura OEM and PRM have been assembled and packaged within a Class 100 clean-room environment. To maintain this level of cleanliness the packaging should only be unpacked within the same, or cleaner, environment.

Michell Instruments recommends the use of Swagelok® retained gasket assemblies, containing silver plated, stainless steel ¼" VCR gaskets, when connecting the Pura into a gas line. The distance between the inlet and outlet gas connection ports is set at a pitch of 120 mm (4.7").



CAUTION: Over tightening the nuts can cause irrecoverable damage to the seals and seatings.

1. Install the sealing gasket onto the VCR connections on either the Pura or the connecting gas lines. Ensure that the Pura is installed into the gas line with reference to the gas flow direction and the inlet port, as indicated on the Pura body.
2. Tighten the female nut firmly, finger tight.
3. Hold the Pura transmitter stationary with a spanner/wrench and tighten the gas line nut 1/8 of a turn using a second spanner/wrench.
4. Repeat this operation on the remaining gas connection port.

2.8 Sensor Cables

2.8.1 Self-Assembly

For guidance on type of cable, refer to Section 2.8.2, Cable Selection for Self-Assembled Cables.

Assembly Instructions

1. Remove the screw from the rear of the DIN connector housing.
2. Lever the terminal block from the connector housing by inserting a small screwdriver in the notch on the front face of the terminal block.
3. Ensure the small sealing O-ring and washer are retained with the screw.

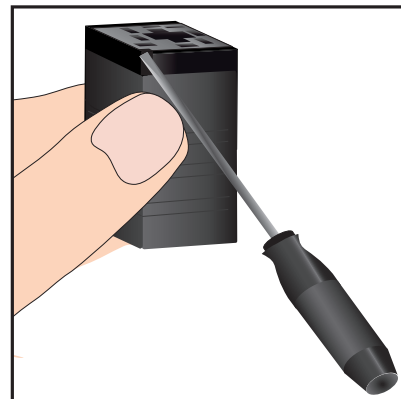
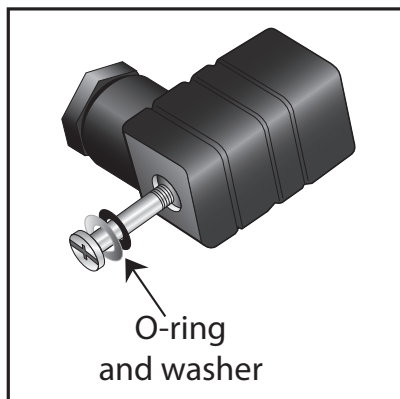

Figure 10 Connector Terminal Block Removal

4. Cable should be assembled according to Figure 11.

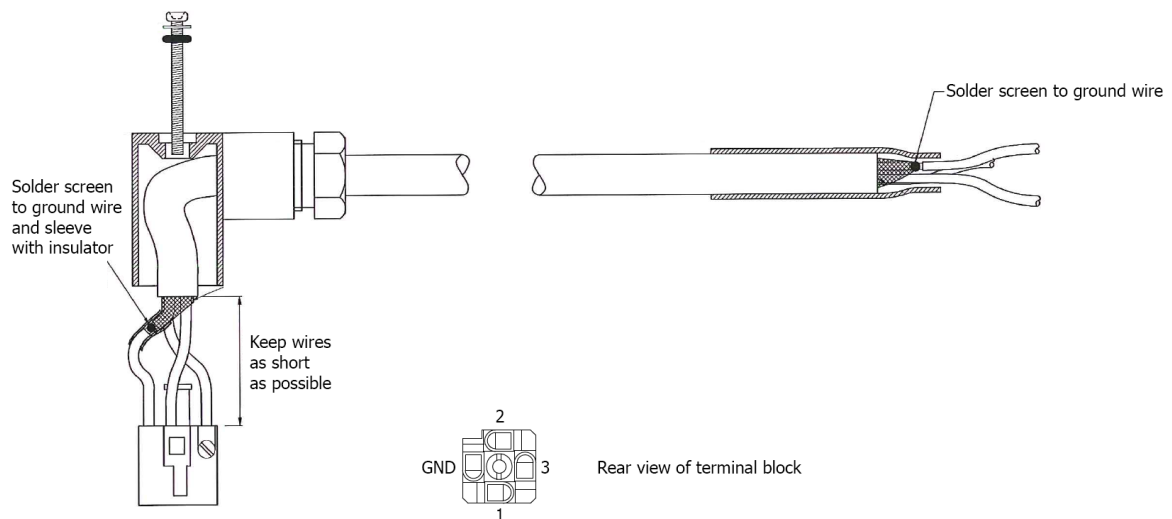

Figure 11 Cable Assembly

2.8.2 Cable Selection for Self-Assembled Cables

It is recommended to use 3-core screened cable. For short runs, a cable with individual conductor sizes of 24 AWG / 0.21 mm₂ would be a typical choice.

2.8.3 Wiring Connection Between the Transmitter and the Monitor

The diagram below shows the identity of the connector terminals.

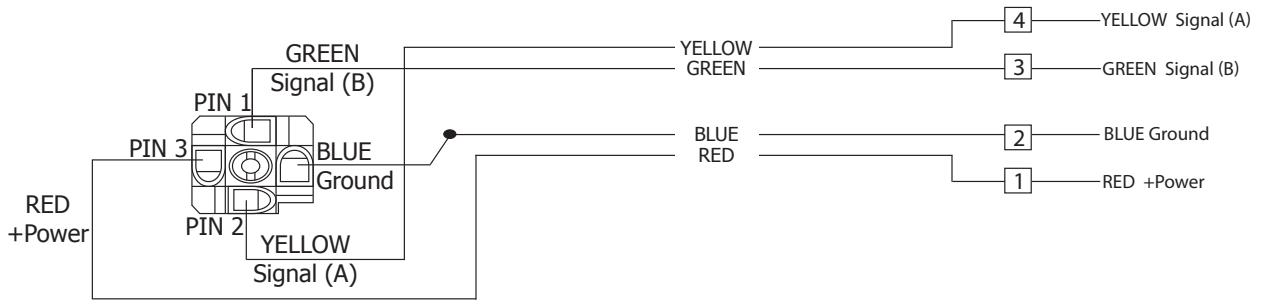

Figure 12 Cable Connections

The sensor cable connections are shown in the table below and in the figure above.

Connection	Red wire	Blue wire	Green wire	Yellow wire
Monitor	Pin 1	Pin 2	Pin 3	Pin 4
Transmitter	Pin 3	GND	Pin 1	Pin 2

Table 1 Cable Connections

When installing the connector, and to ensure that full ingress protection is achieved, the securing screw (with the O-ring and washer) must be tightened to a minimum torque setting of 3.4 Nm (2.5 ft-lbs). The sensor cable used must be a minimum diameter of 4.6 mm (0.2”).

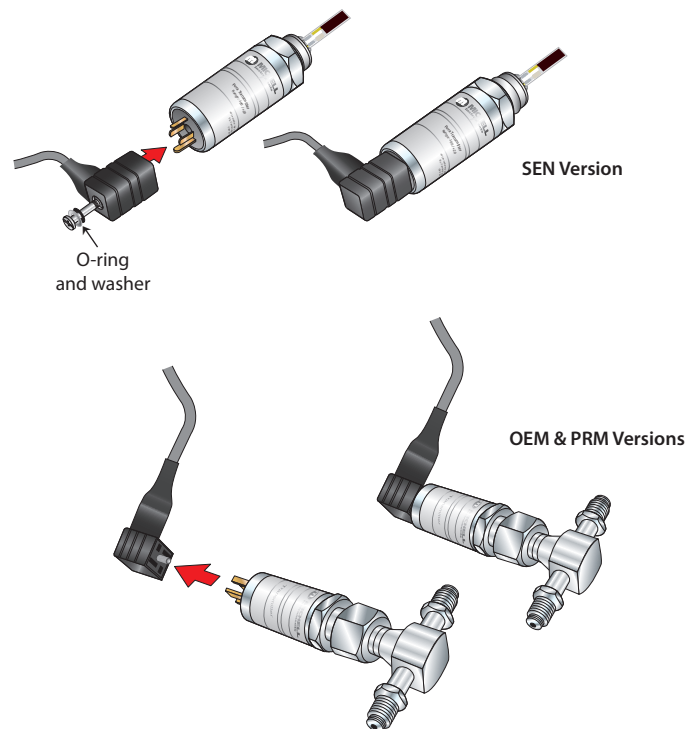

Figure 13 Connector Installation

2.9 Mounting the Monitor

The monitor is designed for panel mounting and requires a panel cut-out of 46 x 92 mm (1.8 x 3.6"). The recommended panel thickness is 2...5 mm (0.08...0.2").

To mount the unit, proceed as follows:

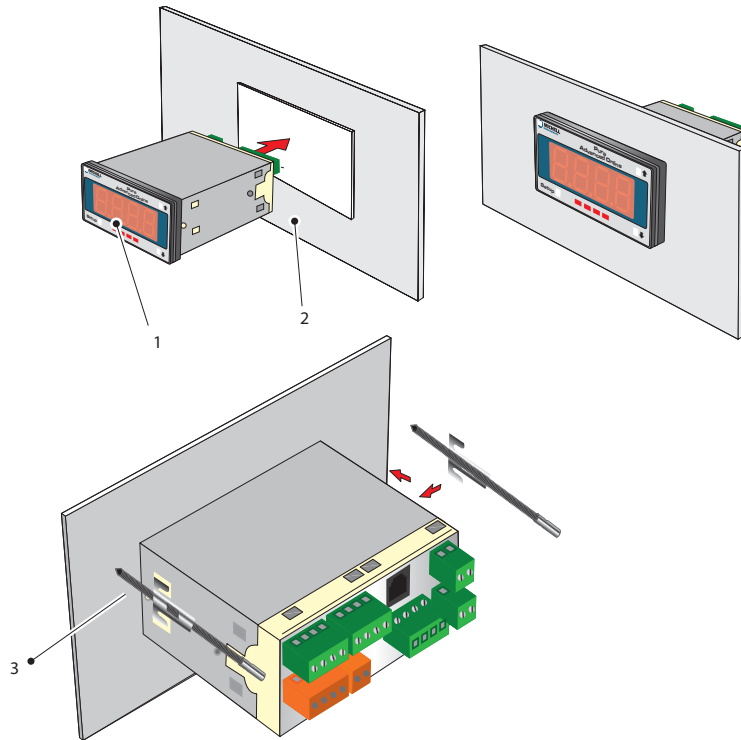

Figure 14 *Mounting the Monitor*

1. Pass the monitor (1) through the front of the panel (2).
2. Support the monitor and attach mounting fixing brackets onto the side of the monitor.
3. Tighten the fixing screw (3) finger tight, against the back of the panel.
4. Ensure that the monitor is sitting flush to the front of the panel (2) and tighten the fixing screws evenly against the back of the panel.

Caution: Do not overtighten the screws as this could cause the case to crack.

2.10 Electrical Connections

The power supply voltage is indicated on the connection detail label located on the monitor. As the monitor is provided for continuous operation it does not have an ON/OFF switch.

The power supply to the monitor may be one of the following, dependant on the type ordered.

2.10.1 High Voltage Power Supply Input

For high voltage powered display

- 85...265 V AC 50/60 Hz and 95...370 V DC



It is essential that the connection of electrical supplies to this instrument is undertaken by competent personnel.

Connect the power supply to the monitor (1) as shown in *Figure 15*.

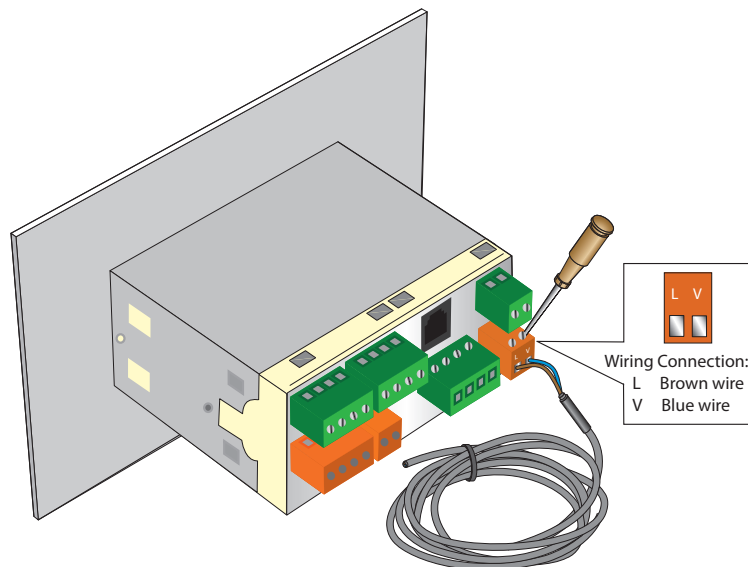

Figure 15 *High Voltage Power Supply Connections*

2.10.2 Low Voltage Power Supply Input (Optional)

For low voltage powered display

- 18...36 V AC and 9...60 V DC

Connect the power supply to the monitor (1) as shown in *Figure 16*.

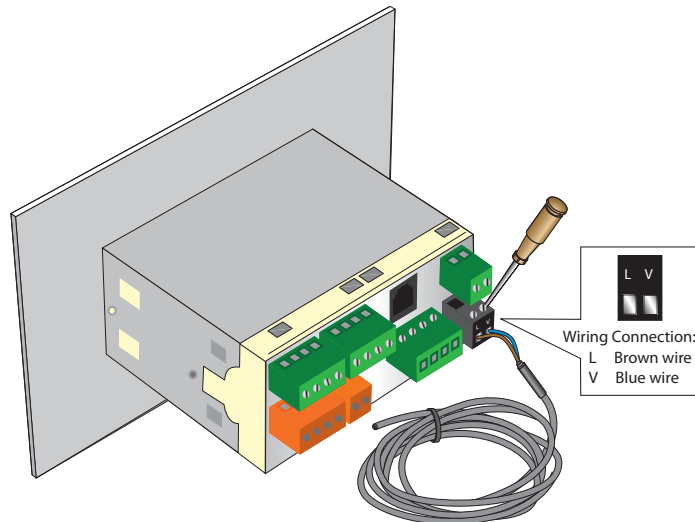

Figure 16 *Low Voltage Power Supply Connections*

2.11 Pressure Transducer Connection (Optional)

The monitor provides excitation voltage (24 V DC @ 20 mA) for an auxiliary 2-wire transmitter used in the dual channel configuration. Connect (+) of the pressure transmitter to pin 6 of the monitor and (-) of the pressure transmitter to pin 5 of the monitor. Refer to *Figure 17* for details.

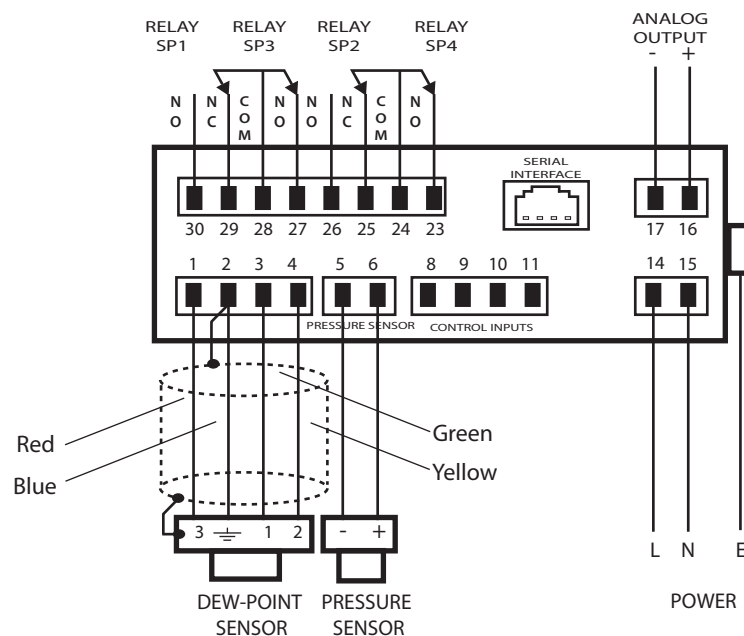

Figure 17 *Electrical Connection Detail*

2.12 Transmitter Connections

Connect the transmitter cable to the monitor as shown below.

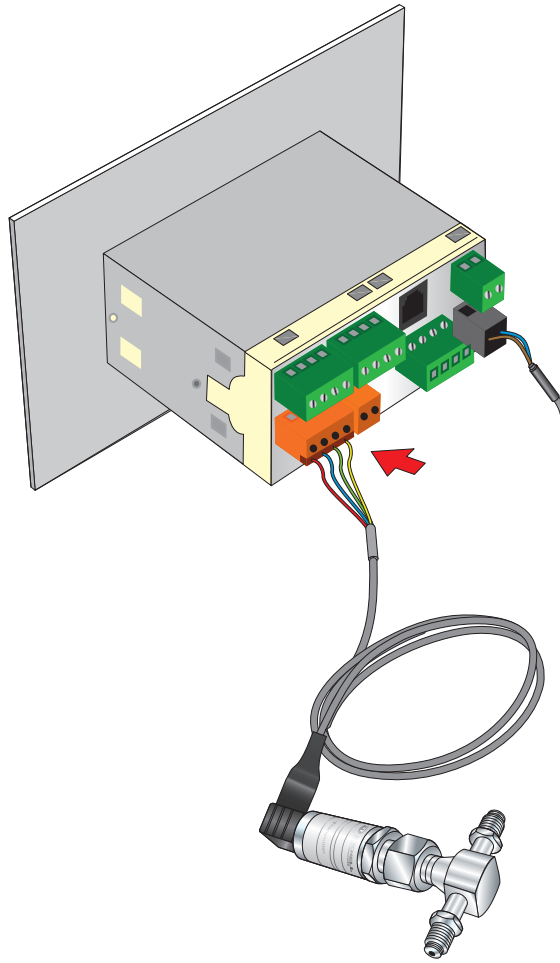

Figure 18 *Transmitter Connections*

3 OPERATION



When the instrument is first powered-up the display may show a zero value for about 1 second, followed by a flashing OPEN for approximately 5 seconds, before showing a dew-point value.

This is normal and does not indicate a problem with the instrument.

There are two levels of operation:

User (No access to programming codes)	Advanced (Access to programming codes)
Changing display brightness	Alarm configuration
View alarm setpoints	Analog output calibration and scaling
	Auxiliary (optional) input channel set-up
	Setting the engineering units
	Transmitter connection fault relay set-up
	Other related advanced functions

Table 2 Operation Access Levels

3.1 Set-Up Security Feature

To prevent unauthorized access, the monitor has two DIP-switches that can be accessed by removal of the faceplate (refer to *Figure 19*).

The **ON** position protects that mode, **OFF** makes alterations possible.

- The **SETPOINT LOCKOUT** switch (SW1) enables or disables Alarm Setpoint Programming mode.
- The **PROGRAM LOCKOUT** switch (SW2) enables or disables Code Programming mode.

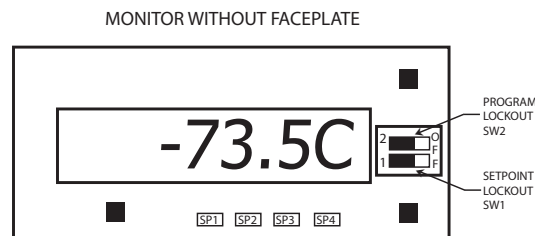

Figure 19 Location of the Lockout switches

3.1.1 Selecting the Engineering Units

1. Ensure security lockout switches are in the OFF position (Section 3.1)
2. While pressing **SETUP**, press **↑** once. Release both buttons and keep pressing **SETUP** until **CODE 7** is displayed.

The monitor can display and output a variety of different engineering units. The selection of engineering units is achieved by setting **CODE 4** and **CODE 7** as shown below.

To set the range and resolution for ppb_v and ppm_v , set digit 3 of **CODE 7** to:-

Required Display Unit	CODE 4	CODE 7	Range
Dew point in °C	207	000	
Dew point in °F	217	000	
ppm_v	-	100	1...9999 ppm_v
ppm_v	-	101	0.1...999.9 ppm_v
ppm_v	-	102	0.01...99.99 ppm_v
ppm_v	-	103	0.001...9.999 ppm_v
ppb_v		104	0.01...99.99 ppb_v

Table 3 Engineering Unit Selection

For example: setting **CODE 7** to 104, displays ppb_v with a resolution of 0.01 to a maximum of 99.99. Should the measured value exceed 100 ppb_v with this setting, **oVER** will be displayed.

3.1.2 Configuring the Alarms

Ensure security lockout switches are in the OFF position (Section 3.1) before proceeding.

Press **SETUP** and **↓** simultaneously to access the **SP_n** and **SPC_n** settings.

Alarm Setpoint

The setpoints of the relays are set by setting **SP_n** (where n = 1 to 4 and represent SP1 to 4), to the required level.

Digit 1 of **SPC_n** controls the type of alarm. For the relays to be energized above the setpoint **SPC_n = 0xx**

For the relays to be energized below the setpoint **SPC_n = 1xx**

Alarm Source

Digit 2 of SPC_n controls the source of the alarm.

0	Displayed value (DEFAULT) – the alarm setpoint is based on the current engineering unit
1	Dew Point only
2	Pressure
3	Open transmitter connection
4	Open / short circuit transmitter
5	Open / short circuit thermistor
6	All transmitter faults

For example; if you wish the relay to trip at a certain dew-point value whilst the indicator is displaying ppm_v, then **SPC_n = x1x**.

Alarm Secondary Function

Digit 3 of SPC_n controls the secondary function of the alarm.

0	No function (DEFAULT)
1	Relay latched
2	De-energize relay
3	No function
4	Relay OFF for open transmitter connection
5	Relay ON for open transmitter connection
6	Relay toggles at 1 Hz for transmitter fault
7	Setup for hysteresis, delay type and make \ break delay times

For example, if you wish the relay to trip above the setpoint using the displayed value, but to remain latched, then **SPC_n = 001**. It will then remain latched until the monitor is powered off or **SPC_n = 002**.

LED Alarm Annunciators

The function of the relay annunciators is set by digit 1 of **CODE 1** i.e. **nxx**. As shown below:

0	LED annunciators always OFF
1	LED annunciators ON when relays are de-energized
2	LED annunciators ON when relays are energized (DEFAULT)

3.1.3 Hysteresis, Make/Break Delay & Delay Type

Associated with each alarm is a Hysteresis Value, Make delay time, Break delay time and a Delay type. To gain access to these parameters, set **SPC_n = xx7**, and scroll to the features by pressing the **↑** or **↓** buttons.

- The hysteresis value is the value above and below the nominal setpoint at which the relay trips.
- The Make delay time is the time delay between the setpoint being reached and the relay energizing.
- The Break delay time is the time delay between the relay being energized and it de-energizing.

- The maximum make and break delay time is 9 hours, 6 minutes, 6 seconds, in increments of 1 second.

The setpoint can have four different Delay types:

- **NorM** (normal)
- **rEPt** (repeat)
- **1Shot**
- **PuLSE**

Delay Type	Behaviour
NorM	The relay will function normally with the inclusion of the time delays
rEPt	The make and break delays will repeat continually until the setpoint source returns to a level that deactivates the setpoint
1Shot	The relay will energize after the entered delay period and remain energized
PuLSE	The relay will energize, de-energize after the period entered and thereafter will remain de-energized

3.1.4 Analog Output Scaling

1. Ensure security lockout switches are in the OFF position (Section 3.1)
2. Press **SETUP**, followed by the **↑** button, then **SETUP** again.
3. Press the **↑** or **↓** buttons to scroll through to the **CAL** menu. The analog output can be scaled by setting **CAL** to 061 and setting the zero value to the required output at 4 mA (or 0 V) and the full scale value to the output required at 20 mA (or 10 V).
4. To exit the **CAL** menu press **SETUP**, set **CAL** to 000 and use the **↑** button to scroll through the menus.

See Appendix B, Setup Codes, for more information on output scaling options.

3.1.5 Display Brightness Adjustment

1. To adjust the display brightness press the **SETUP** and **↑** buttons simultaneously.
2. The display toggles between [**bri**] and [**5**], where 5 is the default setting.
3. Adjust the display brightness required (from 0 to 7) by pressing the **↑** or **↓** buttons.
4. Press **SETUP** seven times to exit the programming mode.

3.2 Pressure Compensation

Ensure security lockout switches are in the OFF position (Section 3.1)

The monitor has the ability to measure pressure in order to provide a pressure compensated value for ppm_v.

3.3 Using a Pressure Transducer

In order to enable the use of a pressure transducer set **CODE 4** to 307 (dual channel mode), and while pressing **SETUP**, press **▲** once. Release both buttons and keep pressing **SETUP** until **CODE 4** is displayed.

- To display dew point whilst measuring pressure, set **CODE 4** to 307 to show dew point in °C; or 317 for dew point in °F.
- To display pressure in psig set **CODE 6** to 000; or to display pressure in barg set **CODE 6** to 100.

3.3.1 Manual Pressure Input Calibration

The pressure input channel must be configured to the range of the pressure transducer. This is achieved by setting **CAL** to 012 and entering values for offset **OFF_2** and scale **SCA_2**.

SCA_2 = 0.0062 per 100 psig

OFF_2 = pressure range – ((20,000 x (pressure range\1000))\16)

For example, for a pressure transducer with a range of 0...1000 psig:

SCA_2 = 0.0062 x 10 = 0.0620

OFF_2 = 1000 – ((20,000 x (1000\1000))\16) = -250

If you are using a pressure transducer in barg, convert the value to psig using a multiplier of 14.5. For example, for a pressure transducer with a range of 0...100 barg:

SCA_2 = 0.0062 x 14.5 = 0.0899

OFF_2 = 1450 – ((20,000 x (1450\1000))\16) = -362

To exit the **CAL** menu, set **CAL** to 000 and press the **SETUP** button six times to return to the main screen.

3.3.2 Automatic Pressure Input Calibration

Alternatively, the pressure input can be calibrated using a 4...20 mA source.

1. Connect the current source between pin 2 (-ve) and pin 5 (+ve).
2. Set **CAL** to 022 and press **SETUP**. The monitor will then display **ZERo** and flash 0.
3. Set the mA source to 4.0 mA and press **SETUP** to set 0 at 4 mA.
4. Press **SETUP** and the monitor will display **SPAN** and flash the full scale pressure value.
5. Set the mA source to 20.0 mA and use the **↑** or **↓** buttons to set the required pressure range.
6. Press **SETUP** to set the required pressure for 20.0 mA.
7. Set **CAL** to 000 and press the **↑** button to leave the menu.

3.4 Using a Fixed Pressure Input in Single Channel Mode

In order to display pressure compensated values of ppm_v and ppb_v without the use of a pressure transducer, enter the pressure value manually.

1. Ensure security lockout switches are in the OFF position (Section 3.1).
2. Press **SETUP** and the **↑** button to scroll through the menus and select **CODE 7**.
3. Select the required pressure compensated value, i.e. **CODE 7** = 10X for ppm_v / ppb_v and **CAL** = 052 (see Table 3).
4. Exit the menus (see Section 3.1) and exit the **PROGRAM UNLOCK** mode.
5. Press **SETUP** for two seconds. The display will show the set pressure. To change the pressure, use the **↑** or **↓** buttons and then press **SETUP** to confirm.

4 MAINTENANCE

4.1 Maintenance and Calibration

Routine maintenance of the Pura Transmitter is confined to regular re-calibration. For most applications, annual re-calibration ensures that the stated accuracy of the Pura Transmitter is maintained.

Specialist calibration instrumentation is required to calibrate the transmitter and a true calibration can only be performed by exposure of the dew-point sensor to a reference gas of known dew point.

Calibration services are offered by Michell Instruments at their accredited calibration laboratories. All calibrations are traceable to national standards either via the National Physical Laboratory (UK) or the National Institute of Standards and Technology (USA).

The Pura transmitter can be returned to Michell Instruments either directly or via the authorized distributor, for calibration.

Alternatively, Michell Instruments can provide an exchange transmitter. Prior to re-calibration, an exchange transmitter can be ordered from Michell Instruments or an authorized distributor.

Once the replacement transmitter and calibration certificate have been received, the original transmitter can be disconnected and the replacement transmitter fitted in its place. The original transmitter should be packed in its original packing, if possible, and returned to Michell Instruments, either directly or via an authorized agent.

VCR Gasket

VCR gaskets should be replaced every time any VCR connection is re-made. Replacement VCR gaskets can be obtained from Michell Instruments.

O-ring Seal

If the supplied O-ring seal is damaged or lost a pack of 5 replacement O-ring seals can be obtained by contacting your Michell Instruments representative.

4.2 Fault Conditions

Display	Cause	Action
OPEN	Transmitter failure	Check power supply to transmitter. Check sensor cable for continuity/damage. Rectify/replace cable
	Instrument failure	Refer to Michell or local representative for repair
FAIL	Transmitter failure	Replace transmitter
0.0	Gas is wetter than -40 °C (-40 °F) dew point	Check gas source supply
	Transmitter contaminated	Replace/re-calibrate transmitter

5 MEASUREMENT GUIDE

5.1 Sampling Considerations

There are two basic methods of measuring a sample with the Pura Transmitter:

- In-situ measurements are made by placing the transmitter inside the environment to be measured.
- Extractive measurements are made by installing the sensor into a block within a sample handling system, and flowing the sample outside of the environment to be measured through this system.

Extractive measurements are recommended when the conditions in the environment to be measured are not conducive to making reliable measurements with the product.

Examples of such conditional limitations are:

- Excessive flow rate
- Presence of particulates matter
- Presence of entrained liquids
- Excessive sample temperature

The basic considerations for each measurement type are as follows:

In-Situ

- 1. Dew-Point Sensor Position** – will the sensor see an area of the environment that is representative of what you want to measure?

For example, if the sensor is to be mounted into a glove box, there are three different positions in which it could be installed – each giving a different measurement:

- Position A is on the purge inlet. In this position the sensor will confirm the dew point of the gas entering the glove box, but will not detect any leaks in the glove box itself, or any moisture released from the work piece.
- Position B is on the gas outlet. In this position the sensor will be exposed to the gas leaving the glove box, and will therefore be detecting any moisture which has entered into the system (e.g. ingress/leaks), or has been released by the work piece.
- Position C is in the glovebox itself, in this position the sensor will be only detecting any moisture in its immediate vicinity. Leaks not in close proximity to the measurement point may not be detected as this moisture could be drawn directly to the outlet.

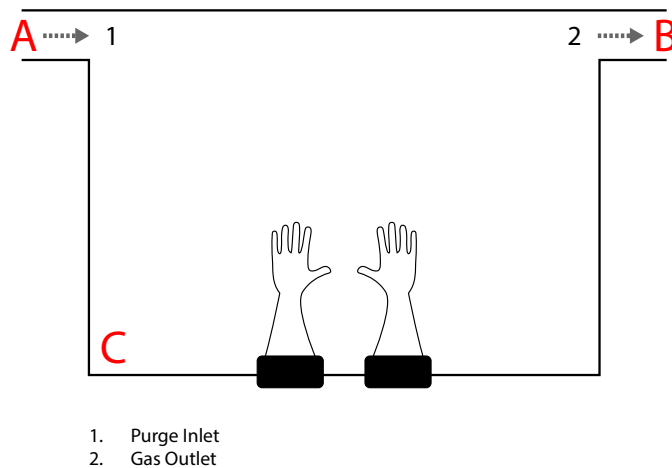

Figure 20 *Installation Location*

If the transmitter is to be mounted directly into a pipe or duct, then consider that the installation point should not be too close to the bottom of a bend where oil or other condensate may collect.

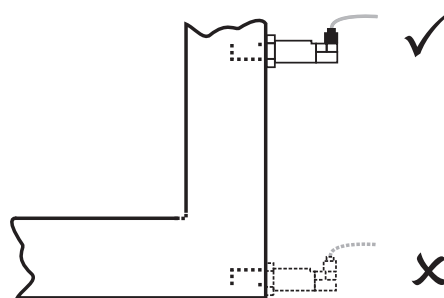

Figure 21 *Installation Location*

- 2. Gas speed** – if you are planning on installing the sensor in a duct, consider how fast the sample gas is moving through it.

If the gas speed is very low, or occasionally static, then the moisture content through the length (and width, if it is more than a few cm across) of the duct is unlikely to be uniform.

Extremely high gas speeds can cause damage to the sensor. Direct insertion is not recommended in gas speeds in excess of 10m/s (32.8ft/s).

- 3. Particulates** – Particulates travelling at speed can cause severe and irreversible damage to the sensor. At low velocity they can cling to the sensor, reducing its' surface area, and therefore response speed.

The sensor is provided with a basic level of particulate protection in the form of a sintered guard; either HMWPE (10µm pore size) or Stainless Steel (80µm pore size). If the sample stream contains smaller particulates than this, or generally large amounts of dust; extractive measurement is recommended to accommodate proper in-line filtration.

- 4. Sample Temperature** – Although the Pura can be operated at sample temperatures up to 60 °C, it is advisable to keep the sample temperature as close to ambient, and as stable as possible to keep adsorption & desorption characteristics as consistent as possible (see Section 5.2, Sampling Hints, for more information).

Extractive

If the sensor is to be mounted into a sample conditioning system, then the above points are still of relevance, but it is important to consider the extraction point itself – make sure that the chosen extraction point is representative of the process, i.e. that the sample of interest is flowing past the extraction point, and it is not being pulled from a dead volume.

5.2 Sampling Hints

Measurement of moisture content is a complex subject, but does not need to be difficult. This section aims to explain the common mistakes made in measurement situations, the causes of the problem, and how to avoid them. Mistakes and bad practices can cause the measurement to vary from the expectation; therefore a good sampling technique is crucial for accurate and reliable results.

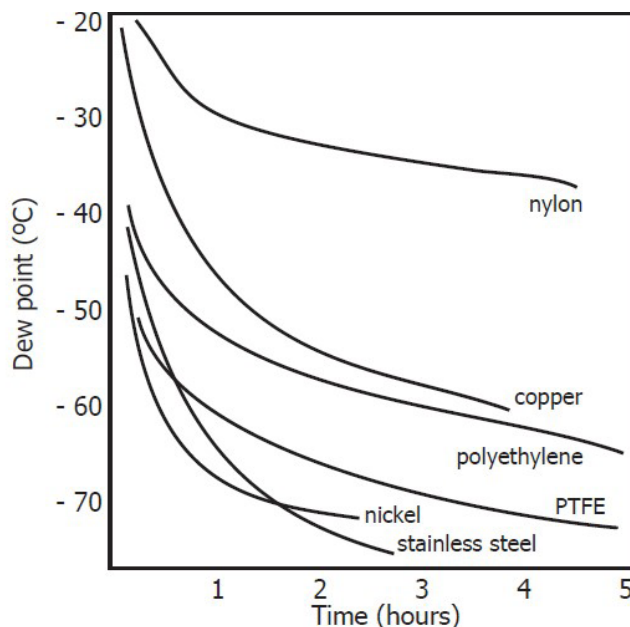

Figure 22 *Material Permeability Comparison*

All materials are permeable to water vapor, as the water molecule is extremely small compared to the structure of solids, even when compared to the crystalline structure of metals. The graph above shows the dew point inside tubing of different materials when purged with very dry gas, where the exterior of the tubing is in the ambient environment.

Many materials contain moisture as part of their structure, particularly organic materials (natural or synthetic), salts (or anything which contains them) and anything which has small pores. It is important to ensure that the materials used are suitable for the application.

If the partial water vapor pressure exerted on the outside of a compressed air line is higher than on the inside, the atmospheric water vapor will naturally push through the porous medium causing water to migrate into the pressurised air line. This effect is called transpiration.

Adsorption and Desorption

Adsorption is the adhesion of atoms, ions, or molecules from a gas, liquid, or dissolved solid to the surface of a material, creating a film. The rate of adsorption is increased at higher pressures and lower temperatures.

Desorption is the release of a substance from or through the surface of a material. In constant environmental conditions, an adsorbed substance will remain on a surface almost indefinitely. However, as the temperature rises, so does the likelihood of desorption occurring.

In practical terms, as the temperature of the environment fluctuates, water molecules are adsorbed and desorbed from the internal surfaces of the sample tubing, causing small fluctuations in the measured dew point.

Sample Tubing Length

The sample point should always be as close to the critical measurement point as possible, in order to obtain a truly representative measurement. The length of the sample line to the sensor or instrument should be as short as possible. Interconnection points and valves trap moisture, so using the simplest sampling arrangement possible will reduce the time it takes for the sample system to dry out when purged with dry gas.

Over a long tubing run, water will inevitably migrate into any line, and the effects of adsorption and desorption will become more apparent. It is clear from the graph shown above that the best materials to resist transpiration are stainless steel and PTFE.

Trapped Moisture

Dead volumes (areas which are not in a direct flow path) in sample lines, hold onto water molecules which are slowly released into the passing gas; this results in increased purge and response times, and wetter than expected readings. Hygroscopic materials in filters, valves (e.g. rubber from pressure regulators) or any other parts of the system can also trap moisture.

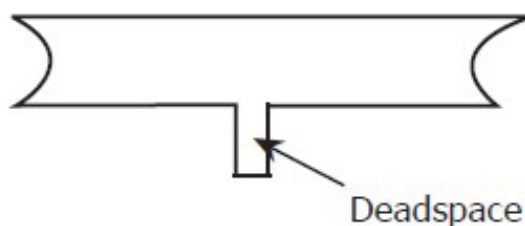

Figure 23 *Dead volume*

Sample Conditioning

Sample conditioning is often necessary to avoid exposure of sensitive measuring components to liquids and other contaminants which may cause damage or affect the accuracy over time, depending on the measurement technology.

Particulate filters are used for removing dirt, rust, scale and any other solids that may be in a sample stream. For protection against liquids, a coalescing filter should be used.

The membrane filter is a more expensive but highly effective alternative to a coalescing filter. It provides protection from liquid droplets, and can even stop flow to the analyser completely when a large slug of liquid is encountered.

Condensation and Leaks

Maintaining the temperature of the sample system tubing above the dew point of the sample is vital to prevent condensation. Any condensation invalidates the sampling process as it changes the water vapor content of the gas being measured. Condensed liquid can alter the humidity elsewhere by dripping or running to other locations where it may re-evaporate.

The integrity of all connections is also an important consideration, especially when sampling low dew points at an elevated pressure. If a small leak occurs in a high pressure line, gas will leak out but vortices at the leak point and a negative vapor pressure differential will also allow water vapor to contaminate the flow.

Flow Rates

Theoretically flow rate has no direct effect on the measured moisture content, but in practice it can have unanticipated effects on response speed and accuracy. The optimal flow rate varies depending on the measurement technology, and can always be found in the instrument or sensor manual.

An inadequate flow rate can:

- Accentuate adsorption and desorption effects on the gas passing through the sampling system.
- Allow pockets of wet gas to remain undisturbed in a complex sampling system, which will then gradually be released into the sample flow.
- Increase the chance of contamination from back diffusion: ambient air that is wetter than the sample can flow from the exhaust back into the system. A longer exhaust (sometimes called a pigtail) can also help alleviate this problem.
- Slow the response of the sensor to changes in moisture content.

Appendix A

Technical Specifications

Appendix A Technical Specifications

Performance	
Measurement Range	-120 °C...-40 °C (-184 °F...-40 °F) dew point 0...9999 ppm _v 0...99.99 ppb _v
Accuracy	Dew point ±0.5 °C, ±1.0 °F ppm _v ±1% of reading secondary channel ±0.5% FS
Response Time	T95 to -60°C (-76°F) dew point in <3 minutes
Repeatability	0.5°C dew point
Sensor Calibration	Traceable 9-point calibration certificate
Electrical Specifications	
Outputs	4...20 mA as standard or 0...20 mA optional (max load 500 Ω) or 0...10 V optional (min load 5 K Ω), scaleable by user
Online Output	Dew point
Maximum Analog Output Scaled Range	Dew point: -120 °C...-40 °C (-184 °F...-40 °F)
Online Supply Voltage	AC: 85...264V AC
Online Current Consumption	60 mA maximum
Electrical Safety	BS/EN61010-1
Operating Specifications	
Operating Temperature	Sensor: -20 °C...+50 °C (-4 °F...+122 °F); Monitor: 0 °C...+50 °C (+32 °F...+122 °F), 0...90 %rh
Compensated Temperature Range	Sensor: -20 °C...+50 °C (-4 °F...+122 °F); Monitor: not applicable
Storage Temperature	Sensor: -40 °C...+75 °C (-40 °F...+167 °F); Monitor: -10 °C ...+60 °C (+14 °F...+140 °F)
Operating Pressure	10 ⁻⁹ torr to 30 MPa (300 barg/4350 psig)
Sensor Flow Rate	1...5 l/min
Mechanical Specifications	
Ingress Protection	Sensor MiniDIN: IP66 in accordance with standard BS EN 60529:1992+A2:2013; NEMA 4 protection in accordance with standard NEMA 250–2014 Sensor M12: IP65 Monitor: IP65 (NEMA 4X) front panel only
Sensor Housing Material	316 stainless steel
Dimensions	Sensor MiniDIN: L=133 mm x ø45 mm (with connector cable) Monitor: 1/8 DIN Case, 96 x 48 x 85 mm (w x h x d)
Sensor Process Connection	Pura SEN- 1/2" VCR female process connection Pura OEM & PRM 2 x 1/4" VCR male process connection
Sensor Weight	Pura PRM & OEM – 450 g (15.8 oz)
Sensor Electrical Connections	MiniDIN 43650 form C, M12 5 pin (A coded)
Online Sensor Cable	0.8, 2, 5, 10 metre connector/cable available
Sensor Diagnostic Conditions (factory programmed)	Sensor fault: 23 mA Under-range dew point: 4 mA Over-range dew point: 20 mA

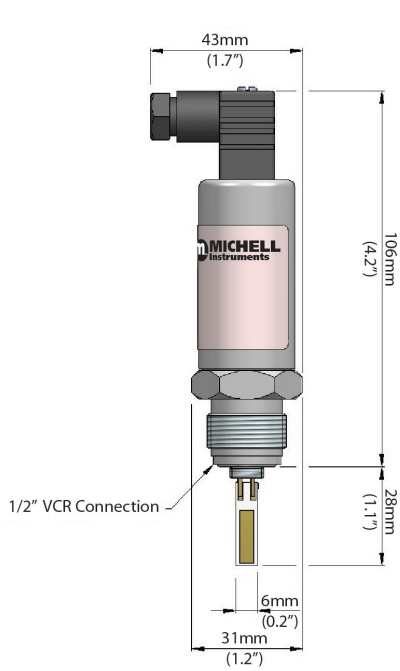

Figure 24 Pura SEN

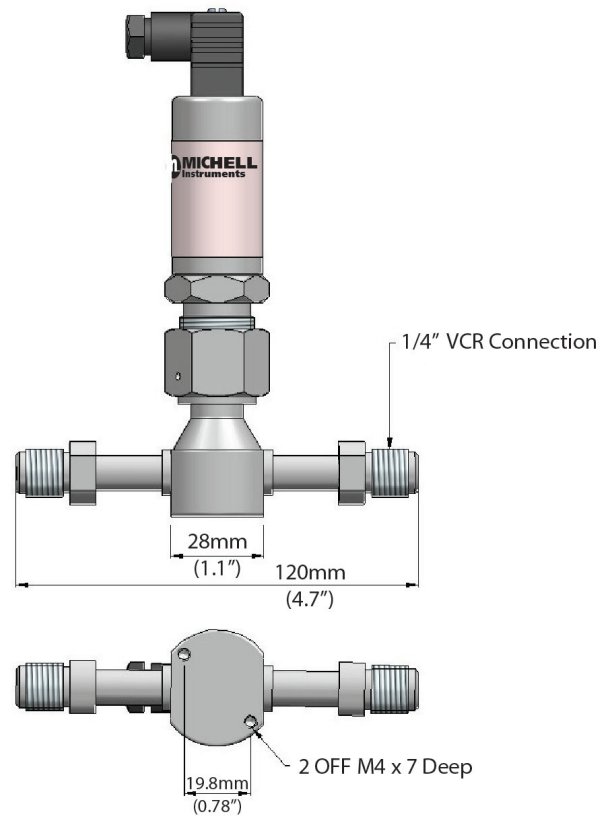

Figure 25 Pura PRM & OEM

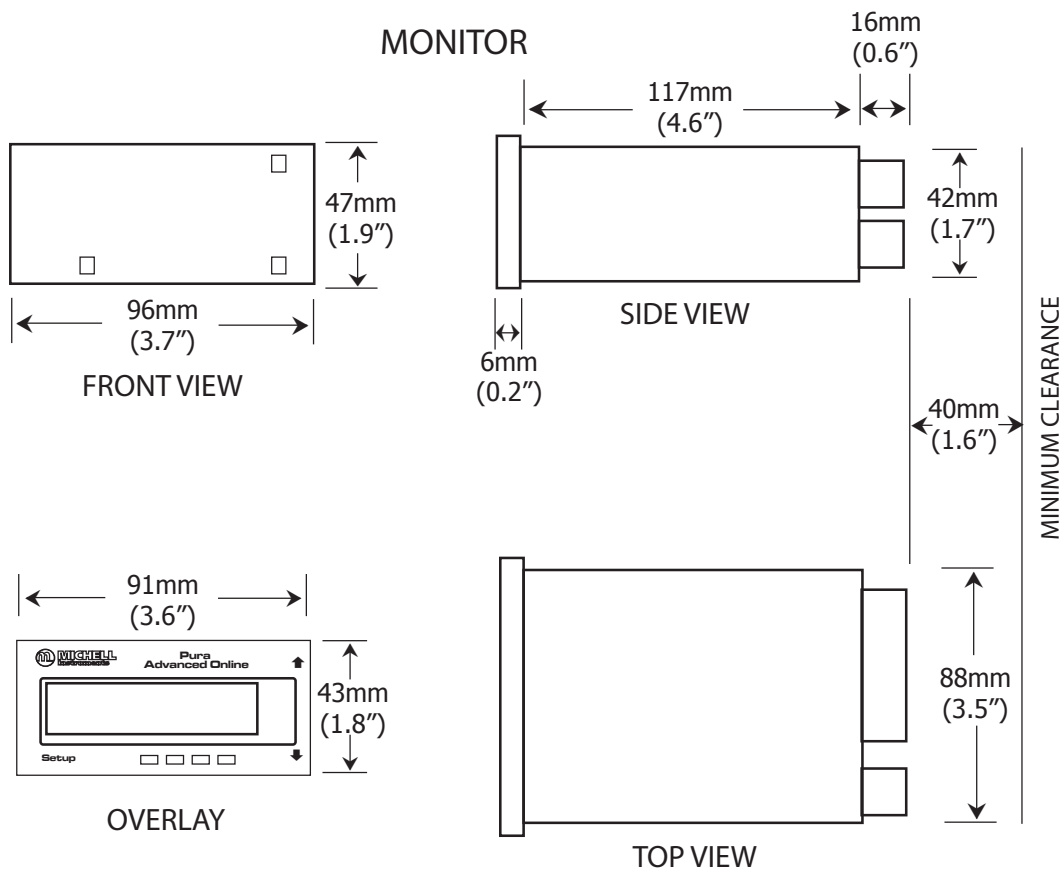

Figure 26 Monitor Dimensions

Appendix B

Setup Codes

Appendix B Setup Codes

CAL Calibration modes for input and output DEFAULT VALUE = 052

Digit	1st digit (left most) Calibration Mode	2nd digit Calibration Function	3rd digit Object for Calibration
0	Calibration functions as per 2nd and 3rd digit	No function	No function
1	Set baud rate, parity and serial address	Manual calibration (channel as per 3rd digit)	Processed result (dew point, ppm _v and ppb _v)
2	N/A	N/A	Pressure input
3	N/A	N/A	N/A
4	N/A	N/A	N/A
5	N/A	Manual adjust	N/A
6	N/A	Analog output scaling (analog channel as per 3rd digit)	N/A

CODE 1 Tendency Indication, Additional LED's, Display data source, Flashing, Decimal points, Rounding DEFAULT VALUE = 200

Digit	1st digit (left most) Additional LED's	2nd digit Display Data Source	3rd digit 0 only (No Function)
0	LED annunciators are always off	Processed data – result (dew point, ppm _v , ppb _v)	N/A
1	LED annunciators are on when relays are de-energized	Processed data – channel 1 (dew point only)	N/A
2	LED annunciators are on when relays are energized	Processed data – pressure	N/A

CODE 3 Serial mode and Analog output source DEFAULT VALUE = 000

Digit	1st digit (left most) Serial Mode	2nd digit Analog Output 1 Source	3rd digit 0 only (No Function)
0	ASCII mode	Analog output 1 from processed result data (dew point, ppm _v , ppb _v)	N/A
1	N/A	Analog output 1 from processed data (dew point only)	N/A
2	N/A	Analog output 1 from processed data (pressure)	N/A

CODE 4 Channel 1 Measurement task, Sampling rate
DEFAULT VALUE = 207

Digit	1st digit (left most) Analog Sample Rate	2nd digit Analog Output 1 Source	3rd digit 0 only (No Function)
0	N/A	Dew point in degrees C	N/A
1	N/A	Dew point in degrees F	N/A
2	Single channel (50 Hz)	N/A	N/A
3	Dual channel (50 Hz)	N/A	N/A

CODE 6 Channel 2 Measurement task
DEFAULT VALUE = 000

Digit	1st digit (left most) Measurement Task	2nd digit 0 only (No Function)	3rd digit 0 only (No Function)
0	Pressure in psig	N/A	N/A
1	Pressure in barg	N/A	N/A

CODE 7 Result processing
DEFAULT VALUE = 000

Digit	1st digit (left most) Measurement Task	2nd digit Calibration Function	3rd digit Range for Result
0	Dew point	N/A	1 – 9999ppm _v
1	ppm _v /ppb _v	N/A	1 – 999.9ppm _v
2	N/A	N/A	0.01 – 99.99ppm _v
3	N/A	N/A	0.001 – 9.999ppm _v
4	N/A	N/A	0.01 – 99.99ppb _v

Setpoint control 1 – 6 Relay latching, relay setup, source
DEFAULT VALUE = 000 (Prog/Down menu after setpoints)

Digit	1st digit (left most) Relay Sense	2nd digit Setpoint Source	3rd digit Setpoint Function SP1 – SP4
0	Relay energized above setpoint value	Processed result data (dew point, ppm _v , ppb _v)	No function
1	Relay energized below setpoint value	Dew point only	Relay latched
2	N/A	Pressure	De-energized relay
3	N/A	Open transmitter connection	N/A
4	N/A	Open / short circuit transmitter	Relay off for open transmitter connection
5	N/A	Open / short circuit thermistor	Relay on for open transmitter connection
6	N/A	All transmitter faults	Relay toggles at 1 Hz for transmitter connection fault
7	N/A	N/A	Set-up hysteresis, make/break delay and delay type

Appendix C

Quality, Recycling & Warranty Information

Appendix C Quality, Recycling & Warranty Information

Michell Instruments is dedicated to complying to all relevant legislation and directives. Full information can be found on our website at:

www.michell.com/compliance

This page contains information on the following directives:

- Anti-Facilitation of Tax Evasion Policy
- ATEX Directive
- Calibration Facilities
- Conflict Minerals
- FCC Statement
- Manufacturing Quality
- Modern Slavery Statement
- Pressure Equipment Directive
- REACH
- RoHS3
- WEEE2
- Recycling Policy
- Warranty and Returns

This information is also available in PDF format.

Appendix D

Return Document & Decontamination Declaration

Appendix D Return Document & Decontamination Declaration

Decontamination Certificate

IMPORTANT NOTE: Please complete this form prior to this instrument, or any components, leaving your site and being returned to us, or, where applicable, prior to any work being carried out by a Michell engineer at your site.

Instrument			Serial Number	
Warranty Repair?	YES	NO	Original PO #	
Company Name			Contact Name	
Address				
Telephone #		E-mail address		
Reason for Return /Description of Fault:				
Has this equipment been exposed (internally or externally) to any of the following? Please circle (YES/NO) as applicable and provide details below				
Biohazards	YES		NO	
Biological agents	YES		NO	
Hazardous chemicals	YES		NO	
Radioactive substances	YES		NO	
Other hazards	YES		NO	
Please provide details of any hazardous materials used with this equipment as indicated above (use continuation sheet if necessary)				
Your method of cleaning/decontamination				
Has the equipment been cleaned and decontaminated?	YES		NOT NECESSARY	
Michell Instruments will not accept instruments that have been exposed to toxins, radio-activity or bio-hazardous materials. For most applications involving solvents, acidic, basic, flammable or toxic gases a simple purge with dry gas (dew point <-30°C) over 24 hours should be sufficient to decontaminate the unit prior to return. Work will not be carried out on any unit that does not have a completed decontamination declaration.				
Decontamination Declaration				
I declare that the information above is true and complete to the best of my knowledge, and it is safe for Michell personnel to service or repair the returned instrument.				
Name (Print)			Position	
Signature			Date	





Instrument Expert
Original factory
packaging
www.keruiyiqi.cn

www.ProcessSensing.com



<http://www.michell.com>