

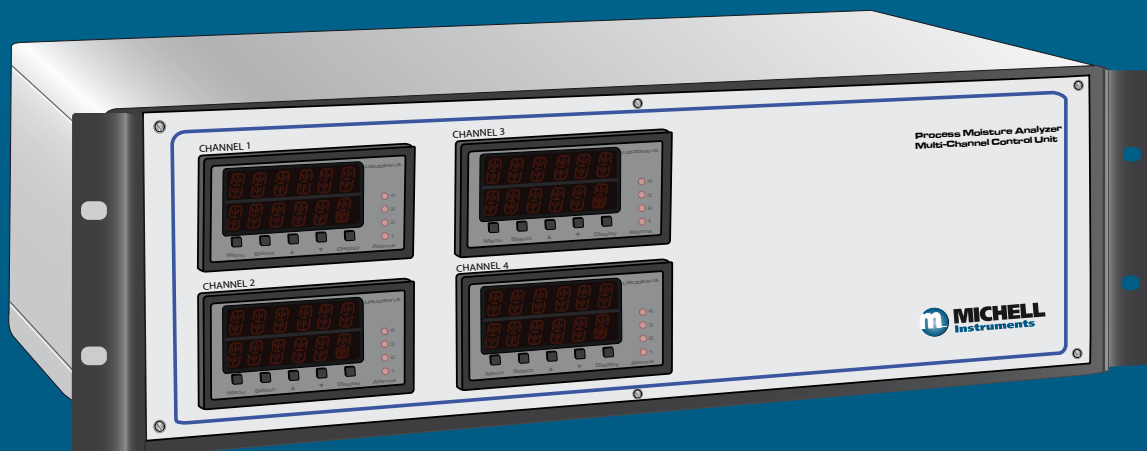

Liquidew I.S. Process Moisture Analyzer User Manual



Please fill out the form(s) below for each instrument that has been purchased.

Use this information when contacting Michell Instruments for service purposes.

Product Name	
Order Code	
Serial Number	
Invoice Date	
Installation Location	
Tag Number	

Product Name	
Order Code	
Serial Number	
Invoice Date	
Installation Location	
Tag Number	

Product Name	
Order Code	
Serial Number	
Invoice Date	
Installation Location	
Tag Number	



Liquidew I.S. Process Moisture Analyzer

For Michell Instruments' contact information please go to
www.michell.com

© 2021 Michell Instruments

This document is the property of Michell Instruments Ltd and may not be copied or otherwise reproduced, communicated in any way to third parties, nor stored in any Data Processing System without the express written authorization of Michell Instruments Ltd.

Contents

Safety	vii
Electrical Safety.....	vii
Pressure Safety	vii
Toxic Materials	vii
Repair and Maintenance.....	vii
Calibration	vii
Safety Conformity.....	vii
Abbreviations.....	viii
Warnings	viii
1 INTRODUCTION	1
1.1 Performance Features	2
1.2 Applications.....	2
1.3 Theory of Operation.....	3
1.4 System Components	4
1.4.1 User Interface	5
1.4.2 Power Supply and Input/Output Signal	7
1.5 Sampling System	8
2 INSTALLATION.....	9
2.1 Unpacking the Analyzer.....	9
2.2 Operating Requirements.....	10
2.2.1 Environmental Requirements	10
2.2.2 Power Requirement.....	10
2.3 Mounting	10
2.3.1 Control Unit Installation.....	10
2.3.2 Mounting the Liquidew I.S. Sensor Assembly into the Sampling System	12
2.3.3 Sampling System Installation	14
2.4 Wiring.....	15
2.4.1 Overall Wiring Arrangement.....	15
2.4.2 Control Unit Wiring	16
2.4.2.1 Power Supply Input Connection.....	18
2.4.2.2 Sensor Signal Input Connection.....	20
2.4.2.3 Analog Output Connection	21
2.4.2.4 Alarm Output Connection.....	22
2.4.2.5 RS485 Port Connection	23
2.4.3 Sensor Assembly Wiring	24
2.4.3.1 Dew-point Transmitter Wiring.....	24
2.4.3.2 Temperature Transmitter Wiring	27
3 OPERATION.....	29
3.1 Preparation	29
3.2 Start-Up	29
3.2.1 Function Keys Activation.....	29
3.2.2 Powering-up the Analyzer.....	30
3.2.3 Sample Flow Start-Up.....	31
3.3 Menu Structure.....	32
3.4 Main Reading Page	34
3.5 Liquid Set-Up.....	34
3.5.1 Liquid Selection	34
3.5.2 User-Defined Liquid.....	35
3.5.3 Liquid Mixing	36
3.6 Analog Output 1 (Moisture Content or Dew Point - User-Selectable)	38
3.6.1 Output Source Selection	38
3.6.2 Output Range ZERO Value Settings	39
3.6.3 Output Range SPAN Value Settings	39
3.7 Analog Output 2 (Sample Temperature - Only).....	39

3.8	System Fault Alarm Set-Up	40
3.8.1	Minimum Dew-Point Value for the Fault Alarm.....	40
3.8.2	Maximum Dew-Point Value for the Fault Alarm	40
3.8.3	Minimum Temperature Value for the Fault Alarm	41
3.8.4	Maximum Temperature Value for the Fault Alarm	41
3.9	Alarm Setting	42
3.9.1	Alarm Set-Point Adjustment.....	42
3.9.2	Alarm Type Selection.....	43
3.9.3	Alarm Source Selection.....	44
3.10	Display Brightness Adjustment.....	45

Figures

Figure 1	Liquidew I.S. Control Unit.....	1
Figure 2	Structure of the Michell Ceramic Moisture Sensor	3
Figure 3	Major Components of the Liquidew I.S.	4
Figure 4	User Interface	5
Figure 5	Dimensions of the Control Unit	10
Figure 6	Rack Mounting Method.....	11
Figure 7	Liquidew I.S. Sensor Assembly.....	12
Figure 8	Overall Wiring Arrangement.....	15
Figure 9	Control Unit Electrical Connections	17
Figure 10	POWER INPUT Socket.....	18
Figure 11	POWER INPUT Connector Block	19
Figure 12	SENSOR INPUTS Connector Block	20
Figure 13	OUTPUT Connector Block	21
Figure 14	ALARM Connector Block	22
Figure 15	Crimped Wires.....	25
Figure 16	Cut to 5mm.....	25
Figure 17	Dew-Point Transmitter Housing	25
Figure 18	Dew-Point Transmitter Pin Assignment Drawing.....	26
Figure 19	Temperature Transmitter Housing	27
Figure 20	Temperature Transmitter Pin Assignment Drawing.....	28
Figure 21	Units of Measurement Readings in Sequence	30
Figure 22	Menu Maps.....	33
Figure 23	Dimensional Drawings.....	49

Tables

Table 1	Liquid List	34
---------	-------------------	----

Appendices

Appendix A	Technical Specifications	47
	A.1 Dimensional Drawings.....	49
Appendix B	Serial Communications	51
Appendix C	Modbus RTU Comms	56
Appendix D	Hazardous Area Certification	59
	D.1 Product Standards	59
	D.2 Product Certification.....	59
	D.3 Global Certificates/Approvals	59
	D.4 Terminal Parameters	60
	D.5 Special Conditions.....	60
	D.6 Maintenance and Installation	60
Appendix E	System Drawings	62
	E.1 Baseefa Approved System Drawing	62
	E.2 QPS Approved System Drawing.....	63
Appendix F	Quality, Recycling & Warranty Information	65
Appendix G	Return Document & Decontamination Declaration	67

Safety

The manufacturer has designed this equipment to be safe when operated using the procedures detailed in this manual. The user must not use this equipment for any other purpose than that stated. Do not apply values greater than the maximum value stated.

This manual contains operating and safety instructions, which must be followed to ensure the safe operation and to maintain the equipment in a safe condition. The safety instructions are either warnings or cautions issued to protect the user and the equipment from injury or damage. Use competent personnel using good engineering practice for all procedures in this manual.

Electrical Safety

The instrument is designed to be completely safe when used with options and accessories supplied by the manufacturer for use with the instrument. The input power supply voltage is 85...265 V AC or 10...72 V DC. Refer to labels on instrument or calibration certificate.

Pressure Safety

DO NOT permit pressures greater than the safe working pressure, as defined in the published specifications, to be applied to the instrument.

Toxic Materials

The use of hazardous materials in the construction of this instrument has been minimized. During normal operation it is not possible for the user to come into contact with any hazardous substance which might be employed in the construction of the instrument. Care should, however, be exercised during maintenance and the disposal of certain parts.

Long exposure to, or breathing of, the calibration gases may be dangerous.

Repair and Maintenance

The instrument must be maintained either by the manufacturer or an accredited service agent. Refer to www.michell.com for details of Michell Instruments' worldwide offices contact information.

Calibration

The recommended calibration interval for the analyzer is 12 months (6 months or less for aggressive fluids) depending on the application in which the instrument is used. Please consult Michell Instruments for the specific calibration interval (refer to www.michell.com for details of Michell Instruments' worldwide offices contact information.).

Safety Conformity

This product meets the essential protection requirements of the relevant UK, EU and US standards and directives. Further details of applied standards may be found in the Technical Specifications in Appendix A.

Abbreviations

The following abbreviations are used in this manual:

A	Ampere
AC	alternating current
barg	pressure unit (=100 kP or 0.987 atm) gauge
°C	degrees Celsius
°F	degrees Fahrenheit
DC	direct current
dp	dew point
GPM	gallons per minute
"	inch(es)
lbf-ft	pound force per foot
l/min	liters per minute
Nm	newton meter
mA	milli Ampere
psig	pressure in pound(s) per square inch (gauge)
ppm _w	parts per million by weight
T	temperature
V	Volts

Warnings

The following general warnings listed below are applicable to this instrument. They are repeated in the text in the appropriate locations.



Where this hazard warning symbol appears in the following sections it is used to indicate areas where potentially hazardous operations need to be carried out.



Where this symbol appears in the following sections it is used to indicate areas of potential risk of electric shock.

1 INTRODUCTION

The Liquidew I.S. Process Moisture Analyzer is a continuous, on-line instrument for the measurement of absolute moisture content in a liquid. It is designed to fulfil a wide range of applications and provide for the monitoring and/or control of moisture in liquids. The instrument consists of two component parts: the control unit and the sensors (moisture and temperature transmitters). They are individually calibrated to a single standard allowing for total interchangeability between combinations of sensors and control units.

The range of the instrument is 0...500 parts per million by weight (ppm_w). There are 8 pre-set liquid options available for the C_s data used in moisture calculation, together with 2 user-defined solutes and an ability to mix any 2 liquids from the list. Four alarm relay contacts are provided which are user-configurable in set-point and operating mode. The current output is factory set at 4...20 mA.

The Liquidew I.S. Control Unit must be placed in a non-hazardous area suitable for electronic analytical equipment. The moisture and temperature transmitters can be positioned close to the process sample take-off point in a Zone 0, 1 or Zone 2 (Class I, Division 1, Groups A, B, C & D) hazardous area. The control unit and transmitters are connected via a standard 2-wire instrumentation cable protected by safety isolation interface units.



Figure 1 *Liquidew I.S. Control Unit*

1.1 Performance Features

- State-of-the-art ceramic moisture sensor with chemically inert materials coupled with physical resilience provides long-term reliability in the most arduous applications. Robust construction is exceedingly durable in liquid. Not affected by pressure shocks.
- High integrity moisture in liquid measurement from 0.01ppm_w to saturation level at +20°C (68°F).
- Sample Analysis over temperature range 0...+50°C maximum (32...122°F)
- Two 4...20 mA outputs with configurable units / ranges. RS485 Modbus RTU communication. Four built-in user-adjustable alarm contacts.
- Assured measurement accuracy with each sensor calibrated across the entire measurement range and certified traceable to NPL (UK) and NIST (USA).
- Certified intrinsically safe.
- Replaceable sensor element with Michell Calibration Exchange Service for professional, scheduled and low cost recalibration to minimize downtime and cost.
- Up to four independent measurement channels with any combination of moisture in gas and moisture in liquid measurement at low per-channel cost.
- Customized sampling systems to meet even the most demanding applications.

1.2 Applications

- Petrochemical process liquids monitoring
- Catalyst protection
- Prevents acid formation during reactor process
- Controls moisture in solvents for polymer production
- Monitor liquid fuels to avoid supply line blockage
- Lubricant oil monitoring for preventative maintenance
- Monitor transformer oil to prevent insulation breakdown

1.3 Theory of Operation

Reliable and robust sensor design is fundamental to achieving accurate measurement of moisture in liquids over a long period of time. Proprietary thick- and thin-film techniques are applied in the Michell Ceramic Moisture Sensor. Base metal layers, on semi-conductor grade ceramic substrate, sense dissolved moisture within the sample liquid flow. The inert materials of the sensor have a high resistance to aggressive media while the inherent strength of the sensor and the thermal bonded connections to the active device ensures reliable operation even in dense fluid samples.

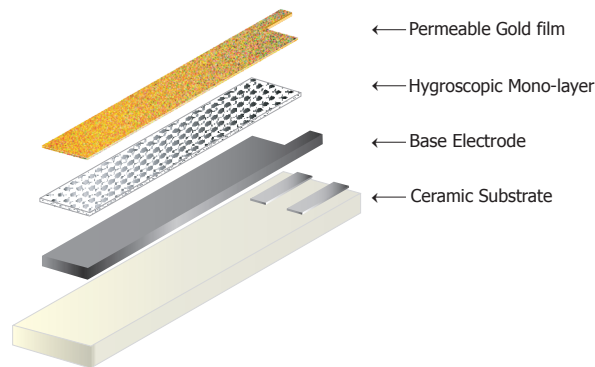

Figure 2 Structure of the Michell Ceramic Moisture Sensor

The ceramic moisture sensor exhibits a direct response to partial pressure of moisture vapor. Calibration is certified traceable to NPL (UK) and NIST (USA) through the use of dew-point transfer standards.

With the Liquidew I.S. the amount of dissolved moisture dispersed throughout the immiscible process liquid is measured on-line in real time (in units of ppm_w moisture content) using Henry's Law.

According to Henry's Law:

$$C = \frac{C_s}{P_{sat}} \times P_w$$

Where:

- C = Moisture content
- C_s = Saturation moisture content at the analysis temperature
- P_w = Water vapor pressure from dew-point sensor measurement
- P_{sat} = Saturation water vapor pressure at the analysis temperature

$$C_s / P_{sat} = K \text{ (Henry constant)}$$

The impedance sensor measures P_w. To calculate C, the C_s must be known.

The advanced firmware of the Liquidew I.S. provides moisture measurements in ppm_w through the application of Henry's Law using pre-programmed saturation concentration (C_s) values for the most common pure hydrocarbon liquid applications. A proportional mixing setting can be used for mixtures of two solutes, i.e. propane and butane in LPG.

Two user-programmable entry tables enable C_s values to be entered for other solutes or for complex fluid compositions where the user may wish to enter C_s values from:

- their own sources
- laboratory analysis of process samples
- estimated values from proportional calculation based on the C_s values for each of the major components in the solute mix

1.4 System Components

The Liquidew I.S. Process Moisture Analyzer consists of:

- the sensor assembly
- the control unit

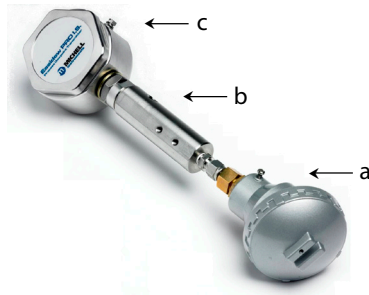

Sensor Assembly

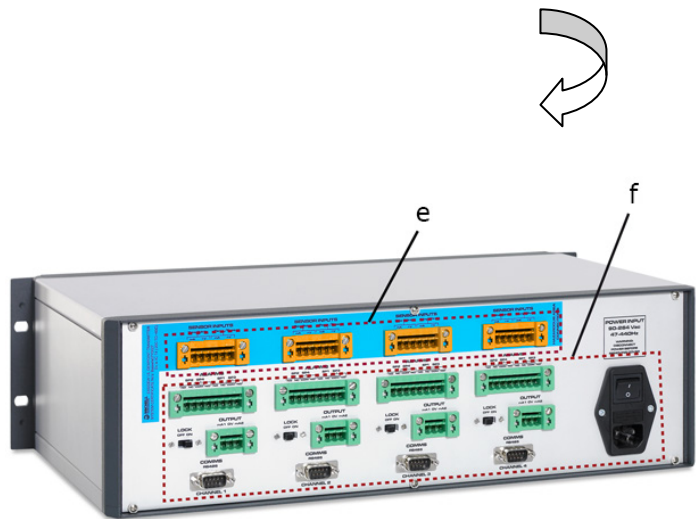
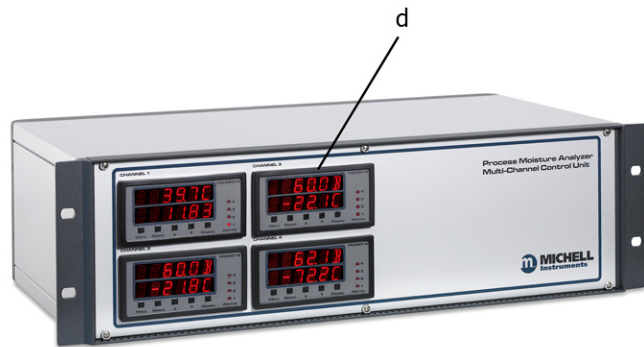

Control Unit

(Up to four channels can have any combination of Liquidew I.S. and Promet I.S.*)

a	Temperature transmitter
b	Sensor block
c	Dew-point transmitter
d	User interface
e	Electrical connections - to hazardous area
f	Electrical connections - non-hazardous

Figure 3 Major Components of the Liquidew I.S.

* Promet I.S. is a sister product of the Liquidew I.S. and is used for moisture in gas measurement

1.4.1 User Interface

The Liquidew I.S. user interface is located on the control unit. There is a two-line, six digit (15 segment) LED display and four alarm indicators. Five push-button function keys facilitate data display, parameter setting and system adjustment.



Figure 4 *User Interface*

The operation of the function keys are shown below and more information can be found in Section 3.

- **Menu key:**

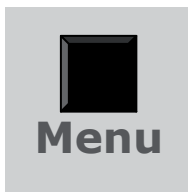

The **Menu** key is used to enter and exit the set-up menu.

At any level within the set-up menu, press and hold the **Menu** key to return to the default screen.

- **Select key:**

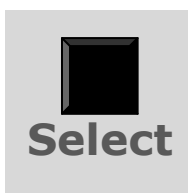

The **Select** key is used to enter the sub-menu and to confirm the selection.

- **▲ key:**

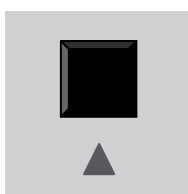

The **▲** key is used to scroll up through pages in the top and sub-level menus and to increase values in sub-level menus.

- ▼ key:

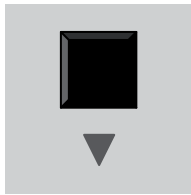

The ▼ key is used to scroll down through pages in the top and sub-level menus and to decrease values in sub-level menus.

- Display key

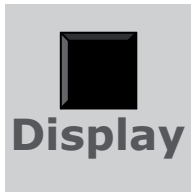

The **Display** key is used to change the display unit (see Section 3.2.2).

The four LED alarm indicators will light up when the specific alarm relay is activated. Settings for the alarm relays are explained in Section 3.99.

1.4.2 Power Supply and Input/Output Signal

The terminal blocks for the power supply, signal input, signal output and alarm output are located on the back panel of the control unit (as shown in *Figure 9*).

- **Power Supply**

The Liquidew I.S. requires either 85...265 V AC or 10...72 V DC power input, depending on the model ordered.

- **Signal Input**

There are two 4...20 mA signal input channels from the dew-point and temperature sensors to the control unit. Both input channels are isolated by built-in galvanic type I.S. barriers.

- **Signal Output**

There are two 4...20 mA linear signal output channels. The output channel 1 is used for the dew point, moisture or temperature signal, with configurable ranges. Output channel 2 has a fixed temperature signal and cannot be configured.

There is one RS485 Modbus RTU digital communication port. Please refer to Appendix B.

- **Alarm Output**

There are four alarm relays. Alarms 1 and 2 are Form C contacts rated 10A / 240 V AC or 8A / 24 V DC, non-inductive load. Alarms 3 and 4 are Form A contacts rated 5A / 240 V AC or 4A / 24 V DC, non-inductive load. The control actions and set points of these four alarms are user-programmable. A fault alarm with adjustable set points is also included.

1.5 Sampling System

The Liquidew I.S. requires a clean sample of the process liquid that meets the temperature, pressure and flow requirements of the transmitter. The design of the sampling system will depend on the specific application.

The requirements for the sample liquid going into the sensor block are as follows:

- Temperature: 0...+40 °C (+32...+104 °F) (maximum +60 °C (+140 °F))

NOTE: Sample temperature must be above the moisture saturation temperature of the sample fluid

- Maximum pressure: 45 MPa (450 barg / 6526 psig)
- Flow rate: 0.1...0.3 l/min (0.026...0.079 GPM)

NOTE: Contact Michell Instruments if you wish to order a specific sampling system.

Please refer to the Liquidew I.S. Premium Sampling System Instructions if a Michell sampling system has been ordered with the Liquidew I.S.

2 INSTALLATION



It is essential that the installation of the electrical and liquid supplies to this analyzer be undertaken by suitably qualified personnel.

2.1 Unpacking the Analyzer

Unpack carefully as follows:

- a. Remove the accessories (if ordered).
- b. If no accessories have been ordered the delivery should contain following items:
 - Liquidew I.S. control unit
 - Liquidew I.S. sensor assembly (if a sampling system has been ordered the sensor assembly should already be mounted in the sampling system)
 - User manual
 - Certificates of calibration and conformity
 - Power lead (only for 85...265 V AC version)
- c. Remove the Liquidew I.S. sensor assembly from the box.
- d. Lift out the control unit together with its end packing pieces.
- e. Remove the end packing pieces and set the control unit down at the site of installation. Save all the packing materials for the purpose of returning the instrument to the manufacturer for service.

If ordered, the Liquidew I.S. Premium Sampling System will be shipped in a separate box.

2.2 Operating Requirements

2.2.1 Environmental Requirements

The Liquidew I.S. sensor assembly is intrinsically safe and designed to be installed on-site, indoors or outdoors, directly at the point of measurement within a Hazardous Area. The sensor assembly is ATEX, IECEx and QPS certified. To operate correctly, the sensor assembly must be installed within a suitable sampling system (Michell Instruments can supply standard and custom designed sampling systems).

The Liquidew I.S. control unit is NOT designed for use in a Hazardous Area and should only be installed in a safe area. The control unit is intended for indoor installation only and operates within environmental limits of 0...+50 °C (+32...+122 °F) and <90%RH. The control unit contains built-in isolation barriers permitting connection, direct from the Hazardous Area, of the Liquidew I.S. sensor assembly.

2.2.2 Power Requirement

The Liquidew I.S. control unit can be ordered for either of the following electrical supplies:

- 85...265 V AC, 47/63 Hz @ 4W max 10W

OR

- 10...72 V DC @ 4W max 10W

The Liquidew I.S. sensor assembly is powered through the 2-wire signal cable directly from the control unit.

Please refer to the Liquidew I.S. Premium Sampling System Instructions for the power requirement of the sampling system.

2.3 Mounting

2.3.1 Control Unit Installation

The Liquidew I.S. control unit is contained in a 19" sub-rack case (size 3U). It should be installed in a 19" rack using the mounting holes provided. It must be placed in a position free from any appreciable vibration and shaded from direct sunlight.

NOTE: The materials and construction of the control unit allow for operation in an indoor, clean, non-hazardous only, control room environment.

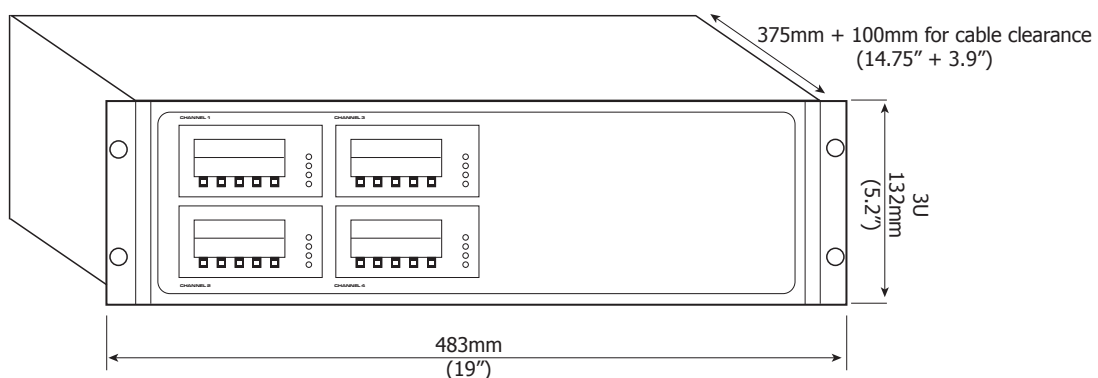

Figure 5 Dimensions of the Control Unit

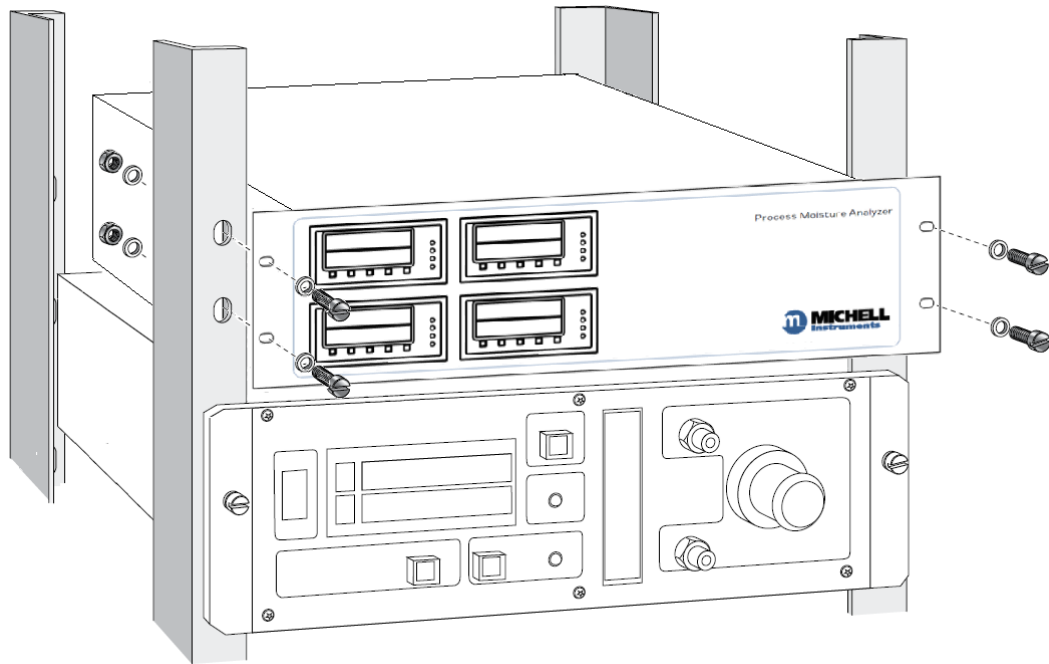

Figure 6 *Rack Mounting Method*

Figure 6 illustrates the general method for fitting a rack mount instrument into a standard 19" rack. To fit the unit proceed as follows:

- a. Remove all terminal blocks for the electrical connections.
- b. If necessary, remove any covers from the rack cabinet to gain access to the rear and side.
- c. Connect up the sensor input, analog and alarm output terminal blocks to the internal rack wiring, ensuring that there is sufficient free cable to permit withdrawal of the instrument from the rack.
- d. Slide the instrument into the rack and support its weight while the four fixing screws are inserted.
- e. Ensure that the front panel of the instrument is flush and square with the front of the rack and tighten the fixing screws.
- f. Insert the terminal blocks into their respective sockets on the rear of the instrument.
- g. Connect the power supply cable and switch the **ON/OFF** switch to **ON**.
- h. Re-fit any covers to the rack as necessary.

NOTE: Allow a minimum clearance depth of 100mm (4") behind the instrument housing for cables and vents.

2.3.2 Mounting the Liquidew I.S. Sensor Assembly into the Sampling System



HIGH PRESSURE! High pressure liquids are potentially hazardous. Energy stored in these liquids can be released suddenly and with extreme force. High pressure systems should be assembled and operated only by people who have been trained in proper safety practices.

NOTE: If the analyzer has been ordered with a sampling system, the Liquidew I.S. sensor assembly will have been installed and tested in the factory. In that case disregard the following section and go to Section 2.3.3.

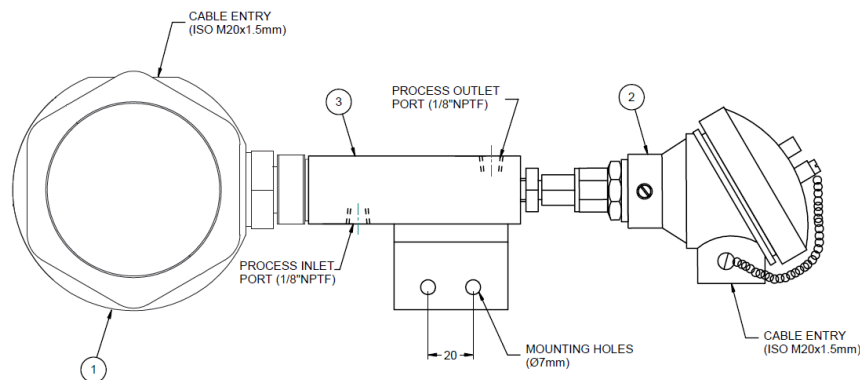

Figure 7 *Liquidew I.S. Sensor Assembly*

The Liquidew I.S. sensor assembly consists of:

- 1 Dew-point transmitter - Easidew PRO I.S.
- 2 Temperature transmitter
- 3 Sensor block

To assemble, proceed as follows:

- a. Remove the protective cap on the dew-point transmitter (Easidew PRO I.S.) before installation and retain for future use. Take care to prevent any contamination of the sensor before installation (**do not touch or handle the sintered guard - located on the tip of the Easidew PRO I.S.**).
- b. The dew-point transmitter has a 5/8" UNF parallel mounting thread which should be installed directly into the sampling block with the bonding seal provided. **The bonded seal provided should be placed over the transmitter mounting thread before it is screwed into the sampling block.**
- c. Finger-tighten the dew-point transmitter by gripping the spanner/wrench flats on the body - NOT the transmitter body cover. Completely tighten using a spanner/wrench until the bonded seal is fully compressed to a minimum torque of 30.5 Nm (22.5 lbf-ft).

- d. The temperature transmitter has a 6mm diameter probe. It is suitable for installing into the 1/8" NPT female port at the other end of the sensor block, by using the Swagelok® 6mm to 1/8" NPT, ordering code SS-6M0-1-2, 'bored-through' male connector. Follow the standard Swagelok® installation instructions to make the connection.

To install the complete Liquidew I.S. sensor assembly into the sampling system, follow these steps:

- a. Select a location to mount the sensor assembly which has sufficient clearance for connecting and disconnecting the inlet/outlet tubing and cable. The surface should be strong enough to hold the analyzer.
- b. Mount the Liquidew I.S. sensor assembly into the sampling system via its two mounting holes.

NOTE: The orientation of the sensor assembly should be vertical with the moisture sensor uppermost to minimize spillage of sample liquid when removing the moisture sensor for calibration maintenance.

- c. Sample liquid connections are made via the process inlet and process outlet ports as shown in *Figure 7*. Both the process inlet and outlet ports are 1/8" NPT female ports. Michell recommends using Swagelok® 6mm to 1/8" NPT (ordering code SS-6M0-1-2) or 1/4" to 1/8" NPT (ordering code SS-400-1-2) male connectors to connect these two ports to the 6mm or 1/4" sampling system tubing. Follow standard Swagelok® installation instructions to make the connections.

Although the operation of the Easidew PRO I.S. dew-point transmitter is not sample flow-rate dependant, it is important to ensure that the flow velocity through the sample line to the sampling block is high enough to avoid long time lags in response to changes in moisture at the sample source. Michell recommends that a flow-rate of 0.1...0.3 l/min (0.026...0.079 GPM) (or equivalent at pressure) be set and that the dew-point transmitter is mounted as close as practicably possible to the point of measurement.

2.3.3 Sampling System Installation



HIGH PRESSURE! High pressure liquids are potentially hazardous. Energy stored in these liquids can be released suddenly and with extreme force. High pressure systems should be assembled and operated only by people who have been trained in proper safety practices.

To install the sampling system follow the steps below:

- a. Select a location close to the measurement point. The ambient temperature should be within the range of -20...+60 °C (-4...+140 °F) (preferably 0...+40 °C (+32...+104 °F) for optimum performance). Consult Michell Instruments for special heating or cooling options if the temperature is outside of this range.
- b. Fasten the sampling system to a vertical surface or instrument stand using the four M8 size mounting holes at each corner.
- c. Connect the liquid inlet and outlet tubing to the fittings of the inlet/outlet ports on the sampling system. If the sampling system has been ordered from Michell Instruments, the fitting is a 6mm or 1/4" Swagelok® bulkhead union. Follow standard Swagelok® installation instructions when fitting these unions.

NOTE: The sampling line between the process point and the sampling system should be as short as possible to minimize the lag time.

2.4 Wiring



DANGER
Electric
Shock Risk

These tasks are to be undertaken only by suitably qualified personnel. All the connections to the rear panel are electrical connections. Exercise due caution, particularly when connecting to external alarm circuits which could be at high potential.

2.4.1 Overall Wiring Arrangement

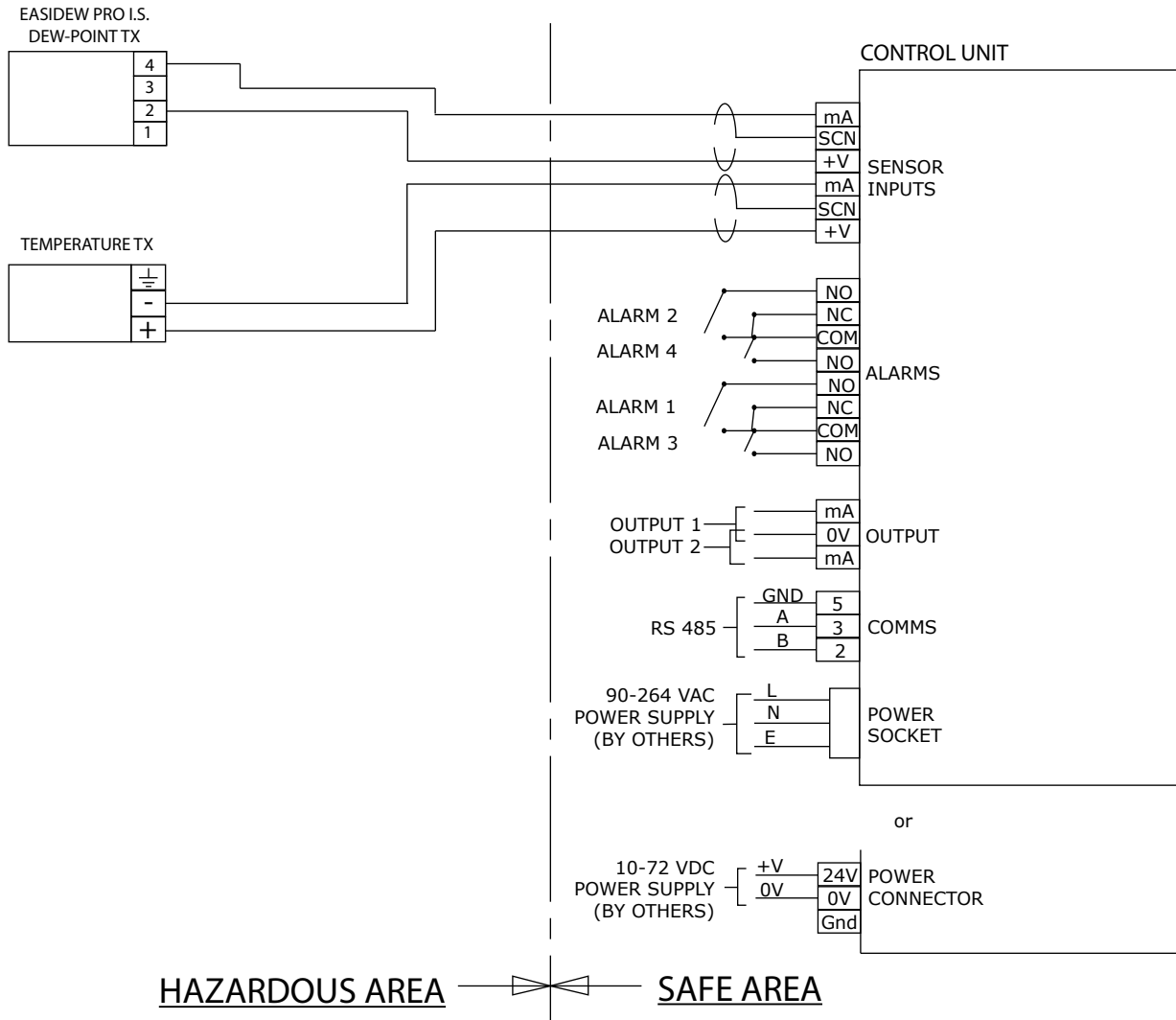

Figure 8 Overall Wiring Arrangement

2.4.2 Control Unit Wiring

The electrical connections are located at the rear panel of the control unit. There are spaces for four individual channels.



HAZARDOUS AREA INFORMATION:

The only connections on the control unit which can take cables from hazardous area are the connectors labelled SENSOR INPUTS.

ALL OTHER CONNECTORS MUST NOT BE CONNECTED TO CABLES FROM HAZARDOUS AREA

NOTE: Make sure channels are connected correctly.

Connections for each channel are identical.

The following text will only refer to one channel.

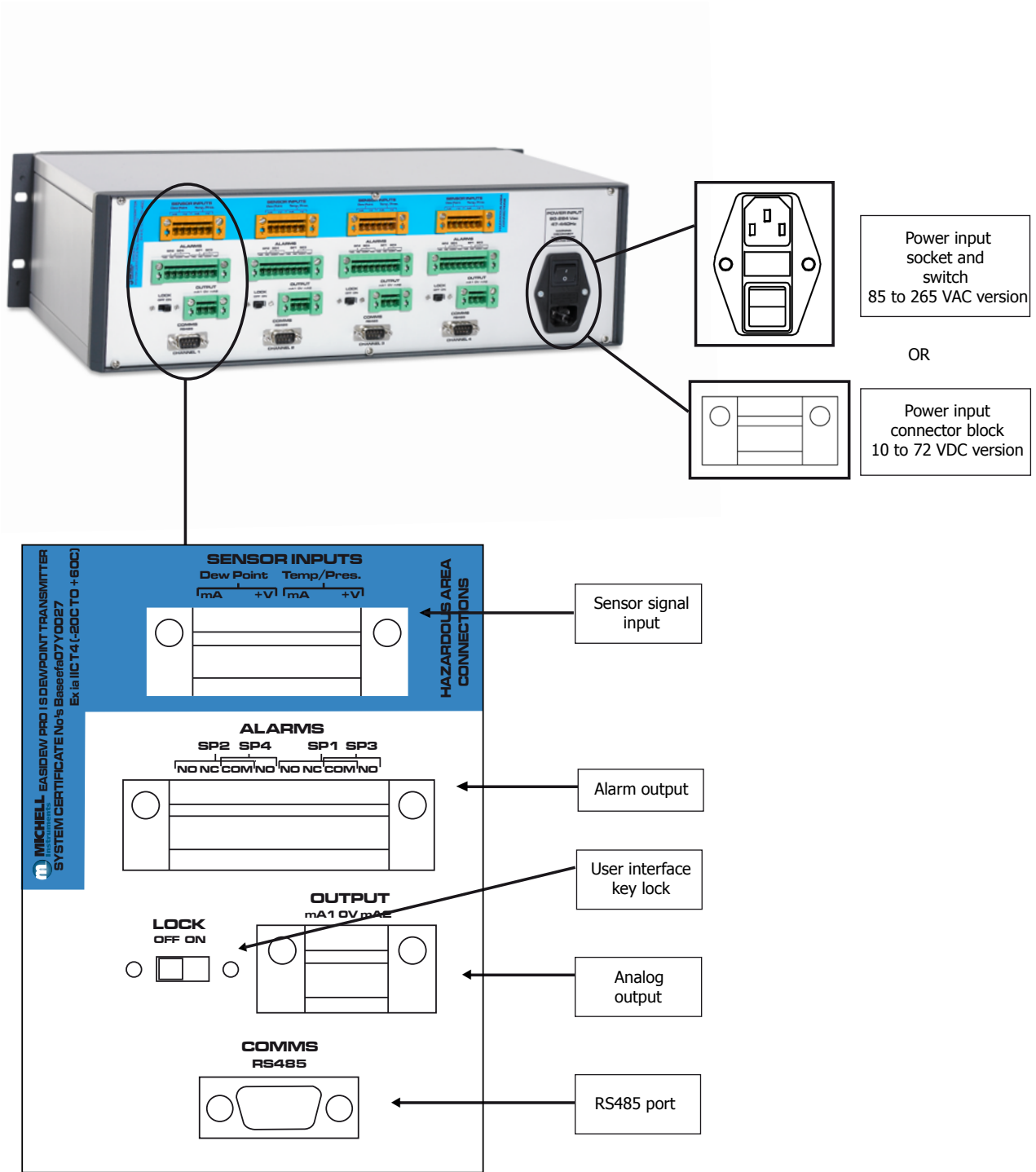

Figure 9 Control Unit Electrical Connections

2.4.2.1 Power Supply Input Connection

85...265 V AC

The AC power supply connection is a push fit socket labelled **POWER INPUT** as shown below.

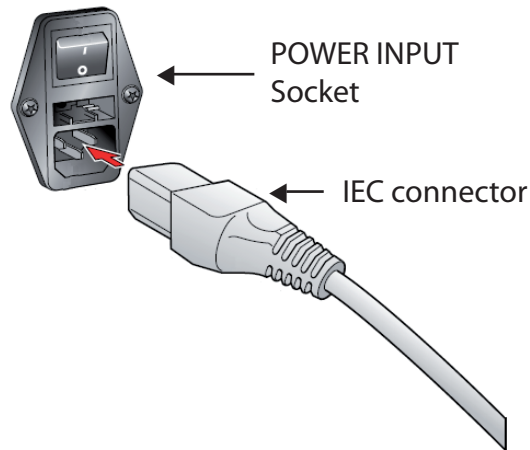

Figure 10 *POWER INPUT Socket*

The method of connection is as follows:

- a. Turn off the AC power. Ensure that both ends of the power cable are potential free, i.e. not connected to an AC power supply.
- b. Check that the **ON/OFF** switch is switched to **OFF**.
- c. Push the IEC connector firmly into the **POWER INPUT** socket.
- d. Connect the free end of the power cable to a suitable AC power supply source (voltage range 85...265 V AC, 47/63 Hz) and switch on the AC supply. The instrument may then be switched on, as required, by pressing the **ON** switch.

10...72 V DC

If a DC power supply version is ordered it will come with a 3-way push fit connector block labelled **POWER INPUT** as shown below:

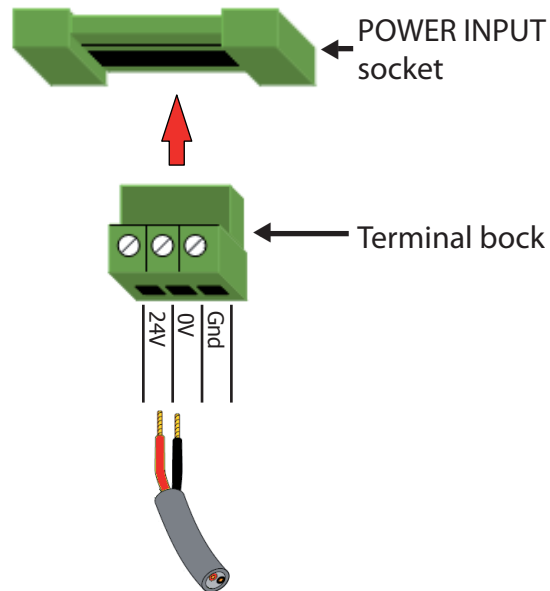

Figure 11 *POWER INPUT Connector Block*

The method of connection is as follows:

- a. Turn off the power. Ensure that both ends of the power cable are potential free i.e., not connected to a power supply.
- b. Remove the terminal block from the **POWER INPUT** socket.
- c. Strip back the wires of the power cable, exposing approximately 6mm (0.2") - the use of crimps/wire ferrules is recommended.
- d. Insert the +24 V DC lead into the **24V** terminal way on the terminal block and tighten the screw.
- e. Insert the 0V lead into the **0V** terminal way on the terminal block and tighten the screw.
- f. Check that the wiring has been completed correctly.
- g. Push the terminal block firmly back into the **POWER INPUT** socket.

NOTE: There is no power switch for the DC power supply version; the analyzer will be turned on automatically as soon as power is supplied. Connect the free end of the power cable to a suitable DC power supply source (voltage range 10...72 V DC). The instrument may then be switched on, as required, by the power switch at the source.

2.4.2.2 Sensor Signal Input Connection



HAZARDOUS AREA INFORMATION

Cables from transmitters mounted in hazardous areas can be connected directly to the SENSOR INPUTS connector block. There are built-in Galvanic I.S. barriers for all connections made to this connector block.

Refer to ATEX/QPS/IECEX certificates for the dew-point and temperature transmitters' connection cable requirements which stipulate maximum permissible mutual capacitance and inductance to resistance ratio.

All wiring procedures should be in accordance with local electrical codes.

Two input ports are provided for signals from the dew-point transmitter and the temperature transmitter respectively. They are connected via a single 6-way push fit connector block labelled **SENSOR INPUTS** as shown below.

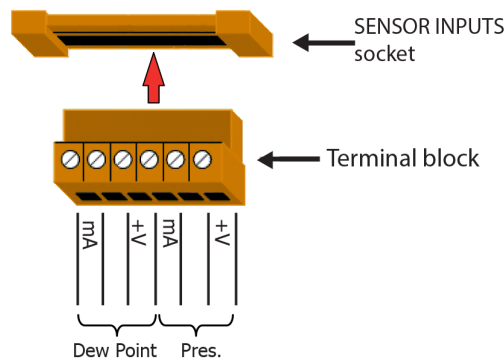

Figure 12 *SENSOR INPUTS Connector Block*

The method of connection is as follows:

- a. Remove the terminal block from the **SENSOR INPUTS** socket.
- b. Strip back the wires of the dew-point transmitter signal cable, exposing approximately 6mm (0.2")-the use of crimps/wire ferrules is recommended.
- c. Insert the +4...20 mA lead into the **Dew Point** → +V terminal way on the terminal block and tighten the screw.
- d. Insert the -4...20 mA lead into **Dew Point** → mA terminal way on the terminal block and tighten the screw.
- e. Strip back the wires of the temperature transmitter signal cable, exposing approximately 6mm (0.2") - the use of crimps/wire ferrules is recommended.
- f. Insert the +4...20 mA lead into the **Temp./Press.** → +V terminal way on the terminal block and tighten the screw.
- g. Insert the -4...20 mA lead into the **Temp./Press.** → mA terminal way on the terminal block and tighten the screw.
- h. Check that the wiring has been completed correctly.
- i. Push the terminal block firmly back into the **SENSOR INPUTS** socket.

2.4.2.3 Analog Output Connection

Two analog output ports are provided for moisture content signal and temperature signal respectively. They are connected via a single 3-way push fit connector block labelled **OUTPUT** as shown below.

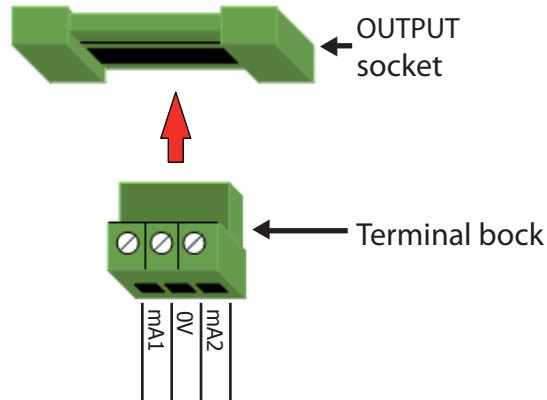

Figure 13 *OUTPUT Connector Block*

The method of connection is as follows:

- a. Remove the terminal block from the **OUTPUT** socket.
- b. Strip back the wires of the moisture content signal cable, exposing approximately 6mm (0.2") - the use of crimps/wire ferrules is recommended.
- c. Insert the +4...20 mA lead into the **mA1** terminal way on the terminal block and tighten the screw.
- d. Insert the -4...20 mA lead into the **0V** terminal way on the terminal block and tighten the screw.
- e. Strip back the wires of the temperature signal cable, exposing approximately 6mm (0.2") - the use of crimps/wire ferrules is recommended.
- f. Insert the +4...20 mA lead into the **mA2** terminal way on the terminal block and tighten the screw.
- g. Insert the -4...20 mA lead into the **0V** terminal way on the terminal block and tighten the screw.
- h. Check that the wiring has been completed correctly.
- i. Push the terminal block firmly back into the **OUTPUT** socket.

2.4.2.4 Alarm Output Connection

Four alarm output ports are provided and are connected to the instrument via a single 8-way push fit connector block labelled **ALARMS** as shown below.

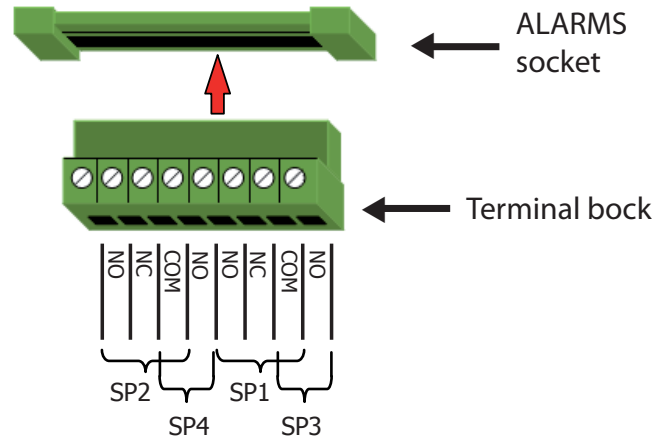
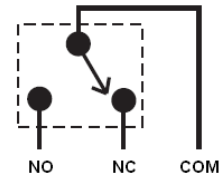

Figure 14 ALARM Connector Block

Alarm 1 (connection labelled as SP1) and Alarm 2 (connection labelled as SP2) are Form C (single pole, double throw) relays.

The method of connection is as follows:

- a. Remove the terminal block from the **ALARMS** socket.
- b. Strip back the wires of the Alarm 1 cable, exposing approximately 6mm (0.2") - the use of crimps/wire ferrules is recommended.
- c. Insert the **N/O** connection lead into the **SP1 → NO** terminal way on the terminal block and tighten the screw.
- d. Insert the **N/C** connection lead into the **SP1 → NC** terminal way on the terminal block and tighten the screw.
- e. Insert the common lead into the **SP1 → COM** terminal way on the terminal block and tighten the screw.
- f. Repeat operations b. to e. for connecting the Alarm 2 cable to the SP2 terminals.



Alarm 3 (connection labelled as SP3) and Alarm 4 (connection labelled as SP4) are Form A (single pole, single throw, normally open) relays.

The method of connection is as follows:

- a. Strip back the wires of the Alarm 3 cable, exposing approximately 6mm (0.2") - the use of crimps/wire ferrules is recommended.
- b. Insert the **N/O** connection lead into the **SP3 → NO** terminal way on the terminal block and tighten the screw.
- c. Insert the common lead into the **SP3 → COM** terminal way on the terminal block and tighten the screw.
- d. Repeat operations a. to c. for connecting the Alarm 4 cable to the SP4 terminals.
- e. Check that the wiring has been completed correctly.
- f. Push the terminal block firmly back into the **ALARMS** socket.

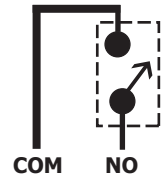

2.4.2.5 RS485 Port Connection

The RS485 connection is a push-fit socket labelled **COMMS** as shown in *Figure 9*.

The method of connection is as follows:

Pin Number	Function
2	B
3	A
5	0V

- a. Check the orientation of the RS485 connector and gently push it into the socket.
- b. Tighten the two screws on the connector.

2.4.3 Sensor Assembly Wiring

NOTE: If the analyzer has been ordered with a sampling system, the Liquidew I.S. sensor assembly will be factory-wired to the junction box. In that case disregard the following instructions and go to Section 3.

2.4.3.1 Dew-point Transmitter Wiring



HAZARDOUS AREA INFORMATION

The dew-point transmitter (Easidew PRO I.S.) is certified intrinsically safe for use in hazardous areas.

Before using the Easidew PRO I.S. in any hazardous environment ensure that personnel are completely familiar with the above standards relating to the certification of this instrument and also with the further information relating to intrinsically safe apparatus to be found in standard EN60079-14:1997 or equivalent, and up-to-date codes of practice in the country of installation.

Installation of the Easidew PRO I.S. **MUST** be as per system drawing in order to comply with the intrinsic safety regulations.

Refer to ATEX/**QPS**/IECEX certificates for the dew-point and temperature transmitters' connection cable requirements which stipulate maximum permissible mutual capacitance and inductance to resistance ratio.

Preparation of the Sensor Cable



In order to comply with hazardous area certification of the product it is essential that the crimps/wire ferrules supplied must be attached on to any cable installed into the connector.

- a. As shown in *Figure 15* below, the crimps/wire ferrules should be applied so that there is no possibility of a conductor strand of a core becoming free.

When the crimp/wire ferrules are applied they should have a minimum of two positions of crimping. After the crimp/wire ferrules are applied they should be trimmed to a length of 5mm (0.2") (see *Figure 16*).

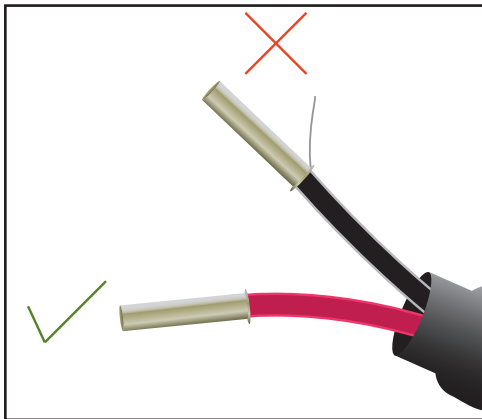

Figure 15 *Crimped Wires*

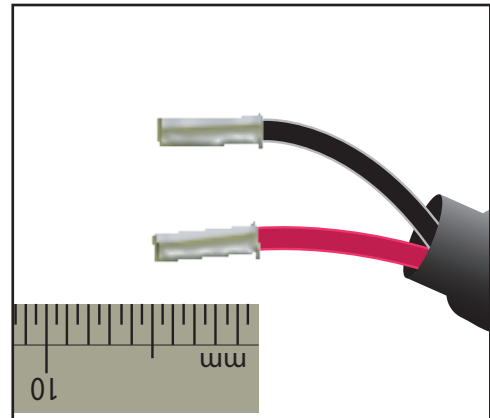

Figure 16 *Cut to 5mm*

- b. Cable connection to the dew-point transmitter is made via the terminal block (4) (see *Figure 17*). Remove the terminal housing lid (2) to access.

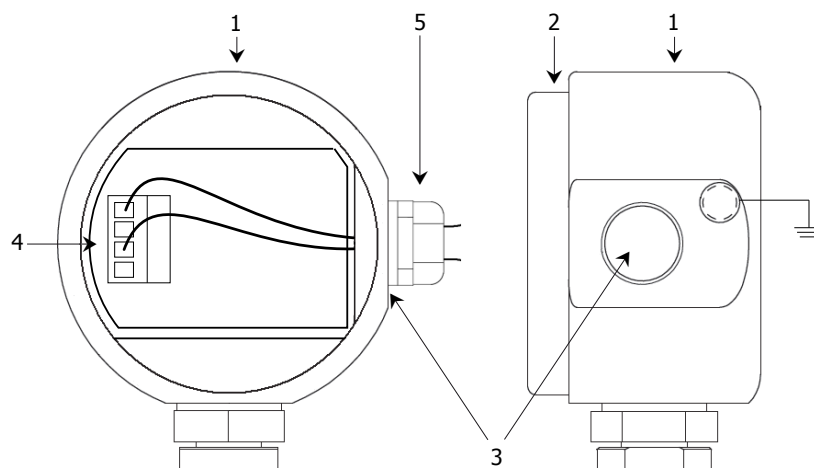

Figure 17 *Dew-Point Transmitter Housing*

- c. Ensure that the outer diameter of the selected cable is matched to an EExe M20 cable gland (5). Unscrew the cable gland (5) and slide the cable through the cable gland (5) and into the terminal housing (1) through the cable entry (3).
- d. Remove the terminal block (4) from the PCB for easier operation. Connect the signal cable leads with the crimps/wire ferrules to the screw terminals on the terminal block (4) in accordance with the following pin-assignment drawing.

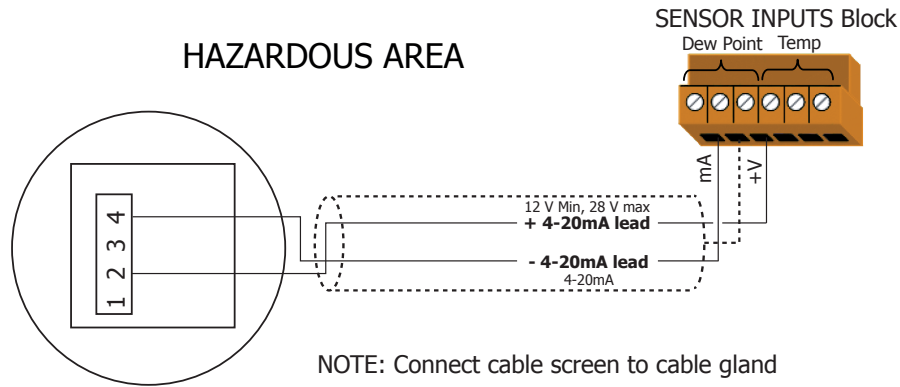

Figure 18 Dew-Point Transmitter Pin Assignment Drawing



Always connect the 4...20 mA return signal to a suitable load (in this case, back into the control unit) before the power is applied. Without this connection the transmitter may be damaged if allowed to operate for prolonged periods. The maximum load is 500 Ω at 24 V or 250 Ω at 12 V.

When the crimps/wire ferrules are installed into the connector terminal block ensure that they are inserted completely. When all wire connections are made, ensure that there is a minimum clearance distance of 2mm (0.008") between each terminal.

- e. Press the terminal block (4) back into its socket firmly.
- f. Tighten the cable gland (5) around the cable. Ensure that the sealing is not damaged and that the cable gland and seals are assembled correctly in order to ensure ingress protection.
- g. Install and tighten the terminal housing lid (2).

2.4.3.2 Temperature Transmitter Wiring

HAZARDOUS AREA INFORMATION

The temperature transmitter is certified intrinsically safe for use in Hazardous areas by TRL and is covered by EC-Type examination certificate TRAC09ATEX11232X. The instrument conforms to the standards EN60079-0:2006, En60079-11:2007, EN60079-26:2007, EN61241-0:2006, EN61241-11:2006 certification code II 1 G Ex ia IIC T4 Ga, Ex iaD 20 T135 °C Da, Tamb -20 °C to +85 °C



Before using the temperature transmitter in any hazardous environment, ensure that personnel are completely familiar with the above standards relating to the certification of this instrument and also with the intrinsically safe apparatus information in EN60079-14:1997 or equivalent codes of practice in the country of installation.

If the temperature transmitter is not ordered together with the analyzer, it is the user's responsibility to make sure that the temperature transmitter is compatible with the I.S. barrier in the control unit.

Refer to ATEX/QPS/IECEx certificates for the dew-point and temperature transmitters' connection cable requirements which stipulate maximum permissible mutual capacitance and inductance to resistance ratio.

- a. Cable connection to the temperature transmitter is made via the terminal block (4) accessed by removing the terminal housing lid (2) (Figure 19).

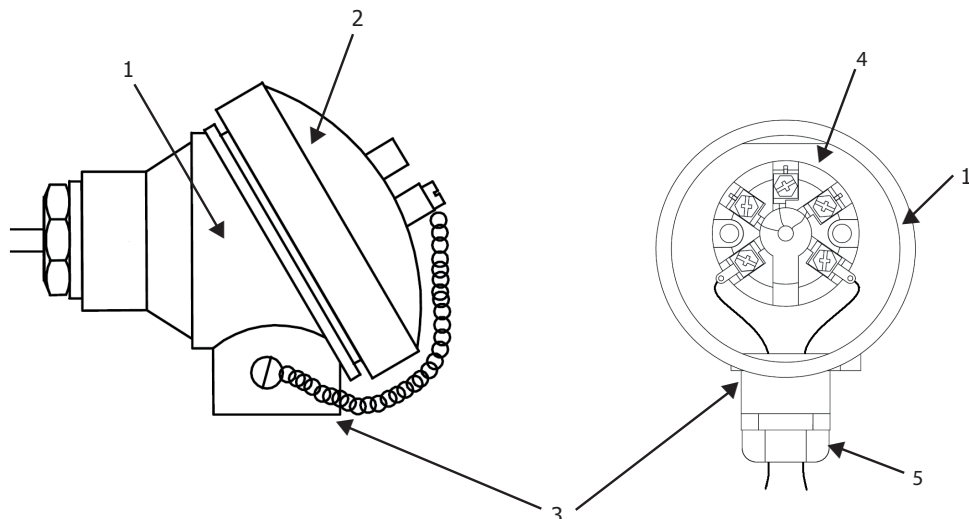

Figure 19 Temperature Transmitter Housing

- b. Ensure that the outer diameter of the selected cable is matched to an EExe M20 cable gland (5). Unscrew the cable gland (5) and slide the cable through the cable gland (5) and into the terminal housing (1) through the cable entry (3).

- c. Connect the signal cable leads to the terminals on the terminal block (4) in accordance with the following pin-assignment drawing. Pin designations are marked adjacent to each pin.

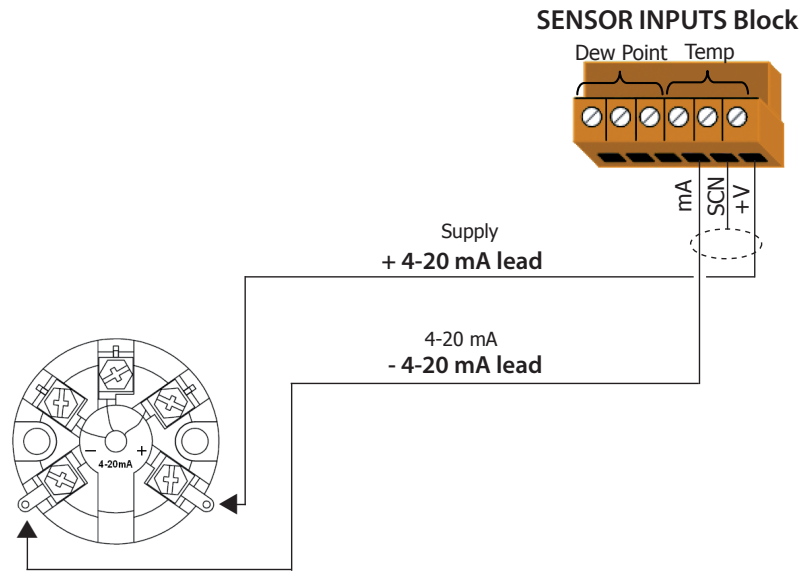

Figure 20 *Temperature Transmitter Pin Assignment Drawing*

- d. Tighten the cable gland (5) around the cable. Ensure that the sealing is not damaged and that the cable gland and seals are assembled correctly in order to ensure ingress protection.
- e. Install and tighten the terminal housing lid (2).

3 OPERATION

3.1 Preparation



Before applying power and beginning sample flow ensure that the system has been properly installed following the instructions in Section 2 and that all sample connections are tight and leak free. Check that the wiring has been correctly completed.

Ensure that personnel are familiar with Sections 1, 2 and 3 of this manual in which the equipment controls, indicators, elements of the display and overall menu structure are described, before starting operation.

Prior to operation, the instrument must be connected to the correct electrical power supply, sensor signal input, relevant analog and alarm outputs as described in Section 2.

On delivery, the instrument will have been set-up with a standard set of default parameters defining the operation of the analyzer. These parameters can be changed as required by means of the Set-up menus.

3.2 Start-Up

3.2.1 Function Keys Activation

There are five push-button function keys on the user interface of the control unit. They can be locked to prevent unauthorized operation or accidental pressing. The lock switch is located on the back panel of the control unit (see *Figure 9*). It must be switched to the **OFF** position to activate the function keys.

NOTE: Remember to lock the function keys after each operation.

3.2.2 Powering-up the Analyzer

For the AC power supply version of the Liquidew I.S., turning on the power switch on the back panel of the control unit will power-up the control unit and the two transmitters.

There is no power switch for the DC power supply version. It is turned on automatically once 24 V DC power source is applied.

After turning on the analyzer the display will be illuminated. The default main reading page displays sample temperature (°C) and sample dew point (°C).

It is possible to change the display unit of the Main Reading Page using the **Display** key (see Section 1.4.1). At the default screen, pressing the **Display** key will change the units of measurement readings in sequence as shown below:

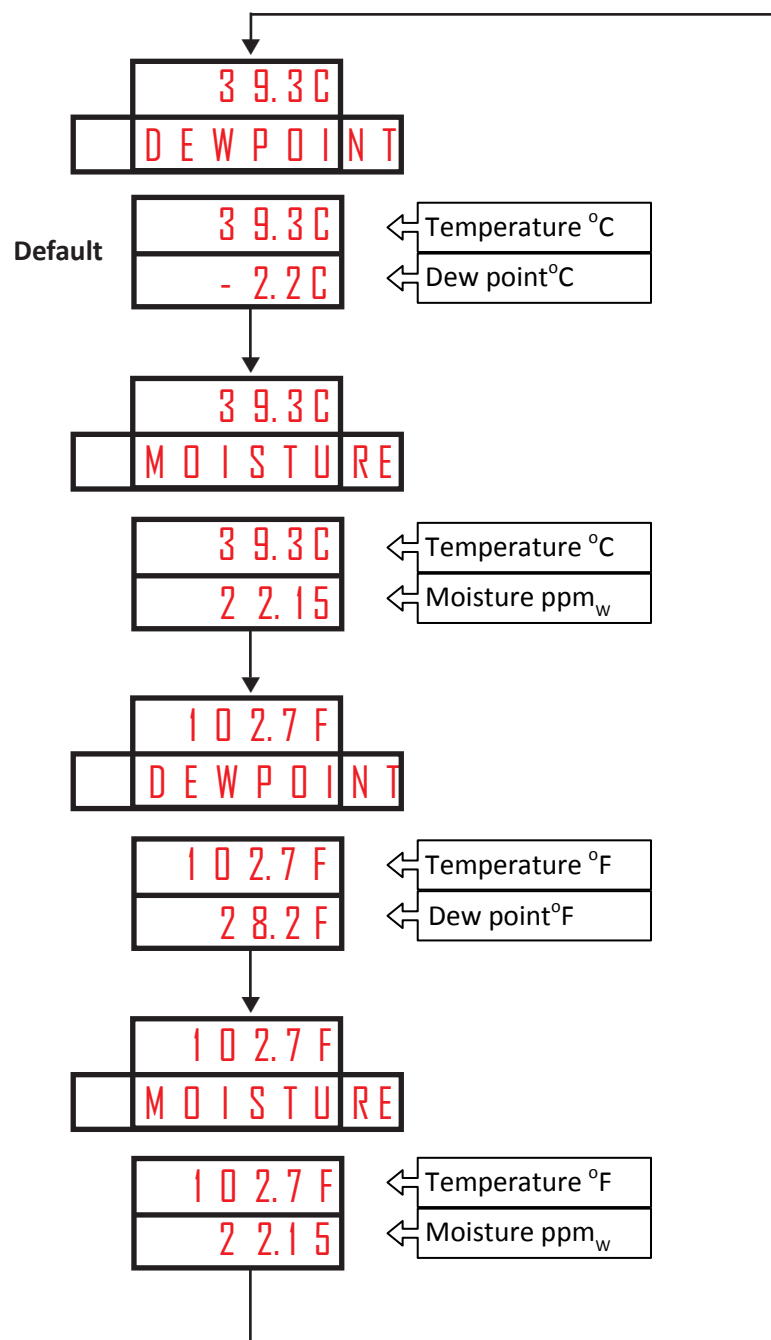

Figure 21 Units of Measurement Readings in Sequence

Whenever the **Display** key is pressed, the bottom line of the display will scroll once with the new moisture measurement unit (Moisture/Dew Point) before it shows the readings.

NOTE: After the display units are set they will remain the same even if the analyzer power is turned off and on again.

NOTE: The changing of the units at the Main Reading Page will change the units in OUTPUT SETUP and FAULT SETUP automatically. It will not affect the ALARM SETTINGS.

3.2.3 Sample Flow Start-Up

Follow the Liquidew I.S. Premium Sampling System Instructions to establish the sample flow of:

0.1...0.3 l/min (0.026...0.079 GPM)

If the Liquidew I.S. Analyzer is to be fitted to a non-Michell sampling system, the sample requirements listed in Section 1.5 must be fulfilled.

3.3 Menu Structure

The Liquidew I.S. main menu has a two level menu structure. There are three sub-menus - LIQUID SETUP, OUTPUT SETUP and FAULT SETUP. The ALARM SETTINGS are not in the main menu and are accessed separately. These are described in detail in following sections. Below is the complete menu structure:

NOTE: ● represents the Main Reading Page

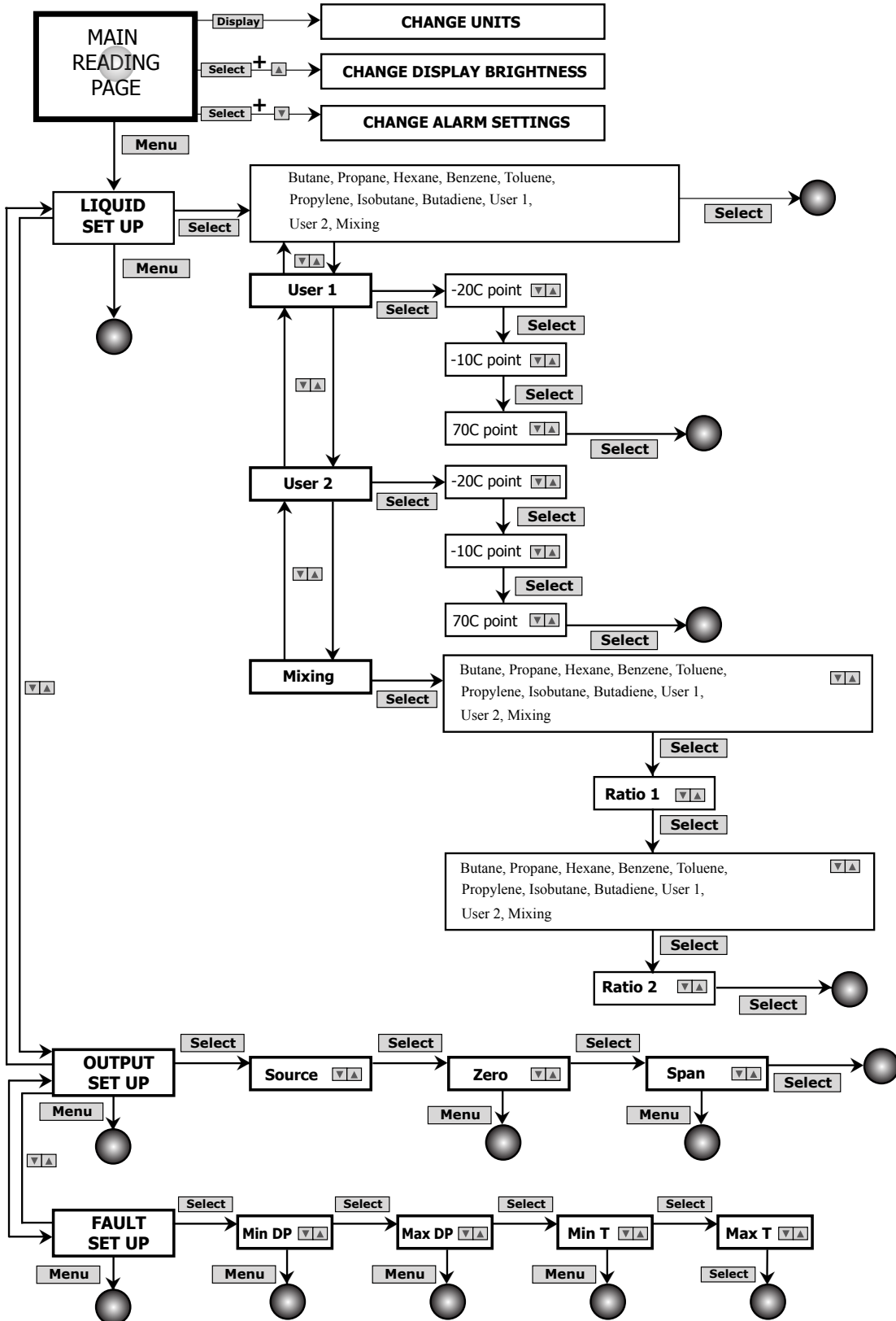

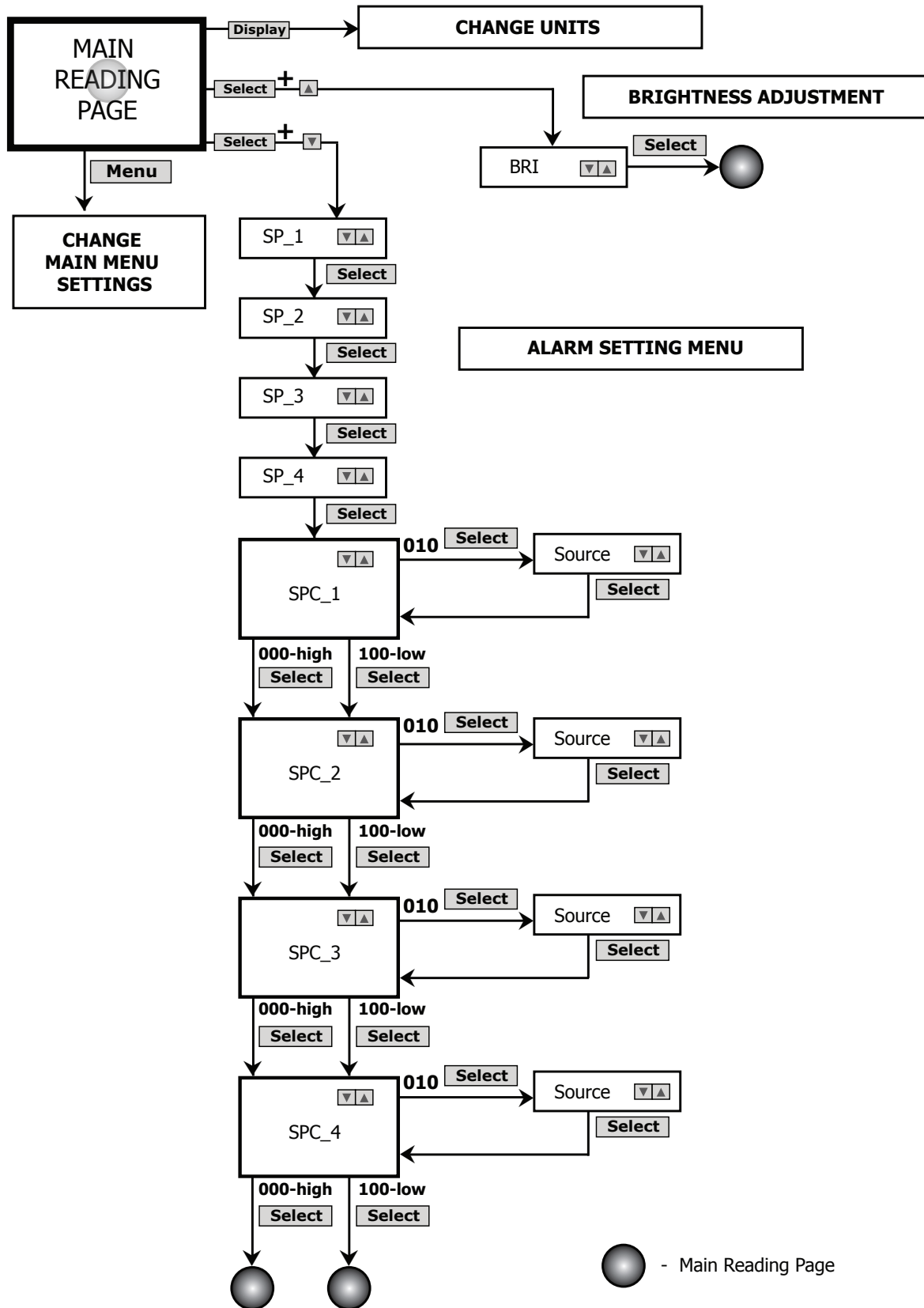

Figure 22 Menu Maps

3.4 Main Reading Page

The Main Reading Page is the default screen shown after turning the instrument on. It will display the units of measurement selected by the user (see Section 3.2.2).

3.5 Liquid Set-Up

The saturation concentration C_s values of the sample liquid need to be specified for calculation from the measured water dew point ($^{\circ}\text{C}/^{\circ}\text{F}$), and the sample temperature ($^{\circ}\text{C}/^{\circ}\text{F}$), to the moisture content (ppm_w) using Henry's Law. With the Liquidew I.S. there is a list of liquids with pre-set C_s values for calculation. Solubility data for 8 solutes are pre-programmed, plus two selections for user-configured C_s values to be entered, and one possibility to set a mixing ratio of two of the 8 pre-set and two configurable solutes.

Liquid Name	Displayed Name
Butane	N-BUTANE
Propane	N-PROPANE
Hexane	N-HEXANE
Benzene	BENZENE
Toluene	TOLUENE
Propylene	PROP-1-ENE
Isobutane	I-BUTANE
Butadiene 1,3	BUTADIENE-1-3
User 1	USER 1
User 2	USER 2
Mixing	MIXING

Table 1 Liquid List

3.5.1 Liquid Selection

From the Main Reading Page, press the **Menu** key to enter the main menu. The first setting option is:

```

LIQUID
SETUP

```

Press the **Select** key to enter this sub menu. The display will show the name of the currently selected liquid. The factory default setting is Butane. The full name of the liquid will scroll across the bottom line of the display.

```

N - BUTA
N - BUTA N E

```

- Change the selection by scrolling through the liquid list using the **▲** and **▼** keys.
- When the desired liquid is shown on the display, press the **Select** key to confirm. The display will then return to the Main Reading Page and the calculations will then be based on the selected liquid.

NOTE: The next time the 'LIQUID SETUP' sub menu is entered it will go directly to the currently selected liquid.

3.5.2 User-Defined Liquid

If the process liquid is not listed the user can define their own liquid solubility profile by entering the C_s value (10 pre-set temperature points, over the range 0...+60 °C (32...+140 °F)) for that particular liquid. There are two user-defined liquids available and these are named USER 1 and USER 2.

- a. In the liquid list in the 'LIQUID SETUP' sub menu, use the ▲ and ▼ keys to scroll to:



User-defined liquids are found near to the end of the list.

- b. Press the **Select** key to access the C_s value table and define the solubility profile of this liquid. The first temperature point for the C_s value is at 0 °C.

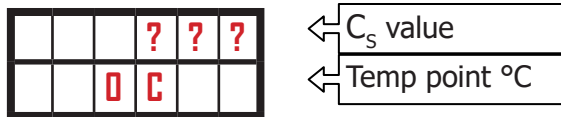

- c. Use the ▲ and ▼ keys to adjust the C_s value.
- d. Press the **Select** key to confirm. The display will then display the next temperature point, -10 °C.

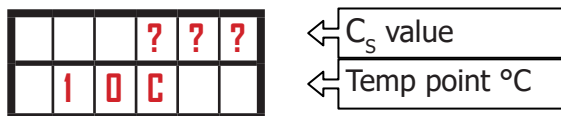

- e. Follow steps c. and d. to enter the C_s value for the 10 °C temperature point, and then repeat for 20 °C, 30 °C, 40 °C, 50 °C, 60 °C. If C_s values are not available for temperature points outside of expected measurement conditions then enter an estimated value (extrapolated by drawing a curve in such cases).
- f. After entering the C_s value for the 60 °C temperature point, press the **Select** key to confirm. The display will then return to the Main Reading Page, and calculations will then be based on the USER 1 solubility profile.

For the second user-defined liquid USER 2, the solubility profile can be entered in USER 2, following the above procedure:



3.5.3 Liquid Mixing

The user can define the solubility profile for a liquid by mixing any two liquids from the liquid list, including USER 1 and USER 2, with an editable ratio.

- a. In the liquid list in the **LIQUID SETUP** sub menu, use the ▲ and ▼ keys to scroll to:

M	I	X	I	N	G		
		M	I	X	I	N	G

This is the last option in the list.

- b. Press the **Select** key to enter another liquid list and select the first liquid to be mixed. The display will show the name of the currently selected first liquid. The full name of the liquid will scroll across the bottom line of the display.

P	R	O	P	A	N		
	P	R	O	P	A	N	E

- c. Change the selection by scrolling through the list using the ▲ and ▼ keys.
- d. When the required liquid is on the display, press the **Select** key to confirm. The display will then show the mixing ratio for this selected first liquid.

			0.	2	5
R	A	T	I	O	I

- e. Use the ▲ and ▼ keys to adjust the ratio.
- f. Press the **Select** key to confirm. The liquid list will be displayed again with the name of the currently selected second liquid. The full name of the liquid will scroll across the bottom line of the display.

B	E	N	Z	E	N		
	B	E	N	Z	E	N	E

- g. Change the selection by scrolling through the list using the ▲ and ▼ keys.
- h. When the required second liquid is on the display press the **Select** key to confirm. The display will then show the mixing ratio for this selected second liquid.

			0.	7	5
R	A	T	I	O	2

This mixing ratio for the second liquid cannot be adjusted, as it is depends on the ratio for the first liquid (Ratio 2 = 1 – Ration 1).

- i. Press the **Select** key to return to the Main Reading Page. Calculations will then based on the defined MIXING solubility profile.

NOTE: Follow Section 3.5.2 to define the USER 1 / USER 2 solubility profile first if you want to select them for mixing.

NOTE: The next time liquid mixing is entered it will go directly to the currently selected liquid.

3.6 Analog Output 1 (Moisture Content or Dew Point - User-Selectable)

The source and scale of the 4...20 mA output can be configured in the **OUTPUT SETUP** menu.

From the Main Reading Page, press **Menu** to enter the main menu. Use the **▲** key to scroll to the **OUTPUT SETUP** option.

O	U	T	P	U	T
S	E	T	U	P	

3.6.1 Output Source Selection

Press **Select** to enter the **OUTPUT SETUP** sub menu. The first parameter is the mA output signal source. The display will then change to the name of the currently selected source. The full name of the output source will scroll across the bottom line of the display.

	M	O	I	S	T
S	O	U	R	C	E

	M	O	I	S	T		
M	O	I	S	T	U	R	E

The user can select moisture signal, dew-point signal, or temperature signal as the output source.

- Change the selection by scrolling through these three options using the **▲** and **▼** keys.
- When the required source is shown on the display, press the **Select** key to confirm. The 4...20 mA output will then switch to the selected source. The display will then change to the next parameter, the ZERO point of the output range.

3.6.2 Output Range ZERO Value Settings



- Use the ▲ and ▼ keys to adjust the **ZERO** value.
- Press the **Select** key to confirm. The display will then change to the next parameter, the **SPAN** point of the output range.

NOTE: The output range **ZERO** value will be in ppm_w, dew point or temperature, depending on the specific source (moisture signal, dew-point signal or temperature signal) selected in Section 3.6.1. Also, if it is in temperature or dew point, it could be either C(°C) or F(°F) depending on the unit selection in the Main Reading Page (refer to Section 3.2.2). The value will be automatically converted based on the new units selected.

3.6.3 Output Range SPAN Value Settings



- Use the ▲ and ▼ keys to adjust the **SPAN** value.
- Press the **Select** key to confirm. The display will then return to the Main Reading Page.

NOTE: The output range **SPAN** value will be in ppm_w, dew point or temperature, depending on the specific source (moisture signal, dew-point signal or temperature signal) selected in Section 3.6.1. Also, if it is in temperature or dew point, it could be either C(°C) or F(°F) depending on the unit selection in the Main Reading Page (refer to Section 3.2.2). The value will be automatically converted based on the new units selected.

3.7 Analog Output 2 (Sample Temperature - Only)

Analog Output 2 has a fixed temperature signal of -20 °C...+70 °C (-4 °F...+158 °F) and cannot be configured.

3.8 System Fault Alarm Set-Up

There are four conditions for the system fault alarm which can be configured in the **FAULT SETUP** sub menu. **NOTE:** If any of the fault alarm conditions occur during system operation **Analog output 1** will rise to 21 mA for both high and low errors. **Analog output 2** will go to 3 mA for a low error and 21 mA for a high error. This fault alarm state is continuous for the duration during which the dew point or temperature are out of limits. This alarm state is automatically re-set when normal operation resumes.

From the Main Reading Page press the **Menu** key to enter the main menu. Use the **▲** key to scroll to the **FAULT SETUP** option.

F	A	U	L	T
S	E	T	U	P

3.8.1 Minimum Dew-Point Value for the Fault Alarm

Press the **Select** key to enter the **FAULT SETUP** sub menu. The first parameter is the minimum dew-point value.

-	1	0	0.	0	C
M	I	N	_	D	P

- Use the **▲** and **▼** keys to adjust the minimum dew-point value.
- Press the **Select** key to confirm. The display will then show the second fault alarm parameter which is the maximum dew-point value.

NOTE: The units will be either C(°C) or F(°F) depending on the unit selection in the Main Reading Page (refer to Section 3.2.2). The value will be converted automatically based on the new units selected.

3.8.2 Maximum Dew-Point Value for the Fault Alarm

		2	0.	0	C
M	A	X	_	D	P

- Use the **▲** and **▼** keys to adjust the maximum dew-point value.
- Press the **Select** key to confirm. The display will then show the third fault alarm parameter which is the minimum temperature.

NOTE: The units will be either C(°C) or F(°F) depending on the unit selection in the Main Reading Page (refer to Section 3.2.2). The value will be converted automatically based on the new units selected.

3.8.3 Minimum Temperature Value for the Fault Alarm

			0.	0	C
M	I	N	_	T	

- Use the ▲ and ▼ keys to adjust the minimum temperature value.
- Press the **Select** key to confirm. The display will then show the fourth fault alarm parameter which is the maximum temperature value.

NOTE: The units will be either C(°C) or F(°F) depending on the unit selection in the Main Reading Page (refer to Section 3.2.2). The value will be converted automatically based on the new units selected.

3.8.4 Maximum Temperature Value for the Fault Alarm

		5	0.	0	C
M	A	X	_	T	

- Use the ▲ and ▼ keys to adjust the maximum temperature value.
- Press the **Select** key to confirm. The display will then return to the Main Reading Page.

NOTE: The units will be either C(°C) or F(°F) depending on the unit selection in the Main Reading Page (refer to Section 3.2.2). The value will be converted automatically based on the new units selected.

3.9 Alarm Setting

There are 4 built-in alarm relays which can be configured independently. From the Main Reading Page, press and hold the **Select** key then press the **▼** key to enter the 'ALARM SETTING' page.



3.9.1 Alarm Set-Point Adjustment

The first page, as shown above, in 'ALARM SETTING' is for adjusting the Set-Point of Alarm Relay 1.

- Use the **▲** and **▼** keys to adjust the set-point.
- Press the **Select** key to confirm. The display will then show the Alarm Set-Point for Alarm Relay 2.
- Repeat steps (a) and (b) to adjust the set-point for Alarm Relay 2, Alarm Relay 3 and Alarm Relay 4 accordingly.
- After Alarm Set Point SP_4 for Alarm Relay 4 is set, press the **Select** key to confirm. The display will then show the Alarm Control Setting Page SPC_1 for Alarm Relay 1.

NOTE: The Alarm Set Point could be in ppm_w, dew point (°C/°F) or temperature (°C/°F) depending on the source selection for the specific alarm (this can be set in SPC function). Details of selecting the alarm source are explained in Section 3.9.3. It should not be affected by unit selection at the Main Reading Page, or source selection of the 4...20 mA output under OUTPUT SETUP.

3.9.2 Alarm Type Selection

The alarm type can be selected in the Alarm Control Setting page.

From the Main Reading Page, press and hold the **Select** key then press the ▼ key to enter the 'ALARM SETTING' page. Press the ▼ key until SPC_1 is shown.

The alarm can be activated above or below the Alarm Set Points by setting the control code.



- a. Use the ▲ and ▼ keys to adjust the control code.
 - Code **000**: Alarm type high. Activates the alarm when the measurement value is above Alarm Set Point SP_1
 - Code **100**: Alarm type low. Activates the alarm when the measurement value is below Alarm Set Point SP_1
- b. Press the **Select** key to confirm. The display will then change to the Alarm Control Setting for Alarm Relay 2.
- c. Repeat steps (a) and (b) to adjust the type (high/low) for Alarm Relay 2, Alarm Relay 3 and Alarm Relay 4 accordingly.

3.9.3 Alarm Source Selection

The alarm source can be also selected in the Alarm Control Setting page.

From the Main Reading Page, press and hold the **Select** key then press the ▼ key to enter the 'ALARM SETTING' page. Press the ▼ key until SPC_1 is shown.

The user can select **RESULT** (moisture), **DP_C** (dew point °C), **TEMP_C** (temperature °C), **DP_F** (dew point °F) or **TEMP_F** (temperature °F) as the alarm source. **Other options like DISP and TOT_1 in the list are for factory settings only and should not be changed.**

- a. Use the ▲ and ▼ keys to adjust the control code to 010



- b. Press the **Select** key to confirm this control code. The display will then change to the Alarm Source Selection sub menu.



- c. Change the selection by scrolling through these options using the ▲ and ▼ keys.
- d. When the required source is shown on the display, press the **Select** key to confirm. The alarm will then switch to the selected source. The display will then return to the Alarm Control Setting page.



- e. Use the ▲ and ▼ keys to change the control code back to 000 or 100 depending on the alarm type (high/low).
- f. Press the **Select** key to confirm. The display will then change to the Alarm Control Setting page for Alarm Relay 2.
- g. Repeat the same operation to adjust the set-point for Alarm Relay 2, Alarm Relay 3 and Alarm Relay 4 accordingly.
- h. After Alarm Relay 4 is configured, press the **Select** key to return to the Main Reading Page.

CAUTION: The Alarm Set-Point value will NOT be converted automatically based on the new alarm source selected. In some cases, the operation to change the alarm source may trigger the alarm. For example: If the SP_1 is set at 10°C dew point - when the alarm source is changed from DP_C (°C dew point) to DP_F (°F dew point) under SPC_1, the value of SP_1 will be 10°F.

3.10 Display Brightness Adjustment

The brightness of the display can be adjusted from the 'BRIGHTNESS ADJUSTMENT' page. From the Main Reading Page, press and hold the **Select** key then press ▲ to enter the 'BRIGHTNESS ADJUSTMENT' page.



- a. Use the ▲ and ▼ keys to adjust the display brightness.
- b. Press the **Select** key to confirm the adjustment. Press the **Select** key again to return to the Main Reading Page.

Appendix A

Technical Specifications

Appendix A Technical Specifications

Sensors	
Sensor Technology	Michell Ceramic Moisture Sensor
Sensor Version	Easidew PRO I.S.
Measurement Range	0.001...1000 ppm _w Higher range on request Actual range dependent on solubility of sample fluid
Calibration Range	-100...+20 °Cdp (-148...+68 °Fdp)
Accuracy	Dew point: ±1 °C between -59.9 & +20 °Cdp (±1.8 °F between -75.9...+68 °Fdp) ±2 °C between -60 & -100 °Cdp (±3.6 °F between -76...-148 °Fdp)
	Moisture content: ±10% of reading ±20% of reading
Resolution	0.1 °C between +20 and -100 °Cdp (+68 and -148 °Fdp)
Temperature Measurement	Pt100
Temperature Measurement Range	-20...+70 °C (-4...+158 °F)
Temperature Measurement Accuracy	Accuracy ±0.2 °C
Analysis Pressure	Up to 5 MPa (50 barg / 725 psig)
Analysis Temperature	0...+50 °C (32...+122 °F)
Sample Flow Rate	Min 0.01 l/min (0.003 GPM), Max 10 l/min (2.64 GPM) 0.1...0.3 l/min (0.026...0.079 GPM) recommended
Calibration	Traceable to British (NPL) and American (NIST) National Humidity Standards
Control Unit	
Display	Two line 6-digits LED, displaying moisture content / dew point (user toggle) and temperature
Analog Output	Two 4...20 mA (max load 500 Ω) - user configured for parameter, unit and range. Output 1 = 21 mA when a high or low error occurs. Output 2 = 3 mA for a low error and 21 mA for a high error.
Digital Output	RS485 Modbus RTU
Display Mode	Moisture content (ppm _w) Dew point (°C or °F) Temperature (°C or °F)
Display Resolution	0.1 °Cdp, 0.1 °Fdp, 0.01 ppm _w 0.1 °C temp
Alarms	Four alarm relays. Control action and set-point are user programmable Two Form C contacts rated 10A / 240 V AC or 8A / 24 V DC Non-inductive load Two Form A contacts rated 5A / 240 V AC or 4A / 24 V DC Non-inductive load
I.S. Barriers	Galvanic isolation type, integrated to Control Unit
Power Supply	85...265 V AC 47/63Hz or 10...72 V DC 10 W max power consumption

Enclosure	19" sub rack unit Dimensions: 132 x 483 x 375mm (5 x 19 x 14.75") (h x w x d) (100mm (4") minimum rear clearance depth for cables and vents)
Operating Environment	Indoor, safe area, 0...+50 °C (+32...+122 °F), < 90% RH
Premium Sampling Systems	
Enclosure	304 stainless steel (EN1.4301) enclosure Option for complete enclosure in 316 stainless steel (EN1.4401) All fixtures stainless steel Galvanized steel internal mounting plate Open panel version available for indoor installation Dimensions 800 x 600 x 300mm (31.5 x 23.6 x 11.8") (h x w x d)
Enclosure Mounting	Stainless steel wall mounting brackets
Enclosure Ingress Protection	IP66
Enclosure Temperature Control	Heater/thermostat options for fixed set-point +20 °C (+68 °F) or adjustable set-point range 0 to control +50 °C (+32...+122 °F)
Heater Power Supply	110/120 or 220/240/255 V AC, 47/63 Hz Power consumption 100 W max
Operating Environment	Shaded position, on or off shore, -20...+40 °C (-4...+104 °F) (-40...+60 °C (-40...+140 °F) max transient) Enclosure cooling option recommended for climate ambient > +45 °C (+113 °F)
Sample Cooling Option	Recommended for process fluid temperatures > +40 °C (+104 °F) Plant water supply required ≤ +30 °C (+86 °F)
Hazardous Area Certification	
Certification Codes	See Appendix D

A.1 Dimensional Drawings

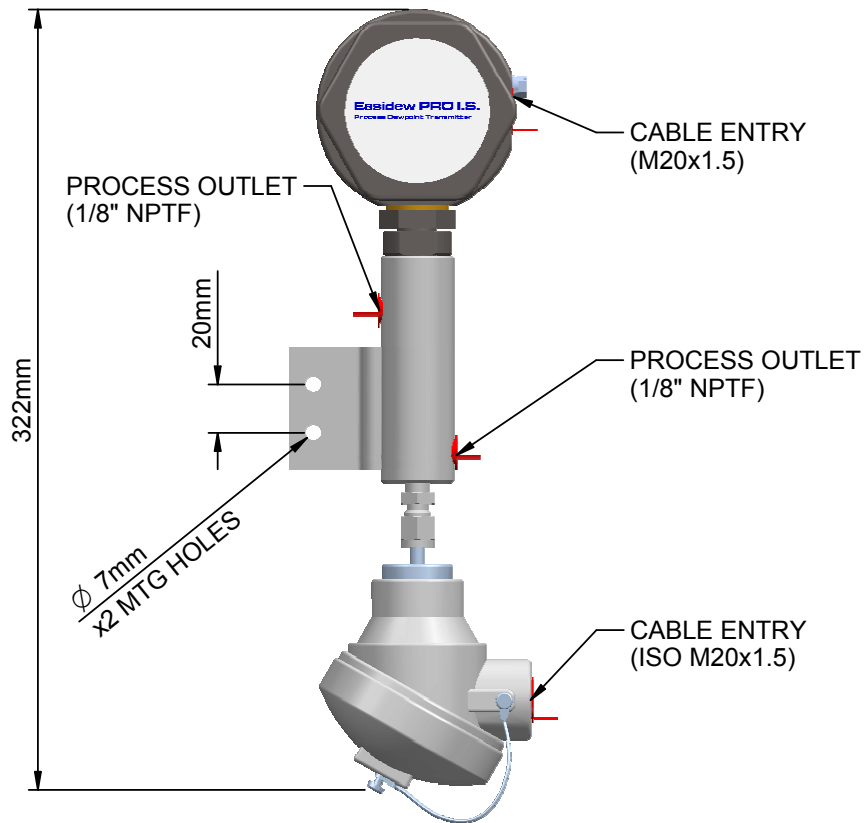
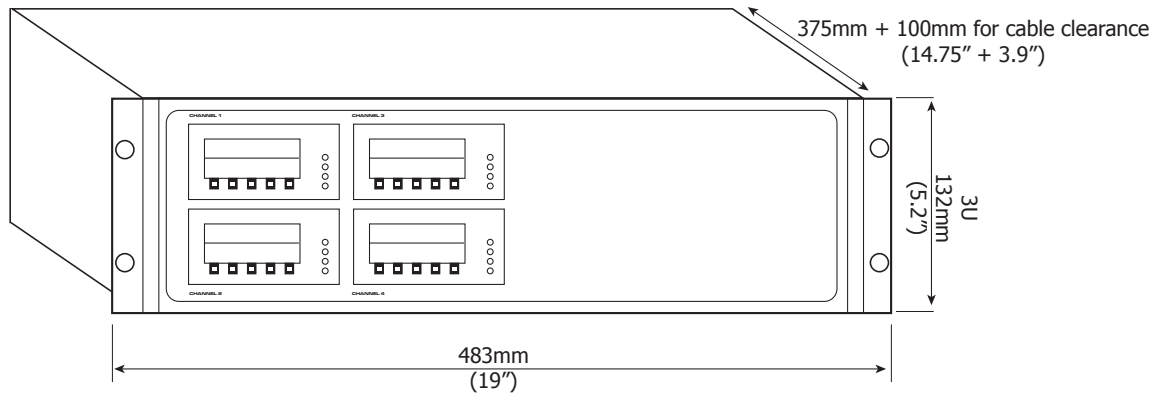

Figure 23 Dimensional Drawings

Appendix B

Serial Communications

Appendix B Serial Communications

To communicate with the monitor:

- Connect to the serial port using the wiring defined below.
- Set the address of the monitor using the front panel.
- Set the desired communication protocol (ASCII or Modbus RTU) via the front panel or over the serial interface.
- Determine the register number of the parameter to be read.
- Send the correct command to the monitor and decode the response.

RS485 Wiring

The Liquidew I.S. monitor uses a 2-wire RS485 connection.

Pin Name	Liquidew DB9 Pin
A	3
B	2
GND	5

Pin numbers in the manual refer to standard pins on the DB9 D-Sub connector on the rear panel of the MCU:

Male DB9 Pinout (Liquidew I.S. Monitor on MCU Panel)

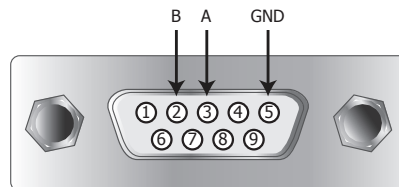

It will be necessary to match up the A/B (Differential data pair) and GND (0 V) pins with the wiring of your own third party adaptor.

E.g. For the K3-ADE RS232->RS485 adaptor use the following wiring:

Pin Name	Liquidew DB9 Pin	K3-ADE DB9 Pin
A	3	8
B	2	3
GND	5	5

This wiring is the generally accepted standard for most 2-wire RS485 equipment.

Setting the Address of the Monitor

This procedure needs to be done for either ASCII or MODBUS RTU protocols.

- a. Press the **Select** and **▲** keys simultaneously to display the BRI (brightness) menu.
- b. Press the **Select** key again to display the CAL (calibration) menu.
- c. Use the **▲** and **▼** keys to set the code in the CAL menu to **200**.
- d. Press the **Select** key 3 times to display the address.
- e. Use the **▲** and **▼** keys to set the address.
- f. Press the **Select** key again and use the **▲** and **▼** keys to set the code in the CAL menu to **000**.

Setting the Communications Protocol

- If the instrument is set to ASCII send **sw132,1\$** to set to Modbus.
- If the instrument is set to Modbus send **0** to register 40132(132) to set to ASCII.

Using the Front Panel

Firstly, follow the instructions in Appendix C to unlock the CODE settings on the monitor front panel.

- a. Press the **Select** and **▲** keys simultaneously to display the BRI (brightness) menu.
- b. Press the **Select** key until the CODE3 menu is displayed and set it to **001** using the **▲** and **▼** keys. Setting CODE3 to **000** sets the communications back to ASCII.
- c. Press the **Select** key to exit the menu.

NOTE: It is now recommended that the CODE settings are locked again using the instructions in Appendix C, as accidental modification of the CODEs can cause damage to the monitor.

Register Map:

Function	Register Name	Texmate ASCII	Modbus RTU
MOISTURE	RESULT	254	40515/40516
DEWPOINT_C	CH1	253	40517/40518
TEMPERATURE_C	CH2	252	40519/40520
DEWPOINT_F	CH3	251	40521/40522
TEMPERATURE_F	CH4	250	40523/40524
LAST_VIEW	TOTAL1	16	40529/40530
INPUT_VALUE	TOTAL2	17	40531/40532
cur_table	USER_MEMORY_1	5121	45121
UpdateFlag	USER_MEMORY_3	5123	45123
MIN_DP	USER_MEMORY_4	5124	45124
MAX_DP	USER_MEMORY_5	5125	45125
MIN_TEMP	USER_MEMORY_6	5126	45126
MAX_TEMP	USER_MEMORY_7	5127	45127
COMPOUND_1	USER_MEMORY_10	5130	45130
RATIO_1	USER_MEMORY_11	5131	45131
COMPOUND_2	USER_MEMORY_12	5132	45132
RATIO_2	USER_MEMORY_13	5133	45133
OP_SOURCE	USER_MEMORY_15	5135	45135
FAULT_OUTPUT	SP5_RESET_VALUE	119	40643/40644
SETPOINT_1	Alarm Set Point 1	6	40535/40536
SETPOINT_2	Alarm Set Point 2	7	40537/40538
SETPOINT_3	Alarm Set Point 3	8	40539/40540
SETPOINT_4	Alarm Set Point 4	9	40541/40542

ASCII Communications

Start Character	Address	Read/Write	Register Address	Separator	Data Value	Message Terminator
s	0 to 255	r or w	1 to 65535	,	-9999999 to 9999999	\$

- Reading the dew-point value from a meter that has an address of 2:
Send: s2r253\$
- Reading the LBMMSCF from a meter that has an address of 5:
Send: s5r244\$

MODBUS RTU

Once the protocol has been set the monitor will communicate in accordance with the standard Modbus RTU protocol.

The **Read Holding Registers** command should be used to read the registers listed in the register map. When two registers are listed in the table both registers must be read using a single command.

Note that the least significant word is sent first, for example - for dew point - register 40517 is the least significant word and 40518 is the most significant word.

It should also be noted that the actual address is that stated, minus 40000, i.e. 40517 is physically 517.

Example: Getting the dew-point value using Modbus RTU

Register Numbers:

Function	Register Name	Texmate ASCII	Modbus RTU
BARG	RESULT	254	40515/40516
Dew Point_C	CH1	253	40517/40518
psig	CH2	252	40519/40520

There is often an offset of -1 for the register address, depending on your software/PLC system. To read the dew-point value software, read holding registers 516-517:

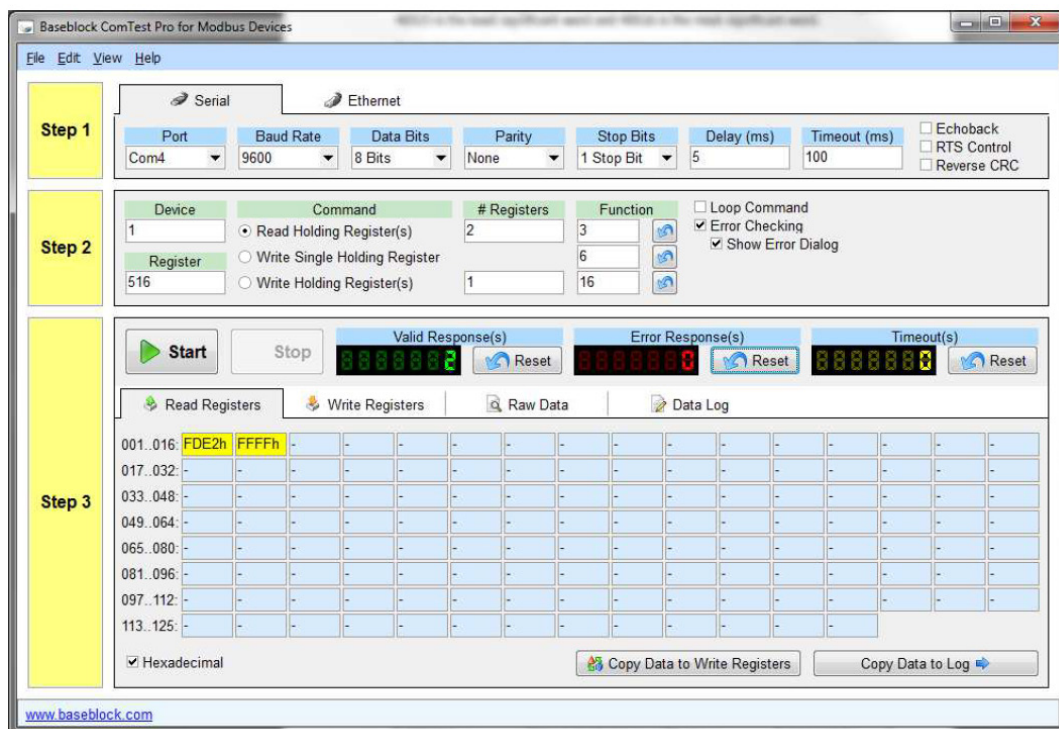

The highlighted value **0xFFFFFDE2** is a 32 bit signed integer .. so **-542**

There is a scaling multiplier of 0.1, so $-542 \times 0.1 = -54.2$ °C which is the value shown on the monitor.

Appendix C

Modbus RTU Comms

Appendix C Modbus RTU Comms

Accessing locked codes on Liquidew I.S. monitor (turning off "code blanking")



WARNING: It is recommended that "code blanking" is switched back ON after making any required changes to the configuration codes. Adjusting configuration codes without the express written instruction of Michell Instruments may result in damage to the monitor that is NOT covered under warranty.

Step 1

Press and hold the and buttons

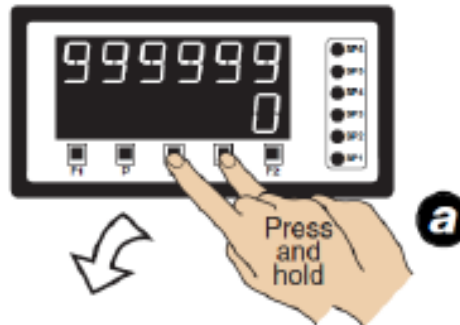

Step 2

While holding both buttons, press the Prog. button.

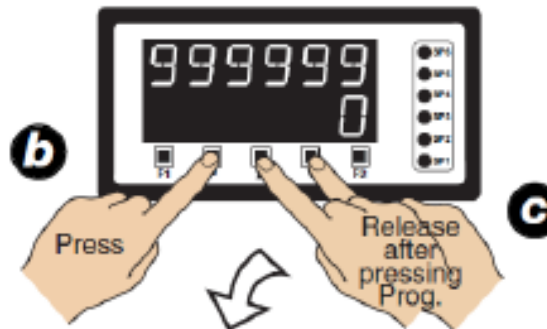

Prog = Select for Michell monitor

Step 3

Release the the and buttons and hold the Prog. button for approx. 1 sec then release

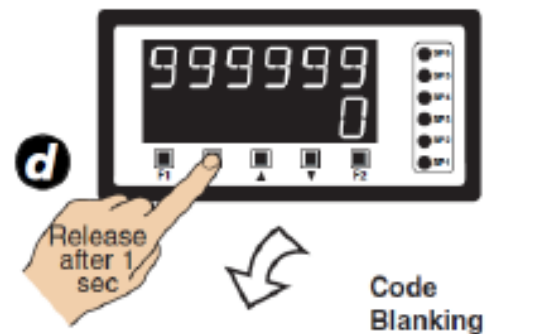

Example

NOTE: Unless otherwise requested, the factory default setting is OFF

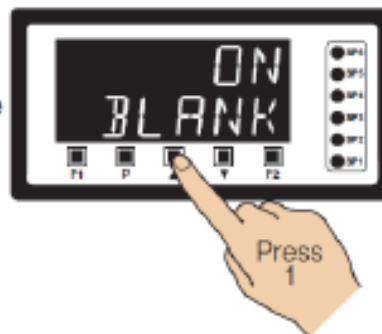

Step 4

Press the button to switch code blanking OFF
 Press to switch it back on, if later required!

continued from Step 4

Step 5

Press the Prog. button.

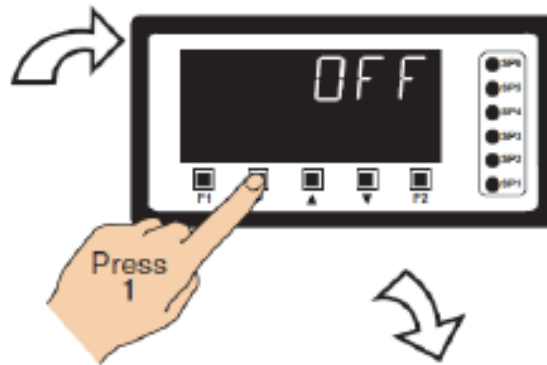

Step 6

Press the Prog. button.

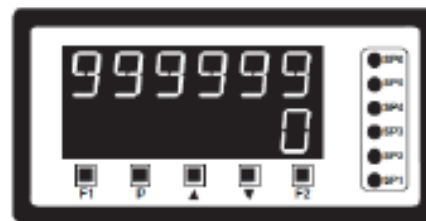
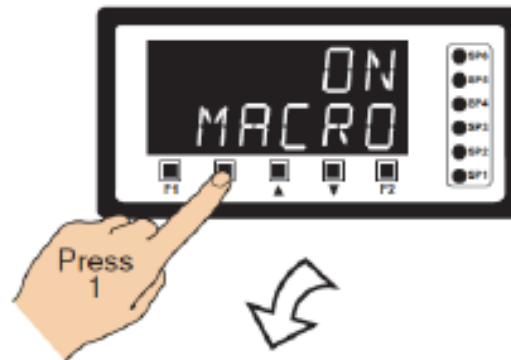

Operational Display

Appendix D

Hazardous Area Certification

Appendix D Hazardous Area Certification

The Liquidew I.S. Process Moisture Analyzer utilizes the Easidew PRO I.S. dew-point transmitter

The Easidew PRO I.S is certified compliant to the ATEX Directive (2014/34/EU), the IECEx scheme and SI 2016 No. 1107 UKCA product marking scheme for use within Zone 0, 1 and 2 Hazardous Areas and has been assessed as being so by CML Bv Netherlands (Notified Body 2776) and EUROFINS CML UK (Approved Body 2503).

The Easidew PRO I.S is certified compliant to the applicable North American Standards (USA and Canada) for use within Class I, Division 1 and Class I, ZONE 1 Hazardous Locations and has been assessed as being so by QPS.

D.1 Product Standards

This product conforms to the Standards:

BS/EN60079-0:2012/A11:2013	CSA C22.2 No. 60079-0:19
BS/EN60079-11:2012	CSA C22.2 No. 60079-11:14
FM Class 3600:2018	CSA 61010-1-12(R2017)
FM Class 3610:2010	UL61010-1
IEC60079-0:2011	UL60079-0
IEC60079-11:2011	UL60079-11

D.2 Product Certification

This product is attributed with the product certification codes:

**ATEX, UKCA & IECEx
II 1G Ex ia IIC T4 Ga (-20 °C...+70 °C)**

**North American
IS, Class I, Division 1, Groups A, B, C & D, T4
Class I, Zone 0, AEx ia IIC T4 Gb, Ex ia IIC T4 Gb
Tamb +70 °C**

D.3 Global Certificates/Approvals

ATEX	SGS Baseefa 06ATEX0330X
IECEx	IECExBAS 06.0090X
UKCA	BAS21UKEX0014X
QPS	LR1507-10

These certificates can be viewed or downloaded from our websites at:
www.processsensing.com & www.michell.com

D.4 Terminal Parameters

U_i	= 28 V
I_i	= 93 mA
P_i	= 820 mW
C_i	= 37 nF
L_i	= 0

D.5 Special Conditions

1. The wiring connections to the free socket must be made via crimped connectors in such a way that all the strands of the wire used are held securely by the crimp.
2. The plastic plug and socket create a potential for electrostatic discharge so must not be rubbed with a dry cloth or cleaned with solvents.
3. The Easidew PRO I.S Dew-Point Transmitter does not withstand the 500 V AC insulation test to frame. This must be taken into account when installing the equipment.

D.6 Maintenance and Installation

The Easidew PRO I.S. must only be installed by suitably qualified personnel and in accordance with the instructions provided and the terms of the applicable product certificates.

Maintenance and servicing of the product must only be carried out by suitably trained personnel or returned to an approved Michell Instruments Service Center.

Appendix E

System Drawings

Appendix E System Drawings

E.1 Baseefa Approved System Drawing

TABLE A

Type	Certificate Number	Interface	Connection to Easidew I.S.
Isolated Repeater	BAS98ATEX7343	KFD0-CS-Ex1.50P	Pin 1 (+) Pin 2 (-)
Dual Isolated Repeater	BAS98ATEX7343	KFD0-CS-Ex2.50P	Channel 1 - Pin 1 (+) Channel 1 - Pin 2 (-) Channel 2 - Pin 4 (+) Channel 2 - Pin 5 (-)
Transmitter Supply Isolator	BAS00ATEX7164	KFD2-CR-Ex1.20200	Pin 1 (+) Pin 3 (-)
Transmitter Supply Isolator	BAS00ATEX7164	KFD2-CR-Ex1.30200	Pin 1 (+) Pin 3 (-)
Smart Transmitter Power Supply	BAS98ATEX7060	KFD2-STC4-Ex1.H	Pin 1 (+) Pin 3 (-)
Repeater Power Supply	BAS01ATEX7155	MTL5041	Pin 2 (+) Pin 1 (-)
Dual Loop Isolator	BAS98ATEX2227	MTL5040	Pin 2 (+) Pin 1 (-) Pin 5 (+) Pin 4 (-)
Repeater Power Supply	BaseefaATEX0213	MTL5541	Pin 2 (+) Pin 1 (-)

THE CAPACITANCE AND EITHER THE INDUCTANCE OR THE INDUCTANCE TO RESISTANCE RATIO (L/R) OF THE CABLE MUST NOT EXCEED THE FOLLOWING VALUES:

GROUP	CAPACITANCE (µF)	INDUCTANCE (mH) OR	L/R RATIO (µH/ohm)
IIC	SEENOTE 1 * 40 nF	4.2mH	54 µH/Ω
IIB	613 nF	12.6mH	217 µH/Ω
IIA	2.11 µF	33mH	435 µH/Ω

THE ISOLATION OF THE SIGNAL WIRES WITH THE EASIDEW DISCONNECTED, MUST BE ABLE TO WITHSTAND A 500V AC INSULATION TEST.

AT INSTALLATION OF SYSTEM PERFORM A RISK ASSESSMENT IN ACCORDANCE WITH EN60079-25:2004 cl.10 AND INSTALL LIGHTENING PROTECTION AS NECESSARY.

THE SYSTEM MUST BE MARKED WITH A DURABLE LABEL. THE LABEL SHOULD APPEAR ON OR ADJACENT TO THE PRINCIPAL ITEM OF ELECTRICAL APPARATUS IN THE SYSTEM OR AT THE INTERFACE BETWEEN THE INTRINSICALLY SAFE AND NON-INTRINSICALLY SAFE CIRCUITS. THIS MARKING SHALL INCLUDE THE FOLLOWING INFORMATION:
Baseefa 07Y0027 AND THE WORD SYST OR SYSTEM.

NOTE 1. 46nF MAXIMUM CABLE CAPACITANCE IS ACCEPTABLE IN I/C INSTALLATIONS

FOR THE INTRINSIC SAFETY ISOLATORS SHOWN IN THE LIST BELOW.

FOR ISOLATORS NOT LISTED BELOW, BUT APPEARING IN TABLE A, ONLY 40nF

MAXIMUM CABLE CAPACITANCE IS ACCEPTABLE.

- KFD0-CS-Ex1.50P
- KFD0-CS-Ex2.50P
- KFD0-CR-Ex1.20200
- KFD0-CR-Ex1.30200
- MTL5041
- MTL5040
- MTL5541

GALVANIC ISOLATION INTERFACE

HAZARDOUS AREA ← SAFE AREA

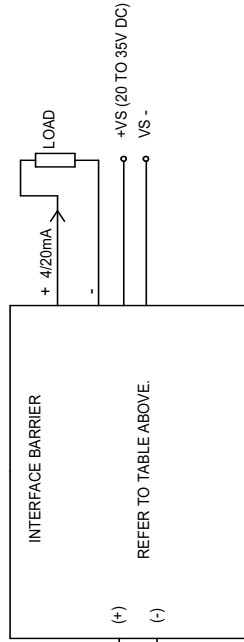

TRANSMITTER VERSION TERMINAL NUMBER	EASIDEW PRO.I.S.
3	2
1	4
⊕	⊕

SYSTEM LABEL

MICHELL INSTRUMENTS
EASIDEW I.S. DEWPOINT TRANSMITTER
SYSTEM CERTIFICATE No.s: Baseefa07Y0027
Exia IIC T4 (-20C TO +70C)

THIS DOCUMENT IS THE PROPERTY OF MICHELL INSTRUMENTS LTD. AND MUST NOT BE COPIED NOR DISCLOSED TO A THIRD PARTY WITHOUT THE CONSENT OF MICHELL INSTRUMENTS.



3/4 ANGLE PROJECTION	TOLERANCES: UNLESS OTHERWISE STATED DEC. PLACE ± 0.5 HOLE Ø: -0.0 1 DEC. PLACE ± 0.2	DRAWING UNITS	SCALE	ISSUE	MOD. No.	DATE	SIGN
	DIMENSIONS: 2 DEC. PLACE ± 0.1	mm	NTS	05	13395	16/12/13	IMA
MATERIAL	FINISH			04	11165	10/08/11	IMA
				03	PRO Variation	18/02/09	IMA
				02	08057	27/05/08	IMA
				01	CERT ISS	26/01/07	MSB
DRAWING NUMBER							SIGN
TITLE							
EASIDEW I.S. and EASIDEW PRO I.S. DEWPOINT TRANSMITTER SYSTEM							
DRAWING							
USED ON							
MICHELL INSTRUMENTS LTD. CAMBRIDGE ©							
SHEET 1 OF 1							A3

EX90352

E.2 QPS Approved System Drawing

THE CAPACITANCE AND EITHER THE INDUCTANCE OR THE INDUCTANCE TO RESISTANCE RATIO (L/R) OF THE CABLE MUST NOT EXCEED THE FOLLOWING VALUES:

GROUP	CAPACITANCE (µF)	INDUCTANCE (mH) OR	L/R RATIO (µH/ohm)
AB	46 nF	4.2mH	54 H/Ω
C	613 nF	12.6 mH	217 µH/Ω
D	2.1µF	33mH	435 µH/Ω

THE ISOLATION OF THE SIGNAL WIRES WITH THE EASIDEW DISCONNECTED, MUST BE ABLE TO WITHSTAND A 500V AC INSULATION TEST.

THE INSTALLATION MUST COMPLY WITH THE INSTALLATION PRACTICES OF THE COUNTRY OF USE, i.e. ANSI/ISA RP12.6 (INSTALLATION OF INTRINSICALLY SAFE SYSTEMS FOR HAZARDOUS [CLASSIFIED] LOCATIONS) AND THE NATIONAL ELECTRICAL CODE ANSI/NFPA 70.

THE CAPACITANCE AND THE INDUCTANCE OF THE HAZARDOUS AREA CABLES MUST NOT EXCEED THE VALUES GIVEN IN TABLE 1

HAZARDOUS LOCATION
CLASS I, DIVISION 1,
Gps A,B,C, & D
CLASS I, ZONE 0
AEx ia IIC T4 Ga
Ex ia IIC T4 Ga
Tamb+70°C

NON-HAZARDOUS LOCATION

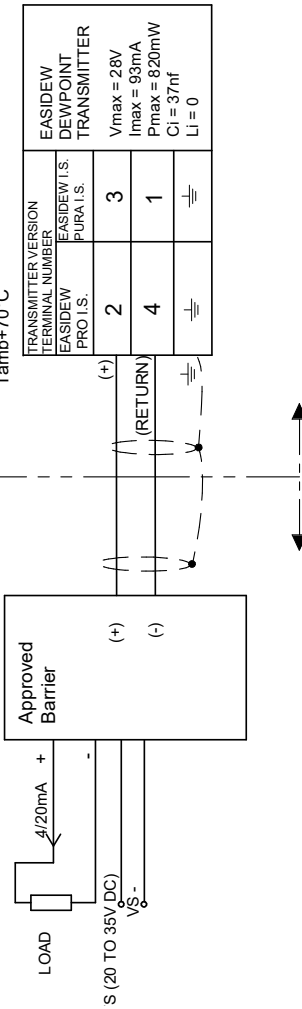

- Intrinsically safe(entity), Class 1, Div1, Group A,B,C,D
Hazardous Location Installations
- Control room equipment may not use or generate over 250Vrms.
 - Wire all circuits for power supply per CEC Part 1.
 - Use only entity approved safety barrier or other associated equipment that satisfy the following conditions:

$$V_{Co} \leq V_{max}, I_{sc} \leq I_{max}, C_{\geq} C + C_{CABLE}, L_{\geq} L + L_{CABLE}$$

Transmitter entity parameters are as follows:

- V max < 2.8Vdc
- I max < 93mA
- CI = 37nF
- LI = 0uH

- WARNING: SUBSTITUTION OF COMPONENTS MAY IMPARE INTRINSIC SAFETY.
- Ex ia is defined as Intrinsically Safe.

Type	Certificate Number	Interface	Connection to Easidew I.S.
Isolated Repeater	BAS98ATEX7349 UL Canada E106378CUL	KFD0-CS-Ex1.50P	Pin 1 (+) Pin 2 (-)
Dual Isolated Repeater	BAS98ATEX7343 UL Canada E106378CUL	KFD0-CS-Ex2.50P	Channel 1 - Pin 1 (+) Channel 1 - Pin 2 (-) Channel 2 - Pin 4 (+) Channel 2 - Pin 5 (-)
Transmitter Supply Isolator	BAS00ATEX7164 UL Canada E106378CUL	KFD2-CR-Ex1.20200	Pin 1 (+) Pin 3 (-)
Transmitter Supply Isolator	BAS00ATEX7164 UL Canada E106378CUL	KFD2-CR-Ex1.30200	Pin 1 (+) Pin 3 (-)
Smart Transmitter Power Supply	BAS99ATEX7080 UL Canada E106378CUL	KFD2-STC4-Ex1.H	Pin 1 (+) Pin 3 (-)

<p>3/4 ANGLE PROJECTION</p> <p>MATERIAL</p>	<p>TOLERANCES: UNLESS OTHERWISE STATED 0 DEC. PLACE: ± 0.5 HOLE Ø: 1 DEC. PLACE ± 0.2 ANGLES: ± 0.1°</p> <p>DIMENSIONS: FINISH</p>	<p>DRAWING UNITS: mm</p> <p>SCALE: NTS</p>	<p>09 QPS 30/06/21 IMA</p> <p>08 P Increased 02/11/17 IMA</p> <p>07 13395 16/12/13 IMA</p> <p>06 11081 06/04/11 IMA</p> <p>05 CERT ISS 15/06/09 IMA</p> <p>04 CERT ISS 25/03/09 IMA</p> <p>03 CERT ISS 16/06/08 IMA</p> <p>ISSUE IMCD. No. DATE SIGN</p>	<p style="text-align: center;">EASIDEW I.S. & EASIDEW PRO I.S. DEWPOINT TRANSMITTER SYSTEM DRAWIN. QPS</p> <p>USED ON MICHELL INSTRUMENTS LTD. CAMBRIDGE ©</p> <p style="text-align: right; font-size: 1.2em; font-weight: bold;">Ex90385QPS</p> <p style="text-align: right;">DRAWING NUMBER</p>
<p>THIS DOCUMENT IS THE PROPERTY OF MICHELL INSTRUMENTS LTD. AND MUST NOT BE COPIED NOR DISCLOSED TO A THIRD PARTY WITHOUT THE CONSENT OF MICHELL INSTRUMENTS.</p>				<p>DRAWN MSB DATE 10/03/06</p> <p>CHECKED DATE</p> <p>APPROVED DATE</p>
<p>MICHELL INSTRUMENTS LTD. 01/11/05 DDF03</p>				<p>SHEET 1 OF 1 A3</p>

Appendix F

Quality, Recycling & Warranty Information

Appendix F Quality, Recycling & Warranty Information

Michell Instruments is dedicated to complying to all relevant legislation and directives. Full information can be found on our website at:

www.michell.com/compliance

This page contains information on the following directives:

- Anti-Facilitation of Tax Evasion Policy
- ATEX Directive
- Calibration Facilities
- Conflict Minerals
- FCC Statement
- Manufacturing Quality
- Modern Slavery Statement
- Pressure Equipment Directive
- REACH
- RoHS3
- WEEE2
- Recycling Policy
- Warranty and Returns

This information is also available in PDF format.

Appendix G

Return Document & Decontamination Declaration

Appendix G Return Document & Decontamination Declaration

Decontamination Certificate

IMPORTANT NOTE: Please complete this form prior to this instrument, or any components, leaving your site and being returned to us, or, where applicable, prior to any work being carried out by a Michell engineer at your site.

Instrument			Serial Number	
Warranty Repair?	YES	NO	Original PO #	
Company Name			Contact Name	
Address				
Telephone #			E-mail address	
Reason for Return /Description of Fault:				
Has this equipment been exposed (internally or externally) to any of the following? Please circle (YES/NO) as applicable and provide details below				
Biohazards			YES	NO
Biological agents			YES	NO
Hazardous chemicals			YES	NO
Radioactive substances			YES	NO
Other hazards			YES	NO
Please provide details of any hazardous materials used with this equipment as indicated above (use continuation sheet if necessary)				
Your method of cleaning/decontamination				
Has the equipment been cleaned and decontaminated?			YES	NOT NECESSARY
Michell Instruments will not accept instruments that have been exposed to toxins, radio-activity or bio-hazardous materials. For most applications involving solvents, acidic, basic, flammable or toxic gases a simple purge with dry gas (dew point <-30°C) over 24 hours should be sufficient to decontaminate the unit prior to return. Work will not be carried out on any unit that does not have a completed decontamination declaration.				
Decontamination Declaration				
I declare that the information above is true and complete to the best of my knowledge, and it is safe for Michell personnel to service or repair the returned instrument.				
Name (Print)			Position	
Signature			Date	





Instrument Expert
Original factory
packaging
www.keruiyiqi.cn

www.ProcessSensing.com



<http://www.michell.com>