



Calibration	Configuration	Alerts	Helium
Calibration H2O			
1 ReZero	3 Set Zero	H2 0.0	0 - 10 PPM
2 ReSpan	4 Set Span	123027	counts
0 Previous Page		O2 0.0	0 - 10 PPM
		123326	counts
Zero: 0.00 PPM		H2O 0.0	0 - 100 PPM
Span: 2959497 counts		2405757	counts
Span: 25.50 PPM		CnHm OS	0 - 100 PPM
Span: 3313607 counts		8386862	counts
		9 Next	

LD8000
MULTIGAS

LD8000

MULTIGAS

USER'S MANUAL

TRACE IMPURITY ANALYZER



LD8000 MultiGas

Trace impurity analyzer

USER'S MANUAL
V1.10



Printed in Canada
Copyright 2017

TABLE OF CONTENTS

1. Forewarning	2
2. Warranty and Service Policies	3
3. Cautions & Warnings.....	6
3.1 Electrical shock hazard	6
3.2 Possible explosion hazard	6
4. Declaration of conformity	7
5. Specifications	9
6. Cautions & Installation	10
6.1 Detector cautions	10
6.2 Analyzer application	10
6.3 Installation	11
7. Hardware Description & Maintenance	14
7.1 Detector module.....	14
7.2 Motherboard and MCU.....	15
7.3 Solenoid Proportional Valve.....	16
7.4 LCD Touch screen Display.....	16
8. Operation	17
8.1 Real-Time menu	17
8.2 Calibration menu.....	19
8.3 Configuration menu	20
8.3 Alerts menu.....	22
8.4 Range menu	24
8.5 Administration menu	25
9. Drawings & Schematics.....	29
9.1 Parts Identification (4U)	29
9.2 Parts Identification (3U)	30
9.3 Back Panel Identification (3U)	31
9.4 Back Panel Identification (4U)	32
9.5 Back Panel Connector Identification (3U and 4U).....	33
9.6 Piping Schematic (N2-O2-H2O-CnHm / 4U) with PED.....	34
9.7 Piping Schematic (O2-N2 / 3U) with O2 electrochemical	35
9.8 Electrical Schematic (N2-O2-H2O-CnHm / 4U) with PED.....	36
9.9 Electrical Schematic (N2-O2-H2O-CnHm / 4U) with O2 electrochemical	37
9.10 Electrical Schematic (O2-N2 / 3U) with O2 electrochemical	38
9.11 Enclosure Dimensions & Panel Cutout (4U).....	39
9.12 Enclosure Dimensions & Panel Cutout (3U).....	40
9.13 Back Panel Dimensions (4U).....	41
9.14 Back Panel Dimensions (3U).....	42
10. Procedures.....	43
10.1 Analog Output Calibration Procedure (4-20mA)	43
10.2 Software Update Procedure	47
10.3 Oxygen Electrochemical cell installation at reception.....	49
11. Options.....	53

11.1 RS232/RS485/Profibus communication	53
11.2 Integrated stream selector & auto calibration	56
11.3 Zero gas free system	59
11.4 Low pressure pump.....	62
11.5 O2 and N2 dual measurement (3U cabinet).....	64
12. Ordering Information and spare parts	66
13. Maintenance	67
13.1 Spare part list	67
13.2 Frequently asked questions	67

1. Forewarning

This manual is required to be read by any user wanted to use the LD8000 Multigas Trace Impurity analyzer. It contains important information to successfully operate the instrument. LDetek assumes that all operators have taken the time to read this information before install, operate and troubleshoot the analyzer.

If any error is suspected by the reader, please contact LDetek. LDetek reserves the right to make changes to subsequent editions of this document without prior notice to holders of this edition.

In no event shall LDetek be liable for any damages arising out of or related to this document or the information contained in it.

We would like to thank you for choosing LDetek as your gas analyzer supplier.

2.Warranty and Service Policies

Goods and part(s) (excluding consumable) manufactured by the seller are warranted to be free from defects in workmanship and material under normal use and service for **twelve (12)** months after installation and start-up and not exceeding **eighteen (18)** months from shipment date. Consumable, chemical trap, O-rings, etc., are warranted to be free from defects in workmanship and material under normal use and service for ninety (90) days from the date of shipment by the seller. Goods, part(s) proven by the seller to be defective in workmanship and/or material shall be replaced or repaired, free of charge, F.O.B. Seller's factory provided that the goods, part(s) are returned to Seller's designated factory, transportation charges prepaid, within the twelve (12) months after installation and start-up and not exceeding 18 months from shipment date. In the case of consumable, within the ninety (90) days period of warranty, a defect in goods, part(s) and consumable of the commercial unit shall not operate to condemn such commercial unit when such goods, part(s) and consumable are capable of being renewed, repaired or replaced.

The Seller shall not be liable to the Buyer, or any other person, for the loss or damage directly or indirectly, arising from the use of the equipment of goods, from breach of any warranty, or any other cause.

ALL OTHER WARRANTIES, EXPRESSED OR IMPLIED ARE HEREBY EXCLUDED.

IN CONSIDERATION OF THE HEREIN STATED PURCHASE PRICE OF THE GOODS, SELLER GRANTS ONLY THE ABOVE STATED EXPRESS WARRANTY. NO OTHER WARRANTIES ARE GRANTED INCLUDING, BUT NOT LIMITED TO, EXPRESS AND IMPLIED WARRANTIES OF MERCHANTABILITY AND FITNESS FOR A PARTICULAR PURPOSE.

THIS WARRANTY IS THE ONLY WARRANTY MADE BY LDETEK INC. WITH RESPECT TO THE GOODS DELIVERED HEREUNDER, AND NO EMPLOYEE, REPRESENTATIVE OR OTHER PERSON OR ENTITY IS AUTHORIZED TO ASSUME FOR LDETEK INC ANY OBLIGATION OR LIABILITY BEYOND OR AT VARIANCE WITH THIS WARRANTY IN CONNECTION WITH THE SALE OF LDETEK PRODUCTS.

Limitations of Remedy. SELLER SHALL NOT BE LIABLE FOR DAMAGES CAUSED BY DELAY IN PERFORMANCE. THE SOLE AND EXCLUSIVE REMEDY FOR BREACH OF WARRANTY SHALL BE LIMITED TO REPAIR OR REPLACEMENT UNDER THE STANDARD WARRANTY CLAUSE. IN NO CASE, REGARDLESS OF THE FORM OF THE CAUSE OF ACTION, SHALL SELLER'S LIABILITY EXCEEDS THE PRICE TO BUYER OF THE SPECIFIC GOODS MANUFACTURED BY SELLER GIVING RISE TO THE CAUSE OF ACTION. BUYER AGREES THAT IN NO EVENT SHALL SELLER'S LIABILITY EXTEND TO INCLUDE INCIDENTAL OR CONSEQUENTIAL DAMAGES. CONSEQUENTIAL DAMAGES SHALL INCLUDE BUT ARE NOT LIMITED TO, LOSS OF ANTICIPATED PROFITS, LOSS OF USE, LOSS OF REVENUE, COST OF CAPITAL AND DAMAGE OR LOSS OF OTHER PROPERTY OR EQUIPMENT. IN NO EVENT SHALL SELLER BE

LIABLE FOR PROPERTY DAMAGE AND/OR THIRD-PARTY CLAIMS COVERED BY UMBRELLA INSURANCE AND/OR INDEMNITY COVERAGE PROVIDED TO BUYER, ITS ASSIGNS, AND EACH SUCCESSOR INTEREST TO THE GOODS PROVIDED HERE UNDER.

Major force. The seller is not liable for failure to perform due to labour strikes or acts beyond the seller's direct control.

SERVICE POLICY

1. If a product should fail during the warranty period, it will be repaired free of charge. For out-of-warranty repairs, the customer will be invoiced for repair charges at current standard labour and materials rates.
2. Customers who return products for repairs, within the warranty period, and the product is found to be free of defect, may be liable for the minimum current repair charge.
3. For parts replacement, the original part must be returned with the serial and model numbers of the analyzer. **NO PART WILL BE SHIPPED IF THE ORIGINAL IS NOT SENT BACK TO LDETEK INC.**

RETURNING A PRODUCT FOR REPAIR

Upon determining that repair services are required, the customer must:

1. Obtain an RMA (Return Material Authorization) number.
2. Supply a purchase order number or other acceptable information.
3. Include a list of problems encountered along with the name, address telephone, and RMA number.
4. **Ship the analyzer in its original crating or equivalent. Failure to properly package the analyzer will automatically void the warranty.**
5. **Every gas connection must be capped with appropriate metal caps. Failure to do so will automatically void the warranty.**
6. Write the RMA number on the outside of the box.
7. Use an LDetek approved carrier. Also, the delivery must be sent to LDetek facilities. LDetek will not accept airport to airport delivery.
8. LDetek will not cover the transportation fees.

Other conditions and limitations may apply to international shipments.

PROPRIETARY RIGHTS

Buyer agrees that any LDetek's software, firmware and hardware products ordered or included in the goods ordered are proprietary of LDetek. No change, modification, defacement, alteration, reverse engineering, neither software decompilations nor reproduction of such software or hardware products, or disclosures of programming content to other parties is authorized without the express written consent of LDetek.

To maintain LDetek's trade secret and other proprietary protection of such software and firmware, such items are not sold hereunder but are licensed to the buyer.

LDetek Inc. reserves the right to interrupt all business relationships and warranty or services if there is any tentative from any customers to reverse engineering any of LDetek products or to tamper with any sealed module.

Trademarks and product identification as LD8000 Multigas are the property of LDetek Inc. and shall be used only in connection with LDetek's products. No third party could remove or deface any model number or marks.

3. Cautions & Warnings

Improper installation, operation or service of this analyzer may cause damage to the analyzer and void the manufacturer's warranty.

3.1 Electrical shock hazard

Do not operate unless the cabinet is securely closed. Servicing this instrument implies possible exposure to shock hazard level voltages which can cause death or serious injury.

For both safety and proper performance, this instrument **must** be connected to a properly grounded three-wire source of electrical power.

Both alarm switching relay contacts and digital output contacts wired to a separate power source must be disconnected before servicing.

Tampering or unauthorized substitution of components may adversely affect the safety of this product. Use only factory-approved components for repair.

3.2 Possible explosion hazard

Never introduce other gases than the sample detailed on the specification sheet of the instrument. If explosive, flammable or corrosive gases or mixtures are allowed to flow in the analyzer, fire or explosion may result. This analyzer is not designed to be used in hazardous areas.

This analyzer must be installed in laboratory environments: moisture- and vibration-free, with stable temperatures.

4.Declaration of conformity

EU Declaration of Conformity



1. Product model: LD8000 online analyzer series
2. Name and address of the manufacturer:

LDetek Inc.
990 Monfette E.
Thetford Mines, QC G6G 7K6
+1 (418) 755-1319
Email: info@ldetek.com

This product is in conformity with the following EU Directives ,Standard(s) or Normative Document(s):

3. Directives.

Low Voltage Directive (LVD) 2014/35/EU,

Electromagnetic Compatibility Directive (EMC) 2014/30/EU,

Restriction of Hazardous Substances (RoHS) Directive 2011/65/EU/2014/68/EU

Pressure Equipment Directive

This product does not bear CE marking for the Pressure Equipment Directive, but are supplied in accordance with Article 4, paragraph 3 of 2014/68/EU by using SEP (sound engineering practice) in the design and manufacturer and are provided with adequate instructions for use.

4. Standards:

EN61326-1:2013 Electrical equipment for measurement, control and laboratory use – EMC requirements –Class B (emissions) and Industrial Locations (immunity).

EN61010-1:2010 Safety Requirements for Electrical Equipment for Measurement, Control, and Laboratory Use - Part 1: General Requirements

5. On behalf of the above-named company, I declare that under our sole responsibility, on the date that the equipment accompanied by this declaration is placed on the market, it conforms with all technical and regulatory requirements of the above listed EU Directives.

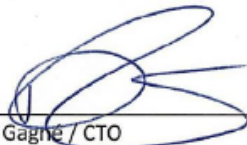

Dany Gagné / CTO
Thetford Mines, QC
Date: 06/21

990, rue Monfette Est, Thetford Mines G6G 7K6
Tél. 418 755-1319, Tél. 418 755 1329

UK Declaration of Conformity



1. Product model: LD8000 online analyzer series

2. Name and address of the manufacturer:

LDetek Inc.
990 Monfette E.
Thetford Mines, QC G6G 7K6
+1 (418) 755-1319
Email: info@ldetek.com

This product is in conformity with the following UK Directives ,Standard(s) or Normative Document(s):

3. Directives.

Electrical Equipment (Safety) Regulations 2016 : S.I. 2016:1101

Electromagnetic Compatibility Regulations 2016: S.I. 2016:1091

The Restriction of the Use of Certain Hazardous Substances in Electrical and Electronic Equipment Regulations 2012 : S.I. 2012:3032

Pressure Equipment (Safety) Regulations 2016: S.I. 2016:1105

4. On behalf of the above-named company, I declare that under our sole responsibility, on the date that the equipment accompanied by this declaration is placed on the market, it conforms with all technical and regulatory requirements of the above listed UK Directives.

A handwritten signature in blue ink, appearing to read "Dany Gagné".

Dany Gagné / CTO
Thetford Mines, QC
Date: 08/21

990, rue Monfette Est, Thetford Mines G6G 7K6
Tél. 418 755-1319, Tél. 418 755-1329

5. Specifications

Sensor	PlasmaDetek	PlasmaDetek	PlasmaDetek	PlasmaDetek	SenzTx	SenzTx	Easidew	QMA
Measurement technology	PED	PED	PED	PED	Zirconia (ZR)	Electrochemical (EC)	Ceramic sensor	Quartz crystal
Manufacturer	LDetek	LDetek	LDetek	LDetek	NTRON	NTRON	Michell Instruments	Michell Instruments
Impurity	N2	O2	H2O	CnHm	O2	O2	H2O	H2O
Sample gas	Ar-He	Ar-He	Ar-He	Ar-He	Multiple gases	Multiple gases	Multiple gases	Multiple gases
Ranges (default)	0-1ppm (resolution 10ppb)	0-3ppm (resolution 10ppb)	0-3ppm (resolution 10ppb)	0-3ppm (resolution 10ppb)	0-10ppm (resolution 0.5ppm)	0-10ppm (resolution 0.1ppm)	0-10ppm (resolution 0.5ppm)	0-10ppm (resolution 100ppb)
	0-10ppm (resolution 100ppb)	0-30ppm (resolution 100ppb)	0-30ppm (resolution 100ppb)	0-30ppm (resolution 100ppb)	0-100ppm (resolution 1ppm)	0-100ppm (resolution 1ppm)	0-100ppm (resolution 1ppm)	0-100ppm (resolution 1ppm)
	0-100ppm (resolution 1ppm)	0-50ppm (resolution 1ppm)	0-100ppm (resolution 1ppm)		0-1000ppm (resolution 1ppm)	0-1000ppm (resolution 1ppm)	0-1000ppm (resolution 1ppm)	0-1000ppm (resolution 1ppm)
	up to 5000ppm available	up to 50ppm available	up to 100ppm available	up to 30ppm available	up to 96% available	up to 25% available	up to 3000ppm available	up to 2000ppm available
Limit of detection (LDL)	10ppb	50ppb	50ppb	50ppb	0.5ppm	0.1ppm	0.5ppm	20ppb
Accuracy	<+/- 1% of scale	<+/- 1% of scale	<+/- 1% of scale	<+/- 1% of scale	<+/- 1% of scale	<+/- 1% of scale	<+/- 1% of scale	<+/- 1% of scale
Response time (T90)	<10 sec	<10 sec	<10 sec	<10 sec	<10 sec	<10 sec	<5 min	<5 min
Sensor life expectation	10 years	10 years	10 years	10 years	3-5 years	1 year	3-5 years	3-5 years
Operating temperature	5-45 Celsius							
Sample gas temperature	0-100 Celsius							
Sample flow requirement	25-200ml/min	25-200ml/min	25-200ml/min	25-200ml/min	100-200ml/min	100-200ml/min	1-5 L/min	300-500ml/min
Operating sample pressure	3-30psig (for lower sample pressure requirement, an additional high purity pump is used)							
Outlet pressure	Atmospheric							
Inlet fittings	1/8" or 1/4" Swagelok compression or VCR							
Outlet fittings	1/8" or 1/4" Swagelok compression or VCR							
Doping gas	N/A	Nitrogen grade 5.0	Nitrogen grade 5.0	Nitrogen grade 5.0	N/A	N/A	N/A	Nitrogen grade 5.0
Calibration gas	Zero: LDP1000 purified gas (Getter) (span gas if zero gas-free option included) Span: 50 to 90% of the working range							
Standard features	Manual or auto-ranging, MCU embedded system, touchscreen 5.6" LCD, 4-20mA outputs, alarm historic, digital outputs for status, 3 ranges, calibration in progress							
Options	Internal sampling system for zero/span/sample, serial communication RS232-RS485-Modbus-Profibus, 2 level alarms, zero gas-free calibration system							
Supply	110VAC 50-60Hz / 220VAC 50-60Hz							
Power consumption	100-250 watts depending on the combination of sensors and options mounted in the unit							
Enclosure type	3U or 4U rackmount type depending on the combination of sensors and options mounted in the unit							
Ingress protection	IP20 in accordance with IEC 60529							
Enclosure finish	RAL7030 powder coat							
Weight	25-40 lbs (11-18kg) depending on the combination of sensors and options mounted in the unit							
Certification	In compliance with EMC directive 2004/108/EC, EN 61000-6-2:2005 for immunity & EN 61000-6-4:2007 for emissions.							

6.Cautions & Installation

6.1 Detector cautions

The LD8000 Multigas uses a detection technique known in the industry for many years. The principle is not new, but the design of the detector and the electronics make it unique for its performance and reliability.

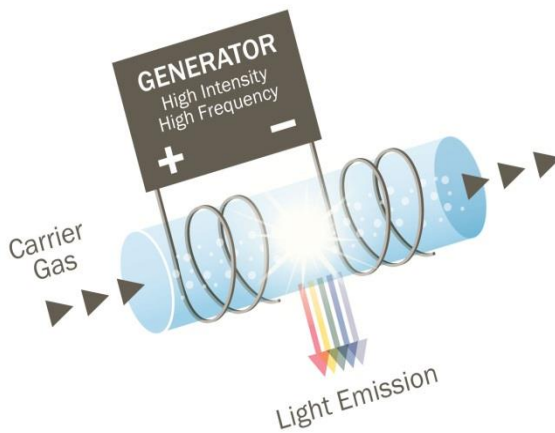

The analysis is based on spectroscopic emission. The detector is a pure quartz cell put in an electromagnetic field created by a specific high-intensity generator. This electromagnetic field creates plasma that emits light to different wavelengths. A filter for nitrogen is used to avoid any interference and get the best performance.

The detector also uses a “Duty Cycle Controlled System” to increase the lifetime of the cell. It increases lifetime, stability and sensitivity compared to any other system on the market.



Since the cell is made of thin quartz, this analyzer must be used at **atmospheric pressure to avoid any cell cracking.**

Any backpressure to the detector vent connection will cause damage and replacement of the plasma detector module.

6.2 Analyzer application

The LD8000 Multigas is designed to be used **for the impurity and sample detailed on the specification sheet of the instrument only**. Using this instrument with any other type of gases can cause damage to the analyzer.

This is not an instrument to be used in hazardous areas.

6.3 Installation

Some simple steps are required to make a successful installation.

Unpack the instrument from the box carefully without damaging the gas connections. Inspect the instrument to be sure it is in good condition and hasn't been damaged during shipping.



Remove all plugs from the gas connections on the rear panel. **Don't forget to remove the plugs on all sample vents connections and make sure to never pressurize the instrument.** It will damage the plasma detectors. This instrument is made to work at atmospheric pressure.

Any backpressure to the sample vents connection will cause damage and replacement of the plasma detector modules.

Make sure to purge the gas line with pure gas (using UHP grade 5.0 or better) before connecting gas to the sample inlet connection.

Connect the sample gas to the sample inlet of the instrument.

WARNING: BEFORE CONNECTING A SAMPLE INLET GAS, BE SURE THE SAMPLE VENT CONNECTIONS ARE AT ATMOSPHERIC PRESSURE.

If specified, LDT-H2O-50 and LDT-O2-50-VCR-1/8 (respectively moisture and oxygen traps) must be mounted at the appropriate location on the back panel of the instrument. These traps have 1/8" VCR ends at both extremities and it is very important to install new VCR seals during the installation. The traps must not be exposed to ambient air, otherwise, they will be contaminated and their lifespan will be reduced considerably. Refer to the piping drawing in section 9.6 for a better understanding of trap installation. These traps are consumables and must be replaced every year for normal use.

Adjust the Sample bypass purge valve mounted on the front panel of the instrument to have a minimum of 100scm flow rate. This is to ensure proper purging of the sample gas. Be sure to always keep the flow rate of this sample bypass valve at a minimum of 100scm for good operation of the system.

Open, the On/Off green bellow valve mounted on the back panel of the instrument. If needed, refer to the piping drawing in section 9.6. This valve is used to manually shut off the gas source in case of severe sample contamination with heavy contaminants as liquid or dust.



Be sure to connect the right source voltage to the instrument. Please refer to the model number of the instrument that shows the voltage of it (110VAC or 240VAC). The red indicator in the power inlet module on the back panel must have the same voltage indication as the indication shows in the model number. Having the wrong power source connected to the instrument can cause severe damage to the instrument.

Turn on the unit.

The sample flow setpoints of the 3 proportional sample valves must stabilize at 100sccm or at indicated values on the operating parameters sheet. Each proportional valve is used to control the flow rate individually to each plasma detector. It is very important that the sample flow rate of each sample stays stable to ensure proper purging of the unit.

The plasma detectors should turn on by itself after few minutes and start showing ppm reading. Allow at least 24 hours of purging before using the instrument. Prior to run a calibration of the instrument, it is very important to refer to the first section of the real time menu (refer to real time menu at section 7.1 of this manual) to validate that the cell counts of each of the 4 detectors have reached the same values as factory values. To compare the values, please refer to LDetek LD8000 MultiGas operating data sheet. The cell counts values for each detector must be within +/-10% of the ones that appear on the operating parameters sheet.

A calibration must be done after confirming the cell count values for all detectors are correct. Always refer to the certified calibration sheet included with the instrument to compare the zero and span counts with the calibration counts obtained by LDetek prior to shipping.

Special notices:

Plasma Shut off protection system: When the CnHm impurity level goes over 5ppm (this parameter can be modified on request) in the plasma used for CnHm detection, a security system automatically turns off the two other plasma detectors used for respectively N₂(Plasma1), H₂O(Plasma2) and O₂ (Plasma 3). This security system is to avoid plasma contamination with carbon deposit. It is well known that carbon tends to stick on the walls of any surfaces. Especially in a quartz chamber used for emission detection of species. The LD8000 MultiGas has been designed to avoid such type of detector contamination by having this protection shut off system. The plasma detectors automatically turn back on when the CnHm measurement goes back to a value below 5ppm.

Trap(s) protection system: When the H₂O or O₂ level(s) go(es) over 20 ppm (this parameter can be modified on request) in the plasma used for H₂O or O₂ detection, a security system automatically turns the protection valve that supply the CnHm plasma (plasma#4) off. This security system is to avoid trap contamination with moisture or Oxygen. The LD8000 MultiGas has been designed to avoid such type of trap contamination by having this trap protection shut off system. The protection valve will automatically turn back on when the H₂O or O₂ measurement goes back to a value below 20 ppm.

CnHm detection : The Plasma 4 used for CnHm detection could be combined with a trap converter system that is another protection technique to avoid the plasma used for CnHm detection to be contaminated with carbon as well. Using the combination of the plasma shut off protection system and the converter system, we ensure that the LD8000 MultiGas detectors are never damaged by hydrocarbons coating during normal operation.

Calibration : Because of the protection system, it is very important to calibrate the CnHm individually using a separate span calibration bottle or a mixed cylinder that contains lower concentration than the 5 ppm protection threshold. The three other impurities can be calibrated using

the same span calibration bottle (with a gas that contains less than 20 ppm of O₂ and H₂O to avoid Trap protection system to interfere with CnHm measurement).

7. Hardware Description & Maintenance

The LD8000 MultiGas has major components included in the chassis. This section will describe each component that can be replaced for maintenance or upgrade.

7.1 Detector module



The detector module is a 142 mm (5.6”) x 107 mm (4.2”) x 77 mm (3”) box that contains all components needed to detect the impurity and provide the signal to the electronics. The multi pin connectors are used to interface the motherboard with the module. No other electrical connection is required.

Two Compression 1/16” Stainless Steel tubes are used for connecting gas inlet and gas outlet to the Detector Module.



This module can be defective if the detector has been pressurized or contaminated with inappropriate liquid or gases. In some cases it can be cleaned with a proper solvent to clean the surface of the cell inside the module. However this alternative can be done only at the first stage of contamination. If any suspected contamination is detected, please advise the factory if the cleaning solution process is possible. If the instrument looks unstable, please get in contact with LDetek factory, they will guide you through different testing steps to evaluate the status of the Detector. In the eventuality that the Detector needs to be replaced, there are only the 2 cables and the two fittings must be disconnected. After having installed the new detector module, just reboot the instrument, purge the unit for a minimum of 12 hours and proceed to a recalibration of the unit.

The defective unit must be returned to LDetek Factory for evaluation of it.

Please refer to the ordering section of this manual to get the part number for a replacement part.

Note: Always provide S/N of the instrument where the part will be installed when ordering replacement part. This is to ensure to have the appropriate version for your instrument.

7.2 Motherboard and MCU

This electronic board controls all components inside the analyzer: Flow reading, Flow control, Detectors acquisition, Detectors control, LCD Display, Temperature reading, Alarms, 4-20mA Analog Output and all other options available. This board must be replaced only if you had the confirmation from LDetek.



When replacing this motherboard be sure to avoid any electrostatic contact. This Motherboard is built in a way that most parts can be easily replaced by just snapping a new part on it. This avoids the whole replacement of the circuit if only one component is damaged. It is a cost effective solution for satisfying our clients.



Here are the sub modules on this board that can be replaced just by unsnapping the damaged part and replacing it by a new part:

- 4-20mA Analog Output
- Flow sensor
- Temperature sensor
- 4-20mA fuse
- Relay fuse
- Microcontroller Unit

For localization of the components on the Motherboard, please refer to the Parts Identification drawing at section 8.1 in this manual. It appears in the Drawing section.

Please refer to the Ordering section of this manual to get the part number for a replacement part.

Note: Always provide S/N of the instrument where the part will be installed when ordering replacement part. This is to ensure to have the appropriate version for your instrument.

7.3 Solenoid Proportional Valve

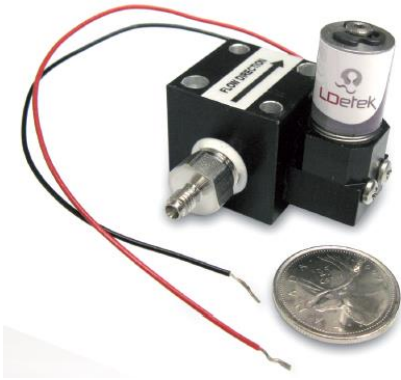

This valve is used to control the flow inside the detector module. One valve is used individually to control the flow rate in each plasma detector. A total of three valves are used for three plasma detectors. This is a very low dead volume valve that allows minimal purging at startup and very quick for flow stabilization. This micro valve has been designed by LDetek to meet good performances of the instrument.

The standard configuration of the LD8000 MultiGas allows a pressure range going from 3 PSIG up to 30 PSIG. Having higher pressure may cause damage to the valve. In the eventuality that valve has been exposed to high pressure, the valve may start to have difficulties to stay stable or also have difficulties to close totally. In this case, the valve would have to be re-build. So, a replacement valve can be easily installed. There are only two wires and two fittings to connect to do the replacement.

Please refer to the Ordering section of this manual to get the part number for a replacement part.

Note : Always provide S/N of the instrument where the part will be installed when ordering replacement part. This is to ensure to have the appropriate version for your instrument.

7.4 LCD Touch screen Display



This 5.6'' low power consumption LED Intelligent LCD Touch Screen Display Module allows having a user's friendly interface. Moreover, its touch screen allows easy navigation through the different menus. Carefully handling the touch screen is essential to ensure not damaging it.

If the LCD is damaged, it can be easily replaced by removing the four fixing screws and the two connectors on it. A new LCD can be ordered from LDetek. The LCD comes already configured for the instrument.

Please refer to the Ordering section of this manual to get the part number for a replacement part.

Note: Always provide S/N of the instrument where the part will be installed when ordering replacement part. This is to ensure to have the appropriate version for your instrument.

8.Operation

The LD8000 MultiGas has a microcontroller interface with 5.6 LED touch screen. A keypad is also available to enter specific values used in the software. The touch screen must be handled carefully to avoid any problem with the sensitivity. The following figures show the different menus to operate the instrument.

8.1 Real-Time menu

On the right of the screen, the real time menu section is always shown and completely independent of the left side menu selection.

The first page of the Real Time menu displays the values read by the different detectors of the analyser. A number of 1 to 4 impurities can be shown there. Names of impurities measured, actual Ranges selected, Unit of measurement (PPM / PPB/ %) and the digital signal from the detectors in counts (24 bits). *The range of each impurity can be changed by using the Select button on the keypad, if the analyzer is not in Lock Range mode*

Calibration	Configuration	Alerts	Helium
Calibration Choice			
1 Calib N2	5 Sample Stream		N2 0 - 200
3 Calib H2O	6 Span1 Stream		6 233178 PPM counts
4 Calib CnHm	7 Span2 Stream		H2O 0 - 10
			9.7 4395602 PPM counts
			CnHm 0 - 30
			1.0 1678498 PPM counts
			9 Next

Press Next button to go to the second page of the Real Time menu.

The second page displays up to 5 flows reading in ml/min and the digital counts of each Flow sensor (Only for diagnostic usage) .

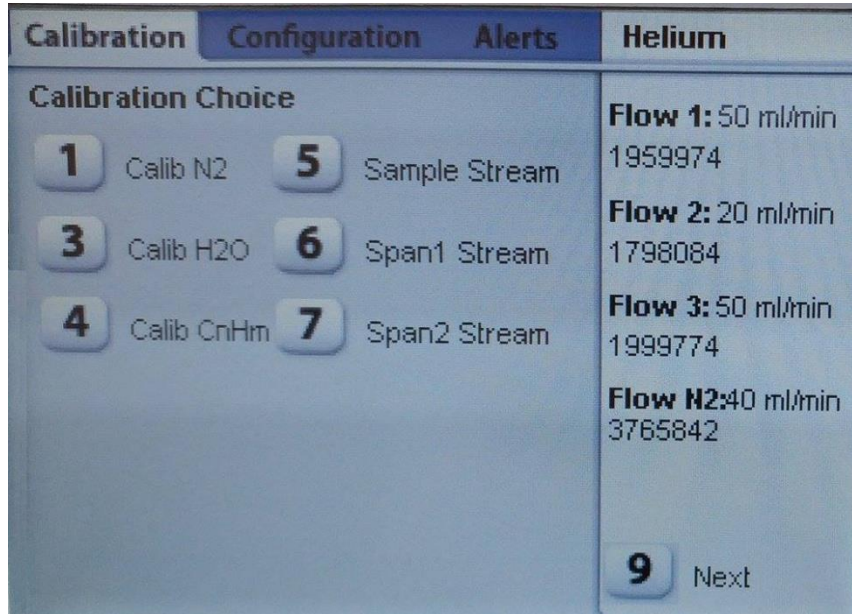

Press next again to go to the third section of the real time menu.

The third page displays up to 5 gas detectors reading in digital counts (Only for diagnostic usage) and the gas inlet stream currently selected. *The stream activated area is only shown if the analyser contains the ISS option*

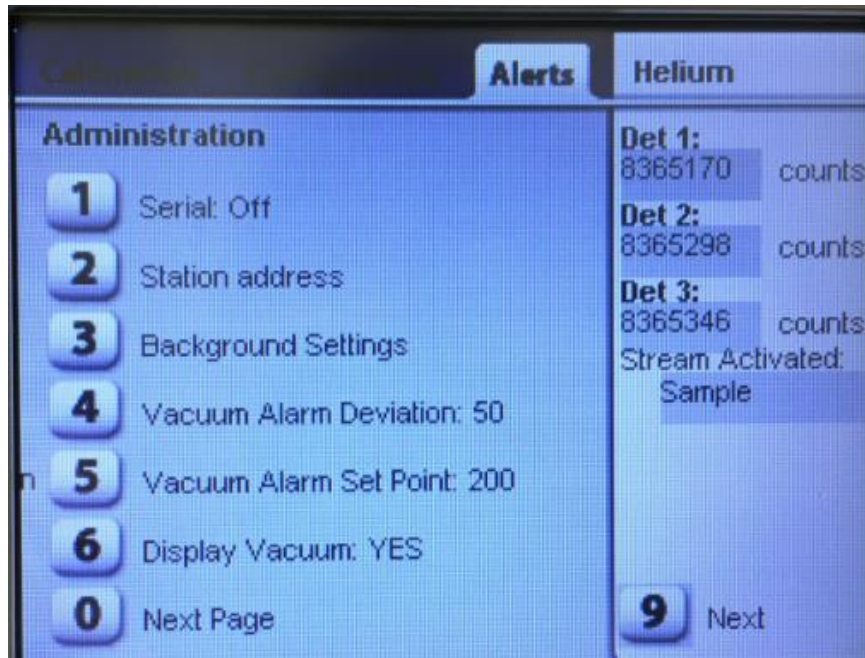

Press next again to go to the fourth section of the real time menu.

The fourth page displays the internal temperature of the analyser, the internal gas purifier temperature and the internal vacuum pump Absolute pressure. * The A.Pres. area is only shown if the analyser contains a internal vacuum pump*

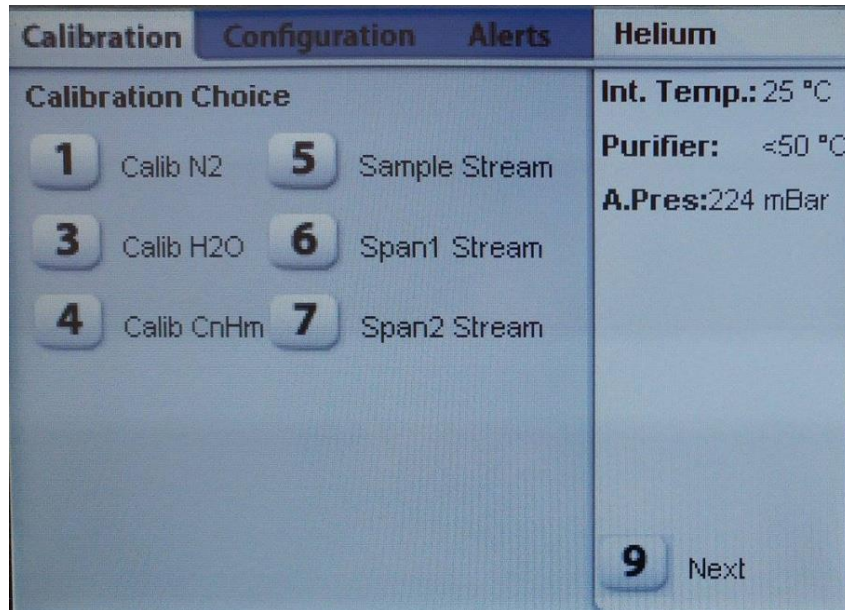

8.2 Calibration menu

This menu is used to calibrate a specific detector in relation to the specific range of the instrument and select the sample inlet to analyse. *Sample stream selection area is only shown and available if the analyser has the ISS option installed*

If you want to perform zero or span gas calibration of a detector you have to push 1-2-3 or 4 to do the gas selection to calibrate. There is possibility to calibrate up to 4 detectors.

If you want to select a stream to analyse, you have to push 5-6-7- 8 or 9. There is possibility to do a selection of up to 5 sample gas inlets.



Sample Flow Set Point: (0 to 200 cc/min): Used to enter the sample flow set points of different gas flow in the analyser. Some are automatic and others are adjusted with manual regulators. Possibility to have up to 5 flow setpoints in this menu.

Automatic Ranging: (on or off): Used to select the ranging mode the analyser will follow. When OFF the analyser will need someone to manually change the range from Range 1 to Range 2 (push select) or the opposite. When ON the range of the analyzer will switch automatically when reaching over scale (on Range 1) or a value that Range 1 can measure (on Range 2).

Alarm settings: Used to set the alarms threshold values that will activate the Alarms relays 1 and 2 of the analyzer. When the analysis reading is higher than the threshold of the alarm, the relay will be activated. There are two alarms level for each detector.

Calibration	Configuration	Alerts	Helium
Configuration			N2 0 - 10 0.0 PPM
1	4-20mA modules: Hold		1982452 counts
2	Sample Flow Set Point		O2 0 - 10 0.0 PPM
3	Automatic Ranging: Off		88530 counts
4	Alarms Settings		CnHm 0 - 10 0.0 PPM
0	Next Page		90695 counts
			H2O 0 - 100 0 PPM
			2049737 counts
			5 Next

Options of Configuration Menu Page 2:

Time& Date: Used to set a date and time in the analyzer

Relay Open Active: (on or off) Used to set the state of active relay. If set to “on” active relay will be open. If set to “off” active relay will be off.

IP Address: Shows the IP address of the instrument when it is connected to a network. (Used to make software update or remote connection). When the Instrument isn’t linked to a Network, it shows Error getting an IP address.

Software Version: Gives the Software version installed in the instrument

Calibration	Configuration	Alerts	Helium
Configuration			N2 0 - 10
1	Time & Date	1998332	0.0 PPM counts
2	Relay open active: Off	118044	02 0 - 10
			0.0 PPM counts
			CnHm 0 - 10
			0.0 PPM counts
			120978 counts
			H2O 0 - 100
			32 PPM counts
			2731395 counts
0	Previous Page	5	Next

8.3 Alerts menu

This menu is used to monitor each alerts happening in the analyzer. When an alert is active, it will be shown and will disappear when resolved. The history alerts is used to review the last 50 alerts resolved. By pressing 1, you can toggle between active and historic alarms

Example of active alerts

Calibration	Configuration	Alerts	Helium
Active Alerts			N2 0 - 10
		2004/10/27 11:02 HCD Temp Deviation	0.0 PPM counts
		2004/10/27 11:02 Low Flow 3	1950541 counts
		2004/10/27 11:02 Low Flow 2	02 0 - 10
		2004/10/27 11:02 Low Flow 1	0.0 PPM counts
			58919 counts
			CnHm 0 - 10
			0.0 PPM counts
			60426 counts
			H2O 0 - 100
			0 PPM counts
			1361416 counts
1	Show Alerts History	5	Next

Example of alerts history

Calibration	Configuration	Alerts	Helium
Alerts History			N2 0 - 10
		2004/10/27 11:02 HCD Temp Deviation	0.0 PPM counts
		2004/10/27 11:02 Low Flow 3	1950593 counts
		2004/10/27 11:02 Low Flow 2	02 0 - 10
		2004/10/27 11:02 Low Flow 1	0.0 PPM counts
			58904 counts
			CnHm 0 - 10
			0.0 PPM counts
			75573 counts
			H2O 0 - 100
			0 PPM counts
			1701386 counts
1	Show Active Alerts	5	Next

The alerts possible are :

Low flow 1	Alarm N2 #1	Range overscale N2	Alarm H2O #1
Low flow 2	Alarm N2 #2	Range overscale O2	Alarm H2O #2
Low flow 3	Alarm O2 #1	Range overscale H2O	Alarm CnHm #1
Low flow 4	Vacuum P. Deviation	High cnHm level	N2 threshold exceed
Detector off	Alarm O2 #2	Range overscale CnHm	Alarm CnHm #2
Low Flow N2	High Flow N2	H2O threshold exceed	

The system status dry contact will be activated by those alerts only:

- Detector off
- Low Flow 1 (when the sample flow goes below 10 ml/min)
- Low Flow 2 (when the sample flow goes below 10 ml/min)
- Low Flow 3 (when the sample flow goes below 10 ml/min)
- Low Flow 4 (when the sample flow goes below 10 ml/min)
- N2 Low Flow (when the N2 flow is 2 ml/min lower than N2 flow setpoint)*Optional*
- N2 High Flow (when the N2 flow goes 2 ml/min higher than N2 flow setpoint)*Optional*
- HighCnHm level (When the CnHm reading is higher than CnHm threshold protection)
Optional

Alarm1 contact : Contact activated when process value of one impurity or more exceed the level 1 alarm set in Alarm settings Menu. One contact is available for all 4 impurities.

Alarm2 contact : Contact activated when process value of one impurity or more exceed the level 2 alarm set in Alarm settings Menu. One contact is available for all 4 impurities.

8.4 Range menu

When select button is pressed on the keypad, the range choice menu is displayed. This menu is used to select the range for each impurity. Each impurity can have it own range. They are all independent and there are 2 ranges per impurity. The range in bold is the actual range and when one of the button is pressed, the next range displayed will be selected and become the actual range. To quit this menu, just press the menu button.

Calibration	Configuration	Alerts	Helium
Range Choice			N2 0 - 10
N2 Range: 0 - 10			0.0 PPM
1	Next range: 0 - 100		975324 counts
O2 Range: 0 - 10			O2 0 - 10
2	Next range: 0 - 100		29540 counts
CnHm Range: 0 - 10			CnHm 0 - 10
3	Next range: 0 - 100		0.0 PPM
H2O Range: 0 - 100			30237 counts
4	Next range: 0 - 10		H2O 0 - 100
0	Previous Page		0 PPM
			692306 counts
			5 Next

8.5 Administration menu

This menu configures many parameters of the analyzer that should be **changed only by qualified personnel**. Those parameters can change the functionalities of the analyzer. To get into this menu, press 967 from the alerts menu.

Page 1:

Software Gain: Used to adjust the gain set by the software on each impurity independently. This value is set in Factory and must never be changed without advising LDetek.

PID Set Up: Used to adjust the PID parameters for the automatic sample flows.

Lock Range: (on or off) The range can be locked by the administrator. When ON, the user cannot change range manually. It will be fixed to the actual range in use.

Auto Calibration: (on or off) Used to active auto calibration (option)

Integrated Sample System : (on or off) Used to active or deactivated integrated sampling system (option)

Zero cal. flow setpoint: Use to set the set points of the different gas path when in ReZero process with the zero gas free option activated (option)

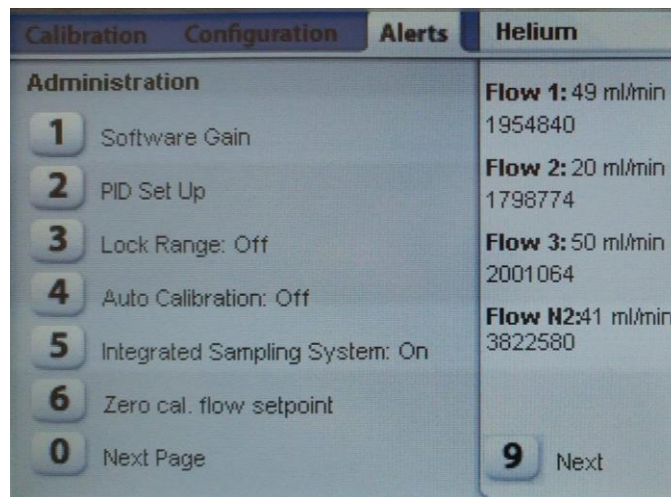



Plasma Power 1 and 2: Power sent to the detectors. Changing this value can result in severe damage to the Detector Module. **This value is set in Factory and must never be changed without advising LDetek.**

4-20mA Calib: This is used to calibrate the 4-20 mA or any system connected to the analyzer. Please refer to the detailed 4-20mA Calibration Procedure shown in this manual to proceed to a 4-20mA Calibration.

4-20 mA Test: This is used to test the 4-20mA output. It is also used to test if the 4-20mA output is well calibrated. Please refer to the detailed 4-20mA Calibration Procedure shown in this manual to proceed to a 4-20mA Calibration.

Starting counts: Used to determine the level where the detector is considered to be ON or OFF. This value is set in factory. **This value is set in Factory and must never be changed without advising LDetek.**

Zero free Purge time: Used to fix time in second of zero gas purge before the Zero calibration can be memorized.

Calibration	Configuration	Alerts	Helium
Administration			
1	Plasma Power 1: 40		Flow 1: 50 ml/min 1956394
2	Plasma Power 2: 40		Flow 2: 20 ml/min 1798570
3	4-20mA Calib		Flow 3: 50 ml/min 1998440
4	4-20mA, Test		Flow N2: 41 ml/min 3817142
5	Starting Counts: 0		
6	Zero free Purge time		
0	Next Page		9 Next

Page 3:

Serial Option: Toggle among the different serial communication mode.(option)

Off: The serial port is not used.

Send Status Only: Send an ASCII string on the serial port every second. See section 10.1 for more details.

Remote Ctrl Only: Active the Modbus/Profibus protocol on the serial port.

Remote Ctrl + Send Status: Send the ASCII string and active the Modbus/Profibus protocol.

Station Address: Enter a number between 1 and 254. The devices will only respond to Modbus request having this number. (option)

Background Setting: It is used to set the background that the unit can work (Argon, Helium or Argon /Helium). The analyzer cannot work on a background that has not been tuned in factory. **This value is set in Factory and must never be changed without advising LDetek.**

Vacuum Alarm Deviation: Used to adjust the allowable deviation from the “vacumm setpoint” before the vacuum alarm appears. The “ Vacuum P. Deviation “ alarm will be activate when the vacuum reading is over or lower the setpoint +/- the Deviation. Ex: lower than 150 mbar and higher than 250 mbar in the settings of the picture bellow. (Just for system with optional pump)

Vacuum Alarm SetPoint: Use for set point of vacuum alarm. (Just for system with optional pump)

Display Vacuum: Used to activate the vacuum sensor reading shown at 4th page of Real time menu. (option)

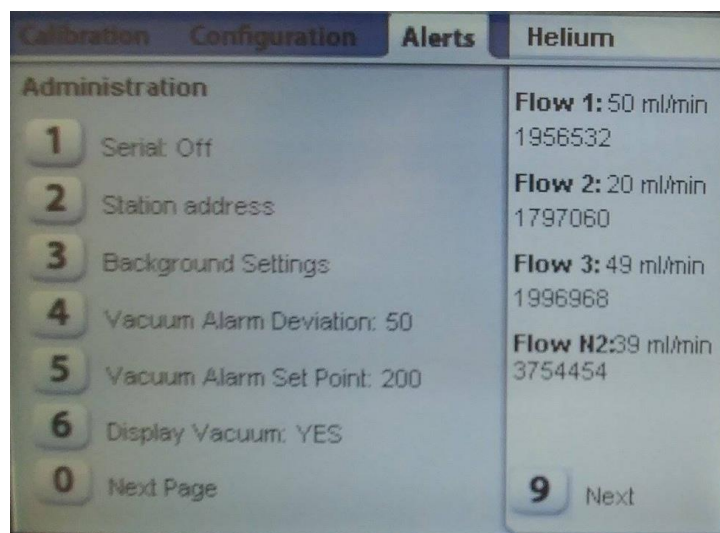

Page 4:

Purifier temp Setpoint: Used to enter the temperature setpoint (in degree Celsius) of the internal purifier when used for a Zero calibration.

Zero gas free : (on or off) Used to enable the zero gas free option. (optional)

Background Mix: Used to correct the linearity of the sensors as a function of the level of helium vs Argon. Only used for analyser that run with a mix of Ar/He as balance gas. This value is set in Factory and must never be changed without advising LDetek.

Trap Protect threshold: Used to set the treshold value for N2 or H2O measurement before to switch to protection mode for CnHm trap protection (cut flow in this measurement path) . If the value is zero, the threshold is not considered like active. (option)

Doping Gas: (on or off) Used to enable the doping gas option and have a Flow N2 reading at page 2 of Realtime menu. (option)

Doping Gas set point: If the doping gas option is activated, this menu will be used to enter the setpoint of N2 flow. An alarm will appear if the actual N2 flow deviate higher or lower than 2 ml/min from this setpoint.

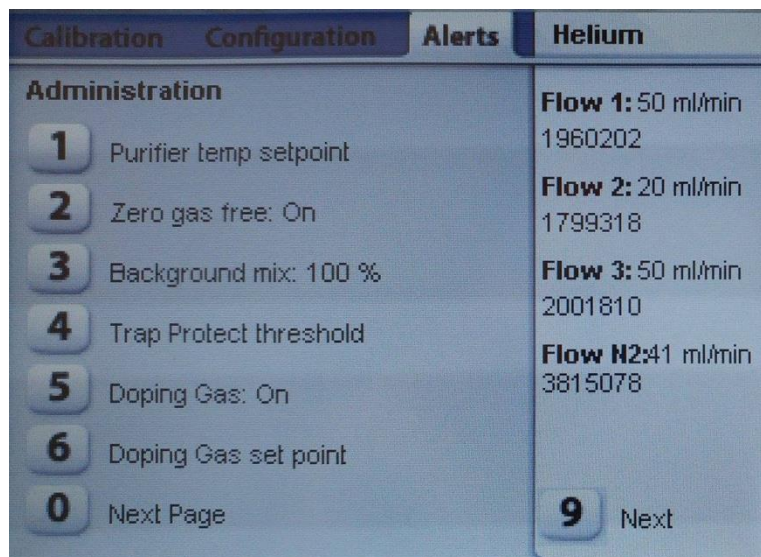

9. Drawings & Schematics

9.1 Parts Identification (4U)

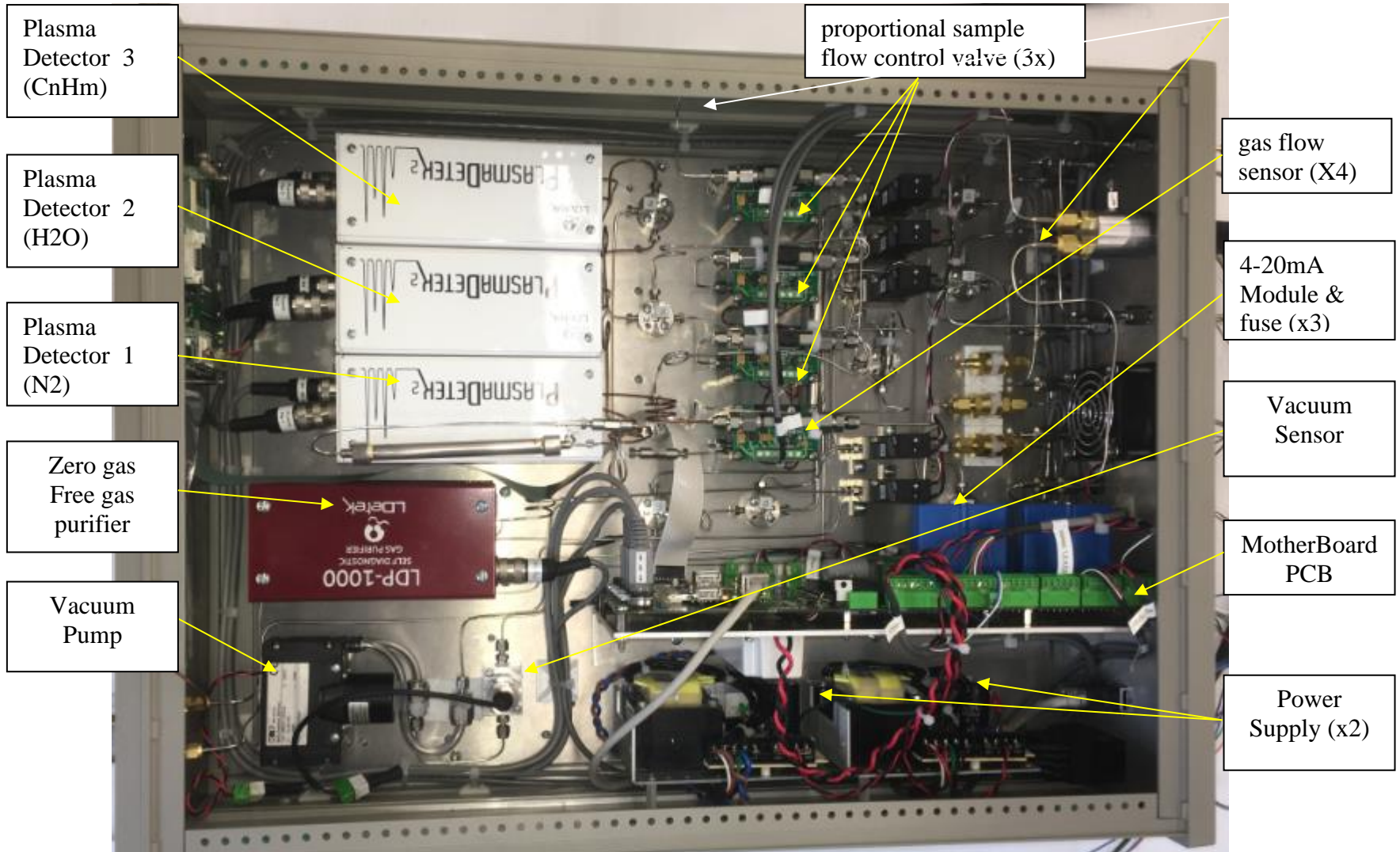

9.2 Parts Identification (3U)

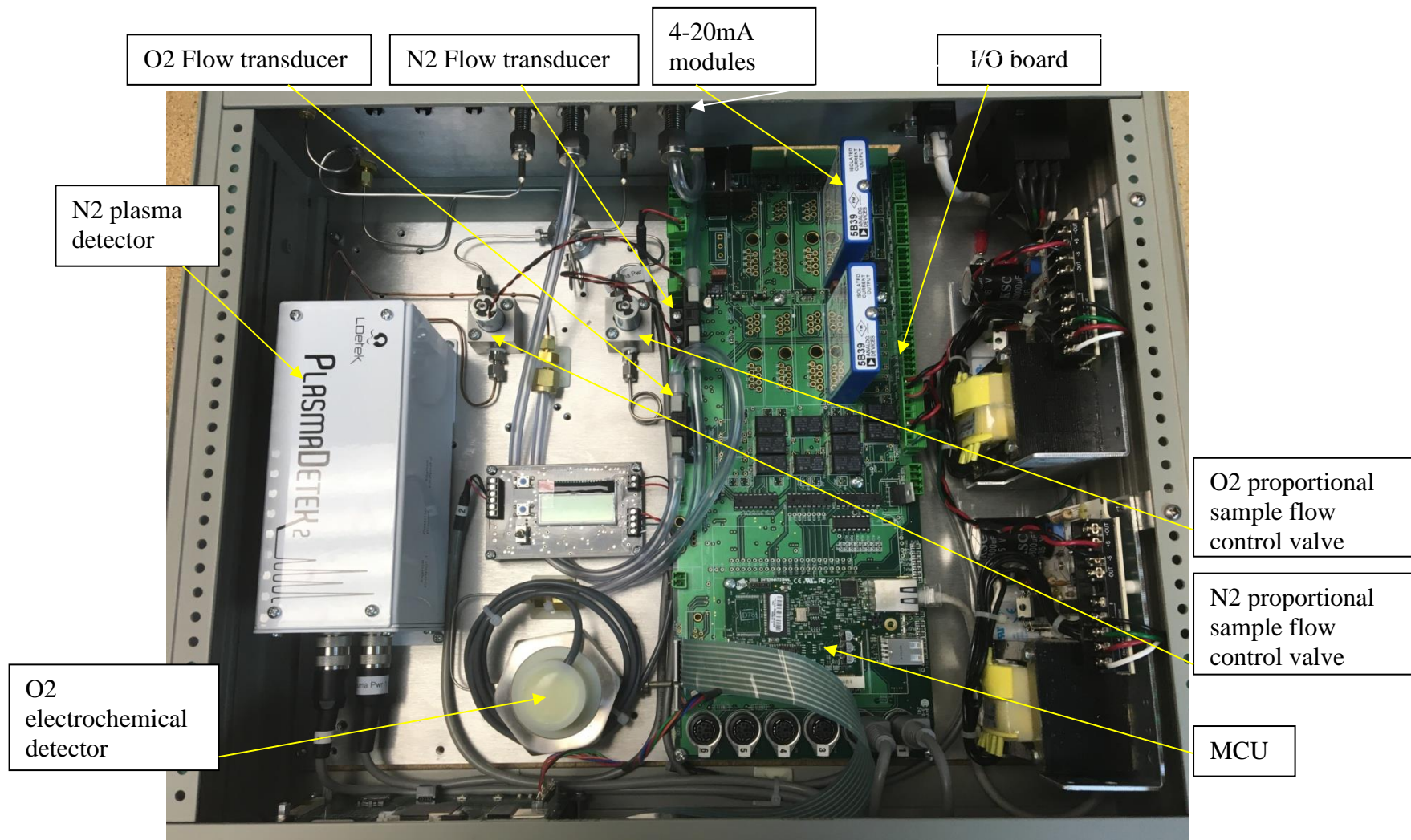

9.3 Back Panel Identification (3U)

KEEP IT AT ATMOSPHERIC PRESSURE. PRESSURIZING THE VENT WILL CAUSE SEVERE DAMAGE TO THE INSTRUMENT

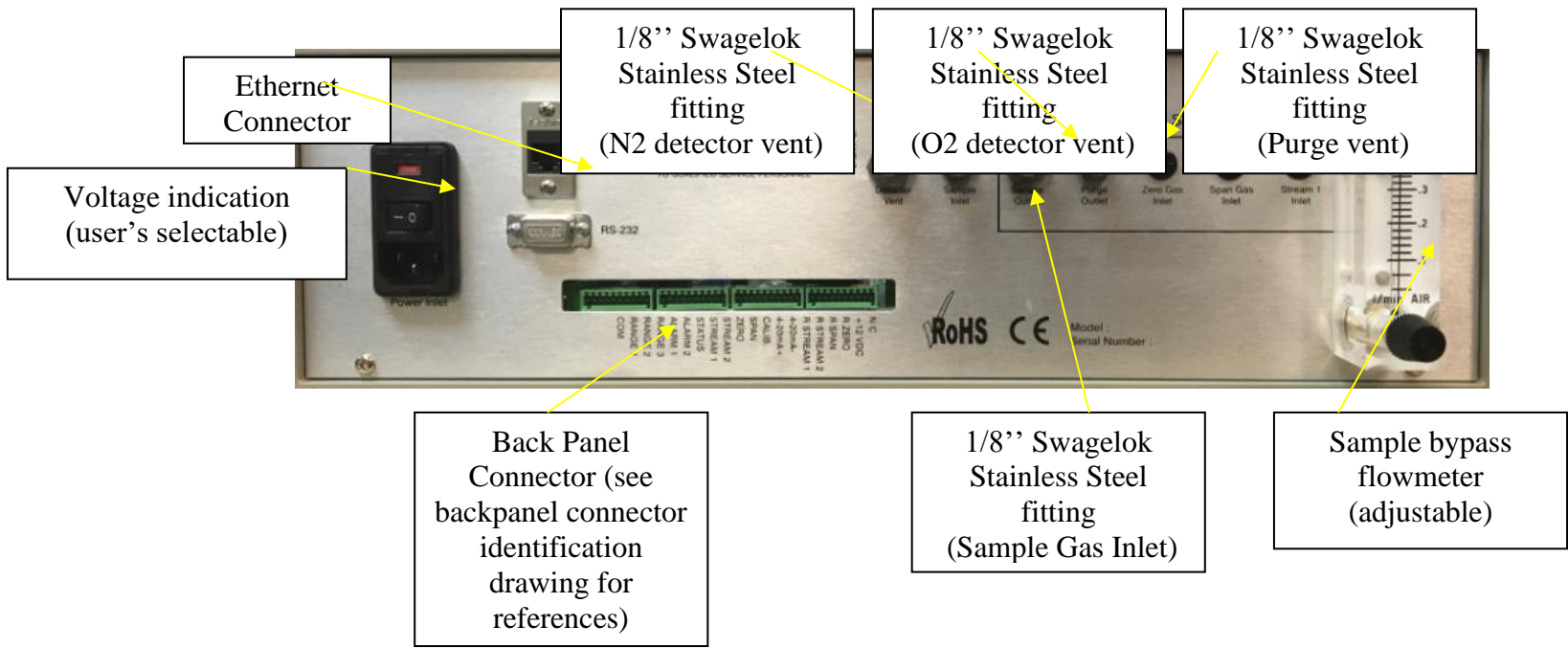

9.4 Back Panel Identification (4U)

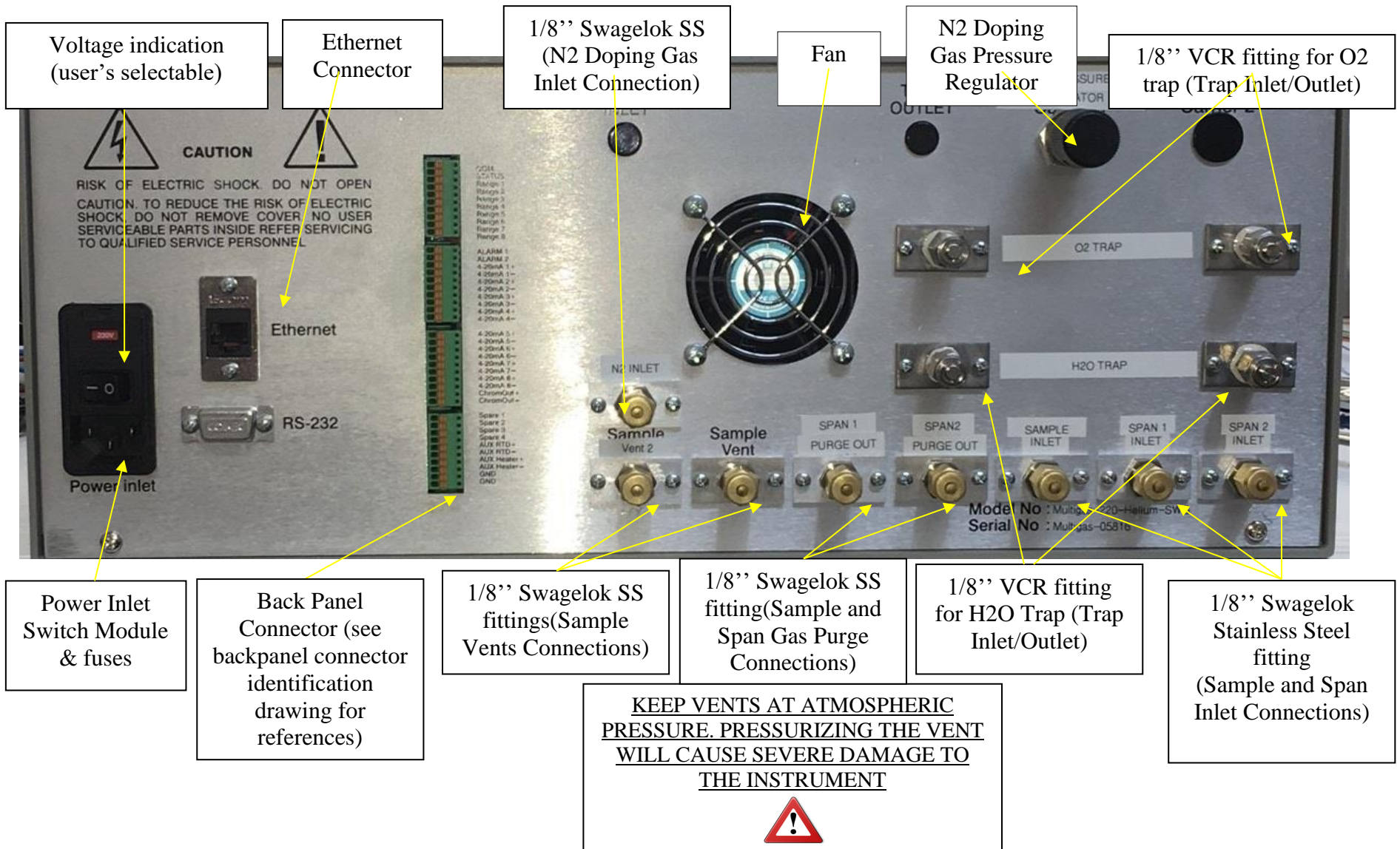

9.5 Back Panel Connector Identification (3U and 4U)

COM
STATUS
Range 1
Range 2
Range 3
Range 4
Range 5
Range 6
Range 7
Range 8
ALARM 1
ALARM 2
4-20mA1+
4-20mA1-
4-20mA2+
4-20mA2-
4-20mA3+
4-20mA3-
4-20mA4+
4-20mA4-
4-20mA5+
4-20mA5-
4-20mA6+
4-20mA6-
4-20mA7+
4-20mA7-
4-20mA8+
4-20mA8-
ChromOut+
ChromOut-
Spare 1
Spare 2
Spare 3
Spare 4
AUX RTD+
AUX RTD-
AUX Heater+
AUX Heater-
GND
GND

COM : All dry relay contacts share this common terminal

STATUS : This dry contact is open when a critical alarm is active

*RANGE 1: Contact to indicate the selected measuring range for first impurity measured

*RANGE 2: Contact to indicate the selected measuring range for second impurity measured

*RANGE 3: Contact to indicate the selected measuring range for third impurity measured

*RANGE 4: Contact to indicate the selected measuring range for fourth impurity measured

*RANGE 5 / RANGE 6 / RANGE 7 / RANGE 8: N/A

ALARM1 : This dry contact is open when process value is higher than one of the alarm1 set values

ALARM2 : This dry contact is open when process value is higher than one of the alarm2 set values

4-20mA1+: Analog output positive terminal for first impurity measured

4-20mA1-: Analog output negative terminal for first impurity measured

4-20mA2+: Analog output positive terminal for second impurity measured

4-20mA2-: Analog output negative terminal for second impurity measured

4-20mA3+: Analog output positive terminal for third impurity measured

4-20mA3-: Analog output negative terminal for third impurity measured

4-20mA4+: Analog output positive terminal for fourth impurity measured

4-20mA4-: Analog output negative terminal for fourth impurity measured

4-20mA5+ / 4-20mA5- / 4-20mA6+ / 4-20mA6- / 4-20mA7+ / 4-20mA7- / 4-20mA8+ /

4-20mA8- / CHROMOUT+ / CHROMOUT- : N/A

SPARE 1 to SPARE 4: These dry contacts are spare contacts (Used for options only)

AUX RTD+ : RTD+ contact (used for auxiliary oven only)

AUX RTD- : RTD- contact (used for auxiliary oven only)

AUX Heater+ : Heater+ contact (used for auxiliary oven only)

AUX Heater- : Heater- contact (used for auxiliary oven only)

GND : This is a common GND (Used for options only)

GND : This is a common GND (Used for options only)

*By default the ranges dry contacts are open when Range 2 is selected. One contact is available for each impurity (Used with two ranges only)

As described at section 7.3 for menu configuration, the relays state can be changed if desired. 4 ranges relays are used in this instrument version for 4 impurities.

9.6 Piping Schematic (N2-O2-H2O-CnHm / 4U) with PED

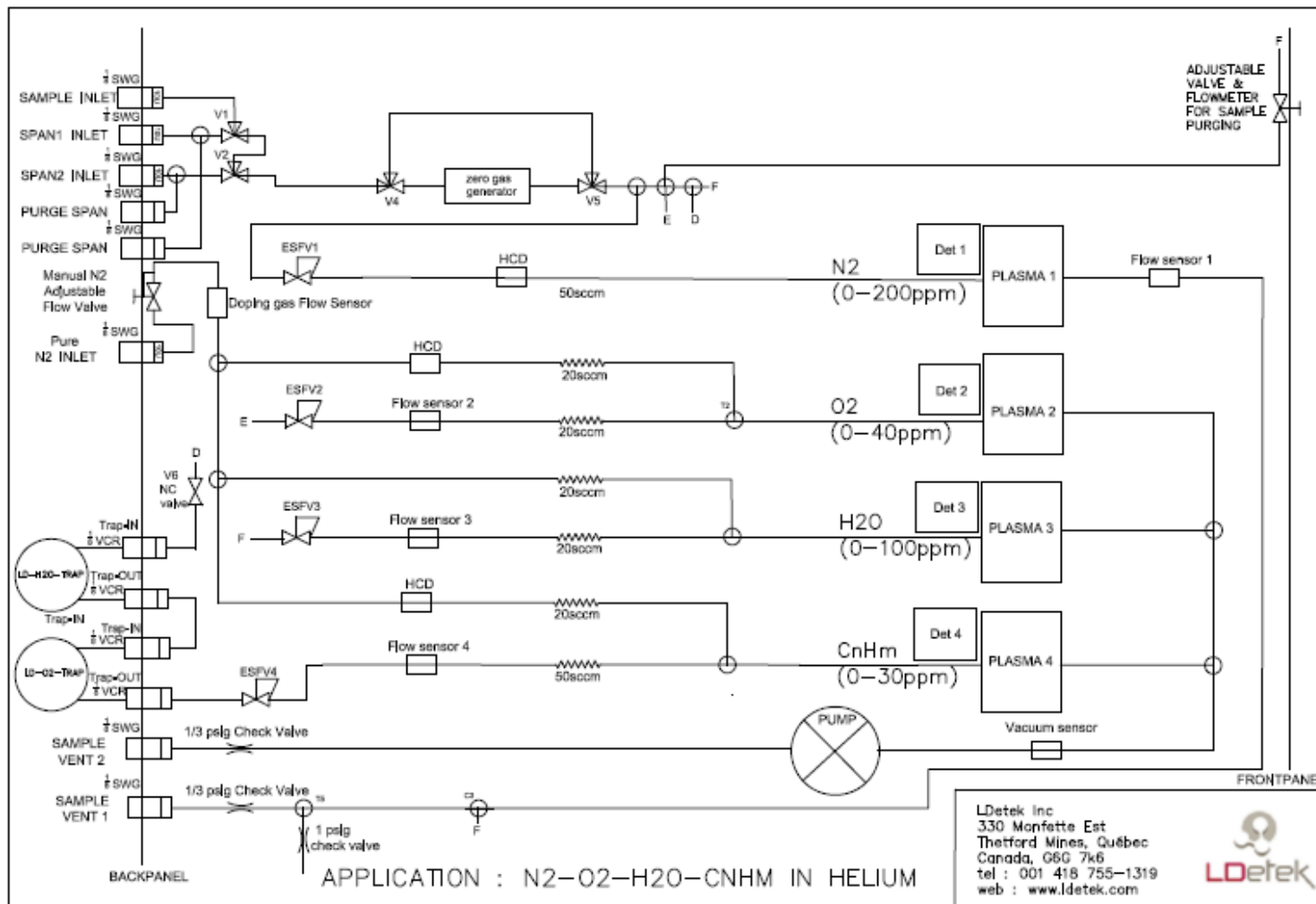

Options Included : Integrated stream selector, Zero gas free calibration, Sample bypass adjustable valve and flow meter

9.7 Piping Schematic (O2-N2 / 3U) with O2 electrochemical

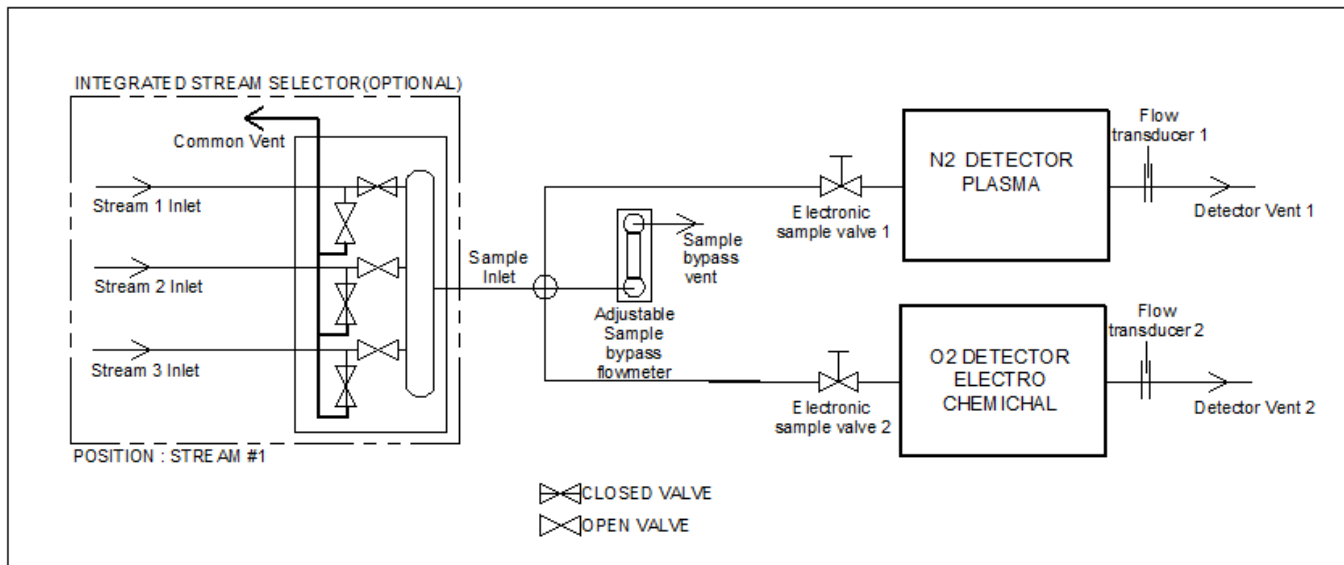

Optional: Integrated stream selector and Sample bypass adjustable valve and flow meter

9.8 Electrical Schematic (N2-O2-H2O-CnHm / 4U) with PED

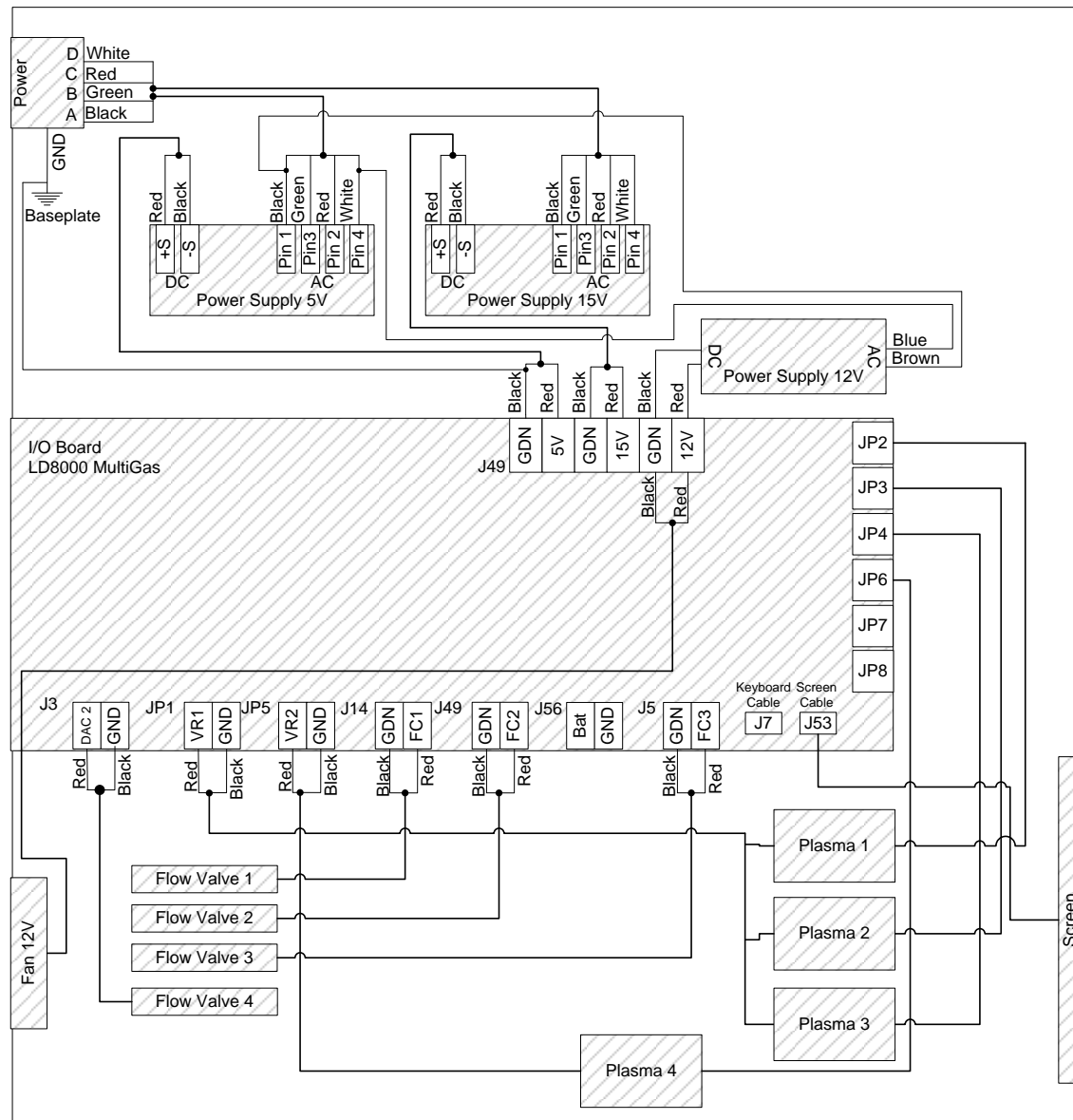

9.9 Electrical Schematic (N2-O2-H2O-CnHm / 4U) with O2 electrochemical

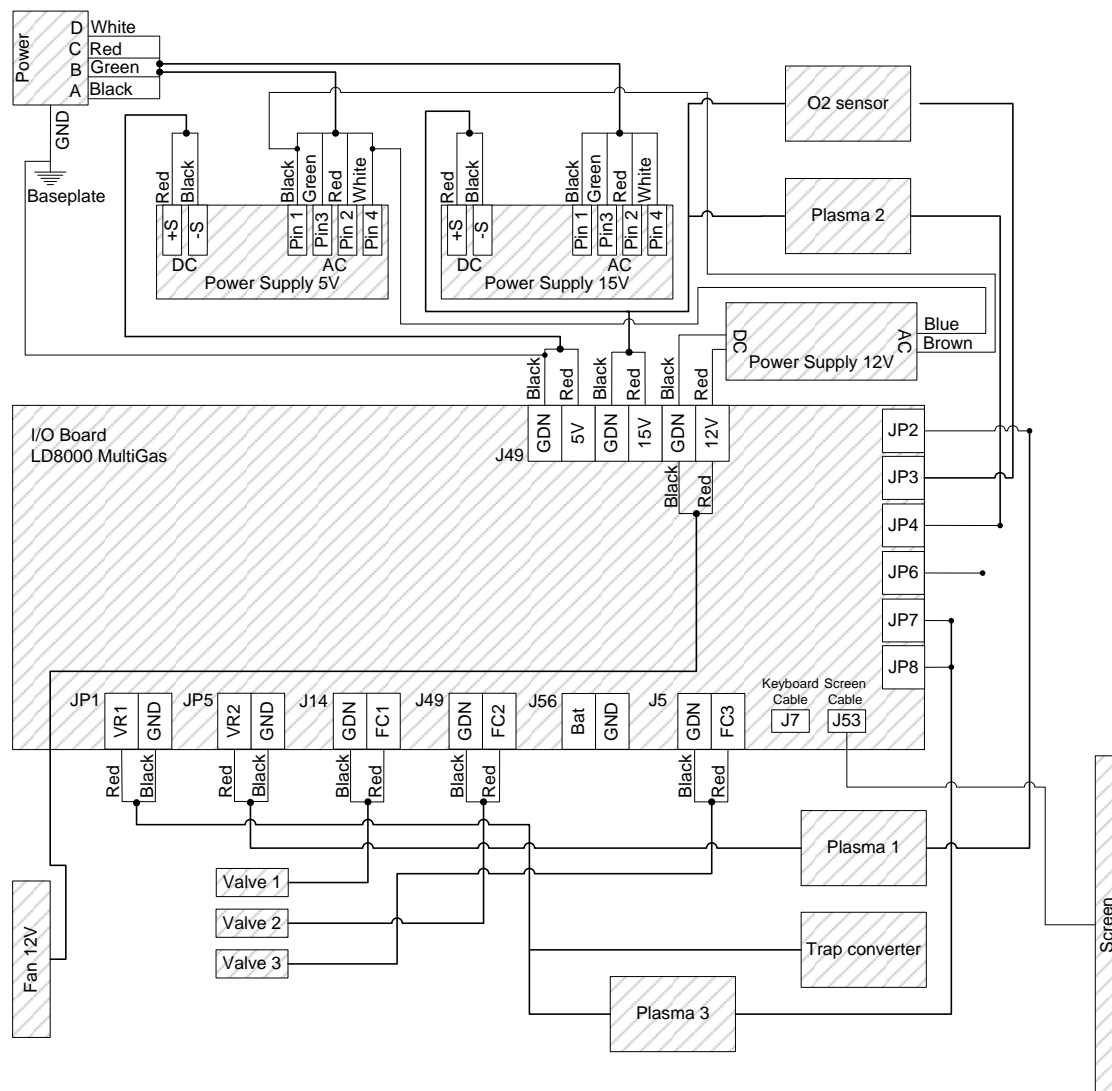

9.10 Electrical Schematic (O2-N2 / 3U) with O2 electrochemical

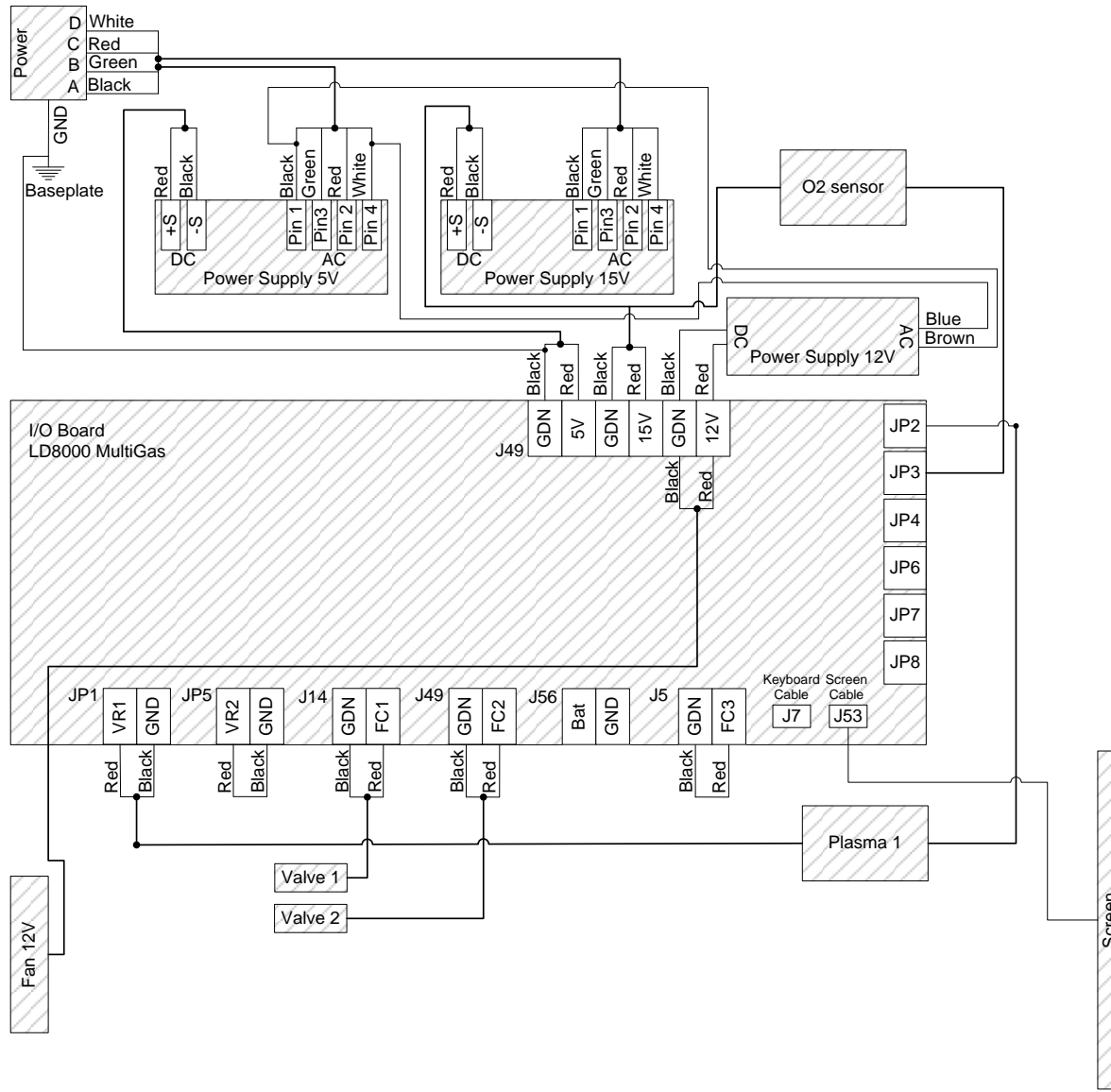

9.11 Enclosure Dimensions & Panel Cutout (4U)

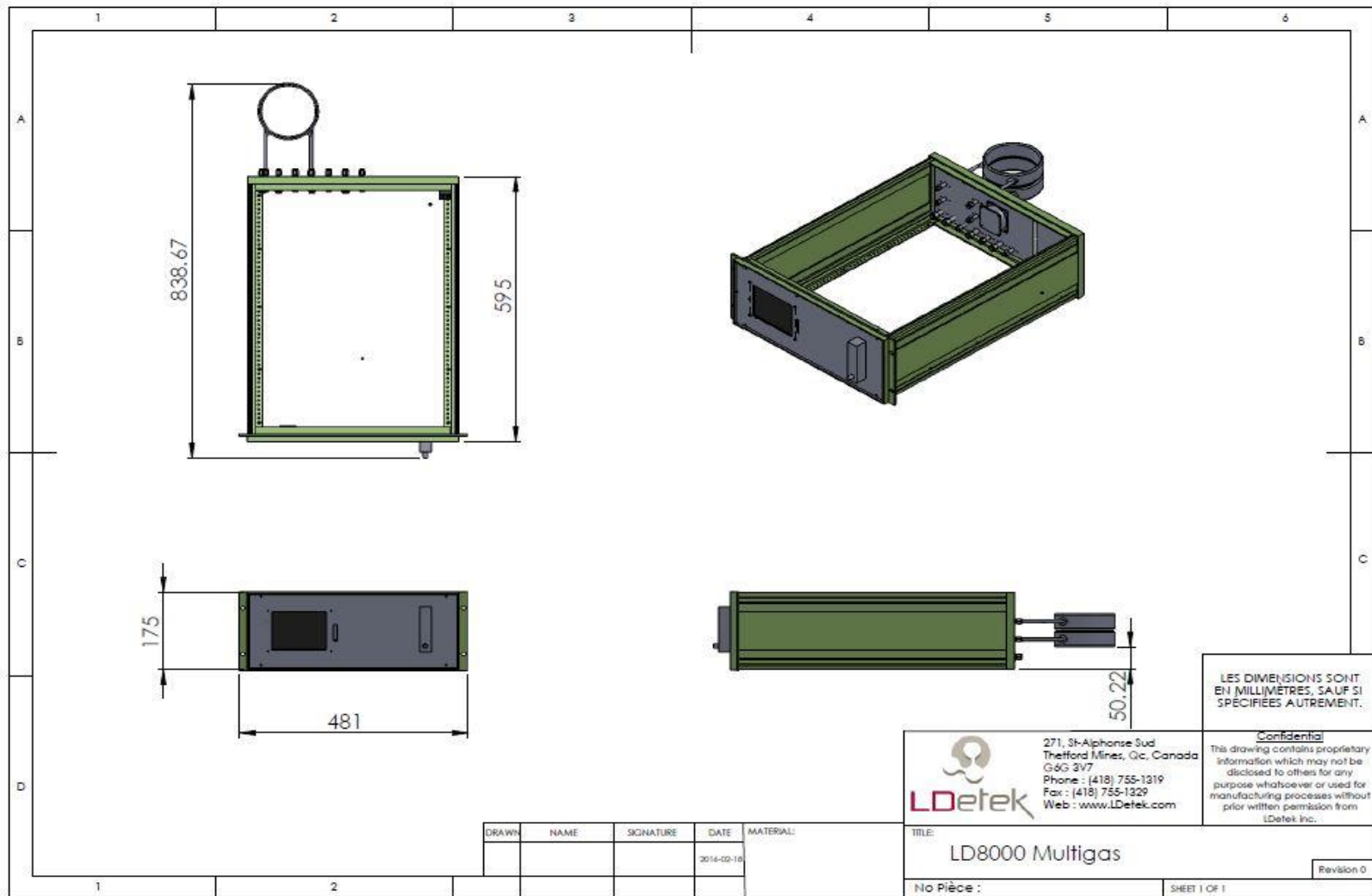

9.12 Enclosure Dimensions & Panel Cutout (3U)

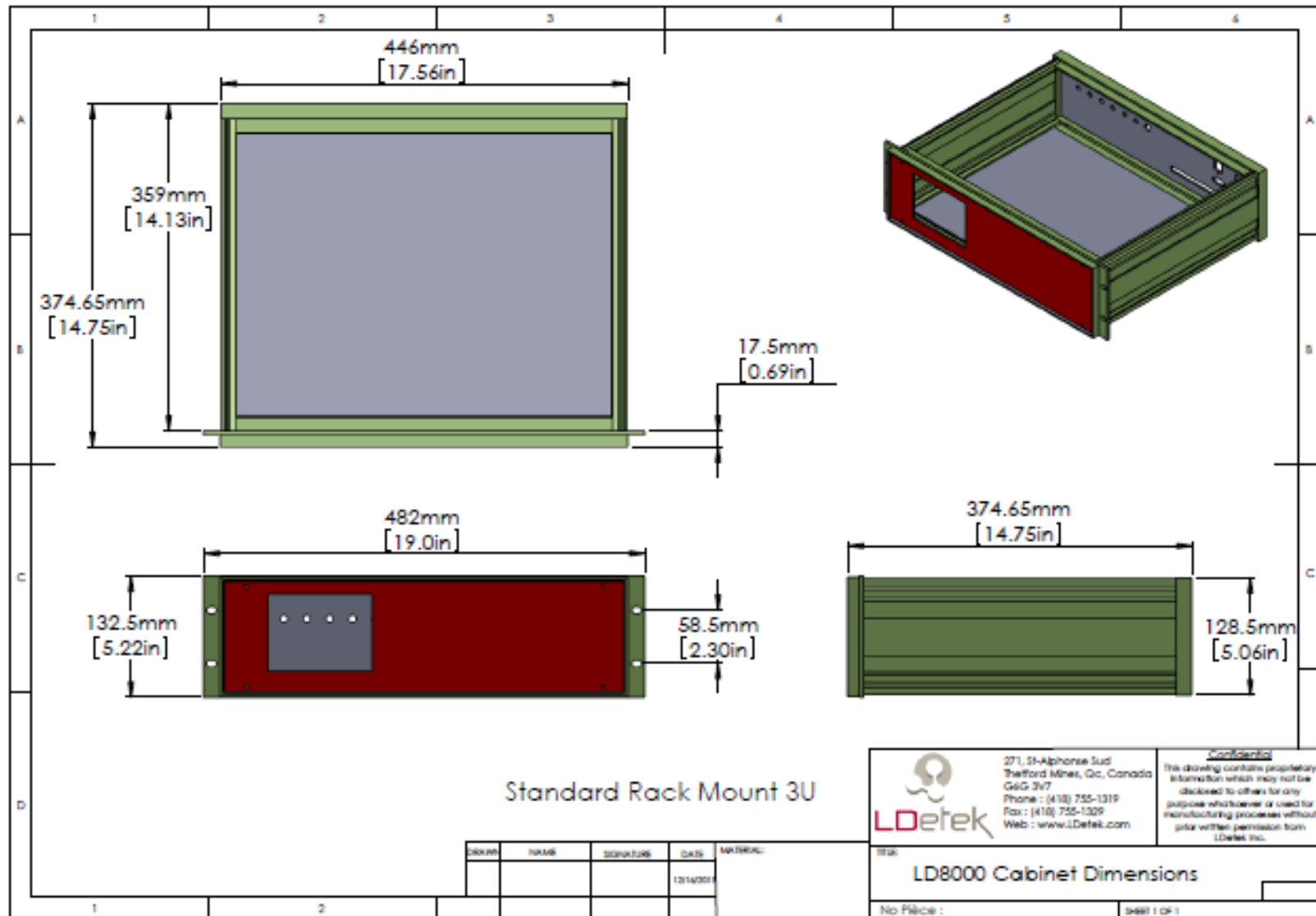

9.13 Back Panel Dimensions (4U)

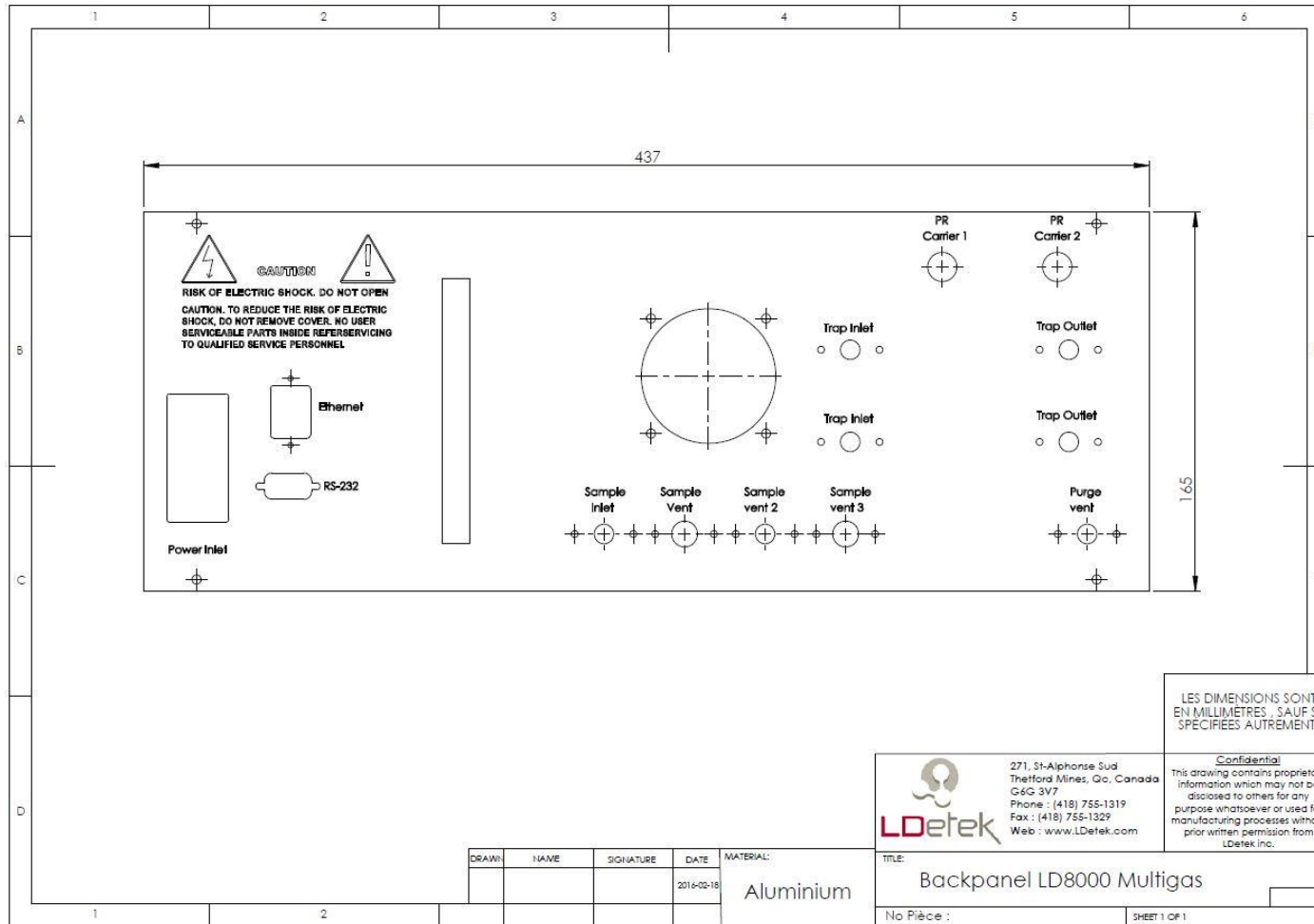

10.Procedures

This section will give important procedure to follow regarding some manipulation to do with the instrument and/or its different functions. It is strongly suggested to read it prior to the installation of the instrument.

10.1 Analog Output Calibration Procedure (4-20mA)

The Analog Output has already been calibrated by LDetek specialist prior to shipping. In normal conditions, the analog output doesn't have to be recalibrated on site. In the eventuality that the Analog Output has to be recalibrated, the procedure below explains how to proceed for the 4-20mA calibration

Step 1: Disconnect all cables connected to the 4-20mA1+ & 4-20mA1- terminals on the rear panel. Connect an Ampere meter set at DC mA to monitor the analog signal in current.



Step 2: In the menu Configuration, set the 4-20mA module in HOLD mode to allow the calibration process.

Calibration	Configuration	Alerts	Helium
Configuration			N2 0 - 10 0.0 PPM
1	4-20mA modules: Hold	1982452	counts
2	Sample Flow Set Point	O2 0 - 10 0.0 PPM	88530 counts
3	Automatic Ranging: Off	CnHm 0 - 10 0.0 PPM	90695 counts
4	Alarms Settings	H2O 0 - 100 0 PPM	2049737 counts
0	Next Page	5 Next	

Step 3: Go in the Administration menu by pressing button 9-6-7 from the Alerts Menu. Once you are in the Administration menu, press 0 than press 3 to get access to 4-20mA Calib.

Calibration	Configuration	Alerts	Helium
Administration			N2 0 - 10 0.0 PPM
1	Plasma Power 1: 20	629166	counts
2	Plasma Power 2: 20	O2 0 - 10 0.0 PPM	1021775 counts
3	4-20mA Calib	H2O 0 - 100 OS PPM	8386778 counts
4	4-20mA Test	CnHm 0 - 10 0.0 PPM	7036496 counts
5	Starting Counts: 0	9 Next	
0	Next Page		

Step 4: You have to select which Output you want to calibrate. Usually you should begin from 1st and finish by the last one. Press 1 for selection of first 4-20ma output calibration.

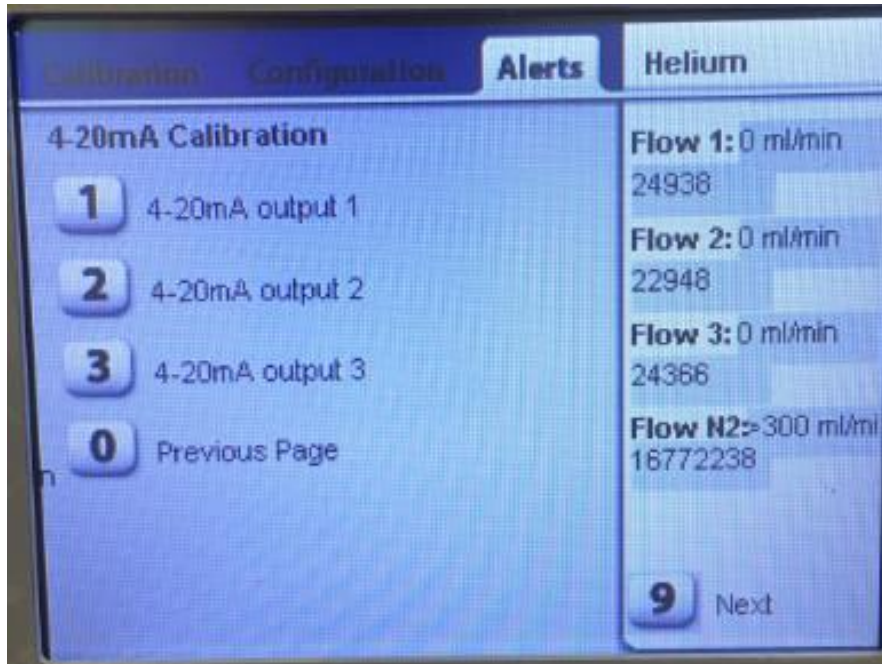

Step 5: It will now pop up a window that tells you to enter the measured value. You have to enter the value in mA that appears on the Ampere Meter and press Accept button.



Step 6: It will now pop up a new window that tells you to enter the measured value. You have to enter the value in mA that appears on the Ampere Meter and press Accept button.



Step 7: The calibration is now completed. To test it, you can now press the 4 button from the administration menu to get access to the 4-20mA test. By going in this menu, you can change as you want to mA value from 4mA up to 20mA to verify the accuracy of the 4-20mA Output1 to 4th by comparing the shown value on the screen with the shown value on the Ampere Meter.

Calibration	Configuration	Alerts	Helium
Administration			N2 0 - 10 0.0 PPM
1	Plasma Power 1: 20		629166 counts
2	Plasma Power 2: 20		O2 0 - 10 0.0 PPM
3	4-20mA Calib		1021775 counts
4	4-20mA Test		H2O 0 - 100 OS PPM
5	Starting Counts: 0		8386778 counts
0	Next Page		CnHm 0 - 10 0.0 PPM
			7036496 counts
			9 Next

At the end of it, be sure to set back the 4-20mA Module in the Configuration menu to Track. This is to make sure the measured values in real time are tracked.

10.2 Software Update Procedure

- 1) You need to connect a computer to the analyzer with a FTP client. To do that uses a FTP client like Core FTP. (download on www.coreftp.com)
- 2) Connect an Ethernet cable to your analyzer on your server. You can retrieve the analyzer IP in the configuration menu.
- 3) Open your FTP client (the screen below will then appears)
 - Enter the IP address of the analyzer in the field "Host/IP/URL" to connect to the analyzer
 - You will need to enter the username and the password to be able to connect to the analyzer. The username is **root** and the password is **password**. Then click on connect.

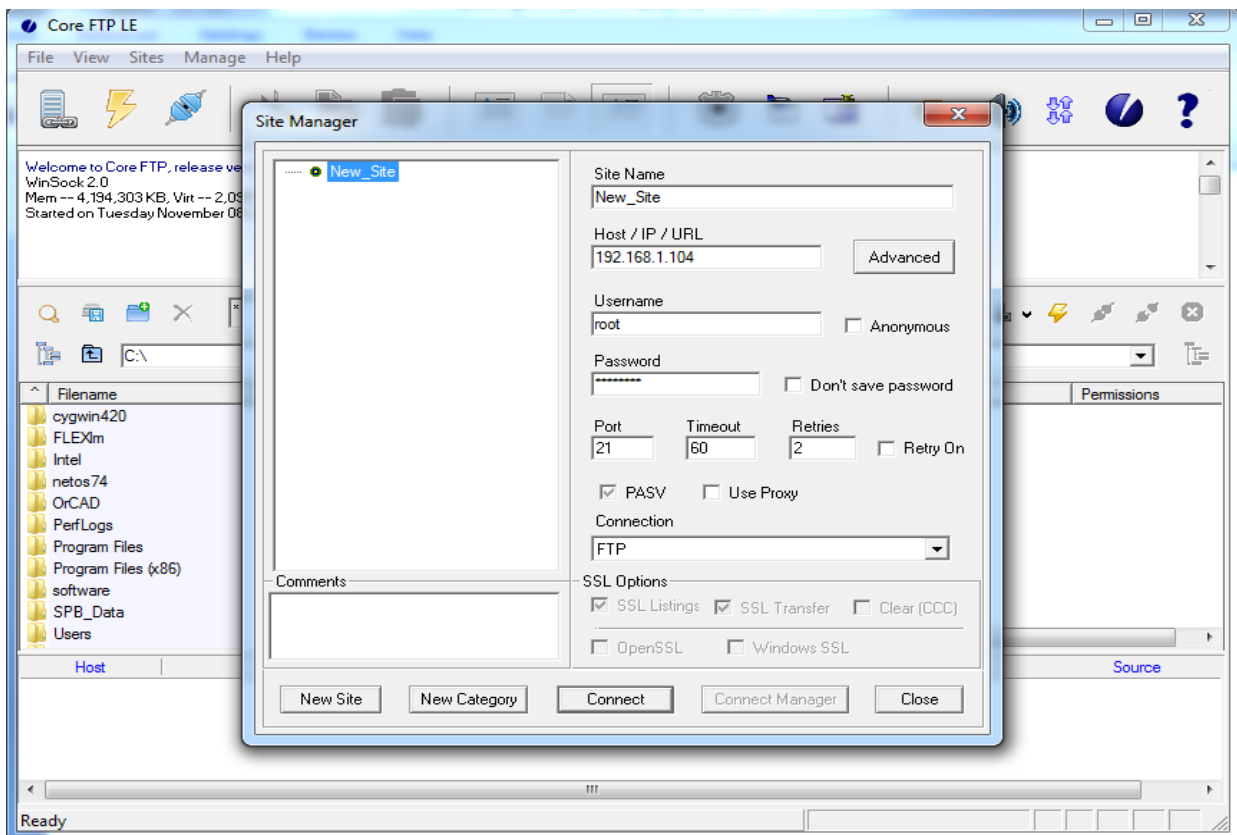

- 4) When you are connected to the analyzer (the screen below will then appears),
- 5) You now have to upload the image.bin to the analyzer:
 - First select the new file "image.bin" then click on upload button.

It is important to not modify the other files .ini in the analyzer. These are the configuration files.

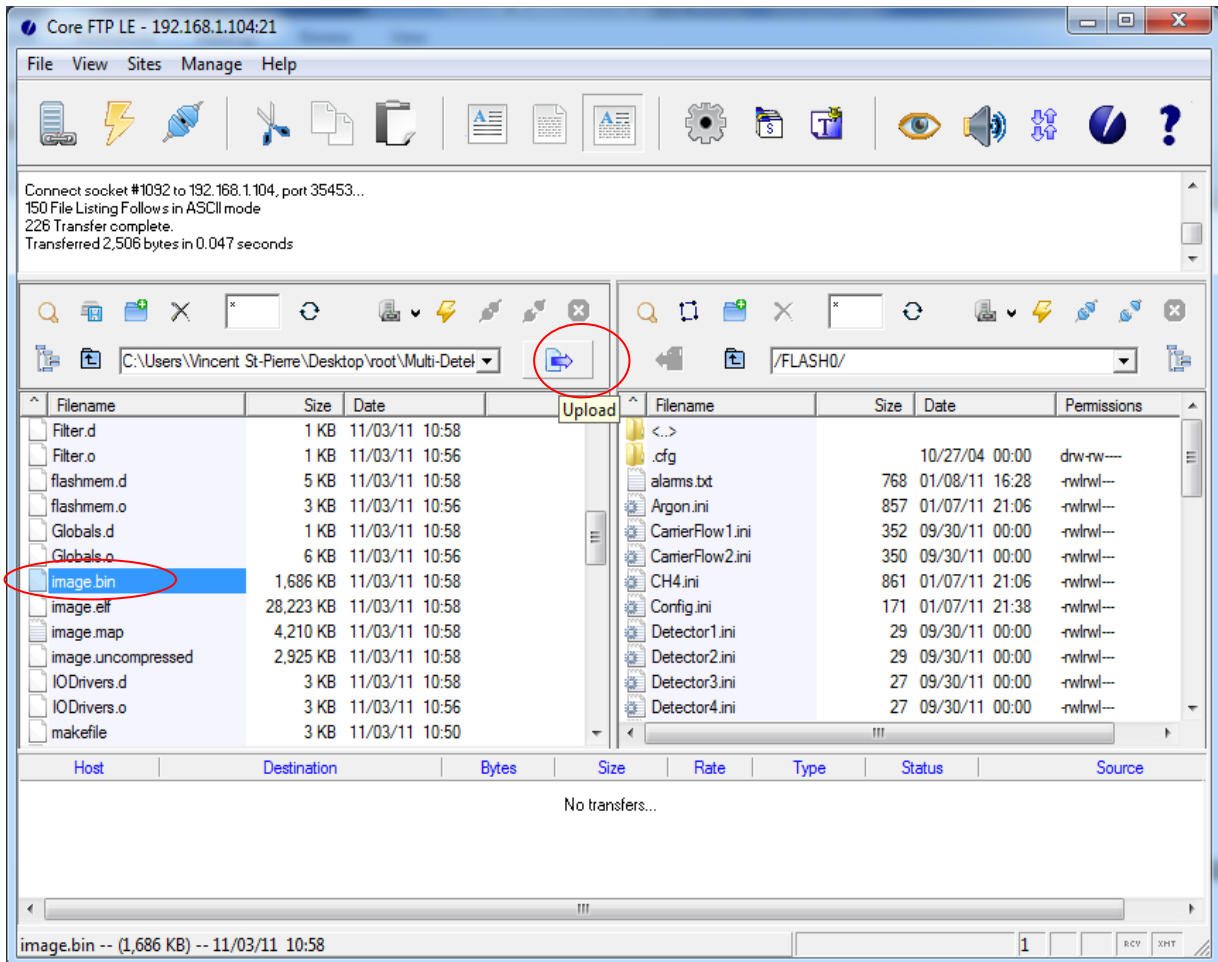

- 6) After the file is uploaded, just disconnect your FTP connection to the analyzer by clicking File/disconnect. Then the analyzer will restart automatically after 1 minute. And the software update is finish.

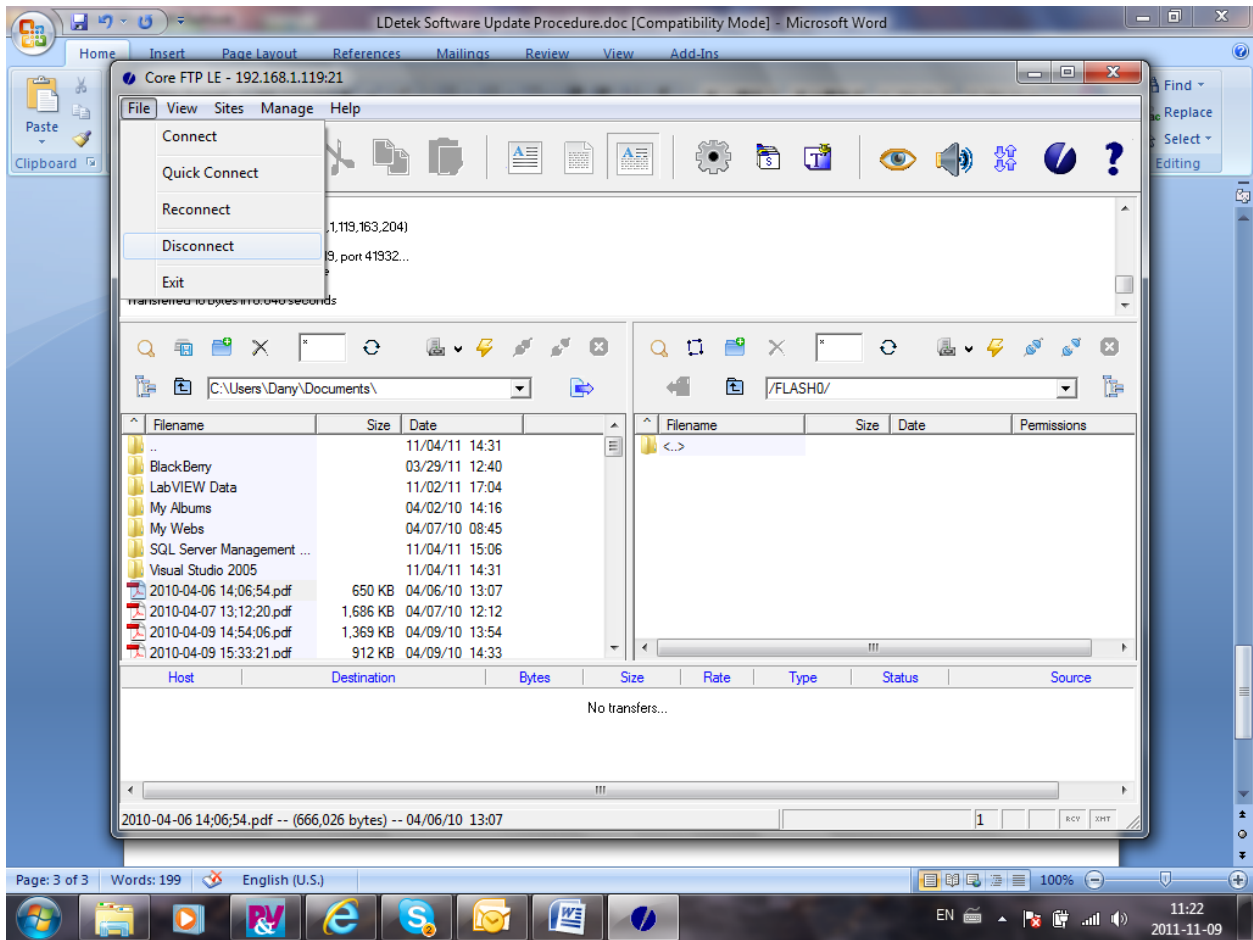

10.3 Oxygen Electrochemical cell installation at reception

- 1) Make sure that there is a sample gas connected at analyser sample inlet and gas pressure is inside the specifications of the analyser.
- 2) Make sure that the analyser has flows of sample gases that are equal to sample setpoints. The LD8000 Multigas can have 2 or 3 sample gas paths.

Press "9" button until you see "Flow 1: / Flow 2:" flow sensors readings at right of screen.

Make sure that the flow reading values are the same than in "Configuration" tab and "Sample Flow Setpoint" option.

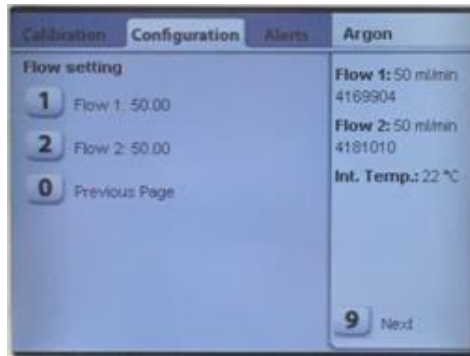

- 3) Open the LD8000 Multigas top cover by unscrewing the 2 top right and the 2 top left phillips screws.

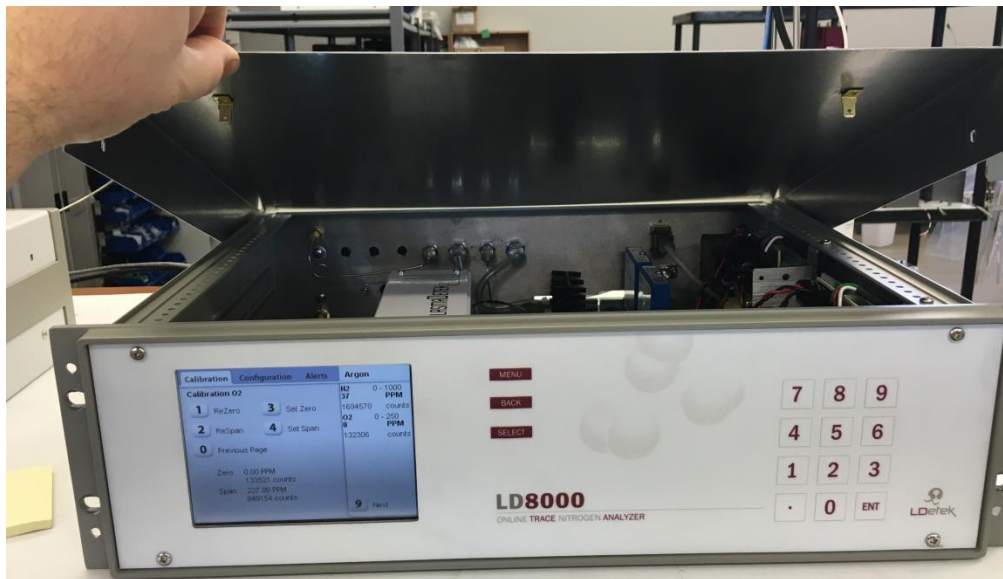

- 4) Unscrew (counterclockwise) the Electrochemical O2 sensor nut by hand. All this without twisting the center white plastic part. Only the metal nut should turn.

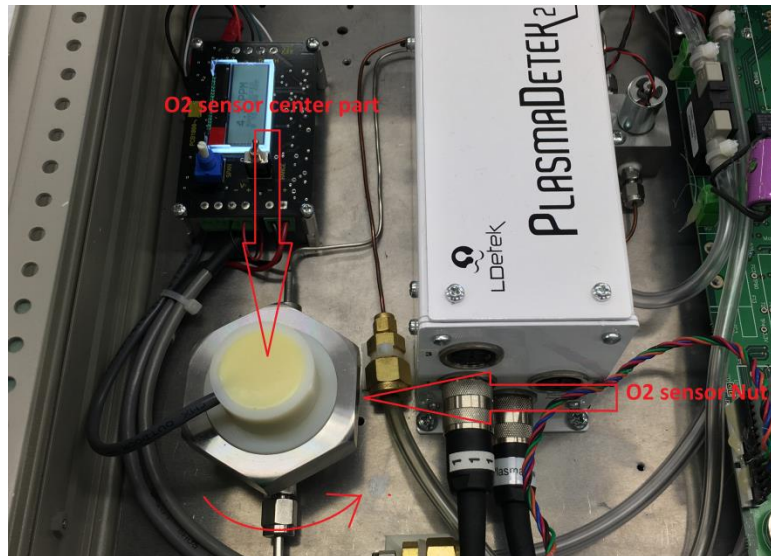

- 5) Release the nut and center part from the O2 sensor manifold part (it can only be disassembled once the nut is fully unscrewed).

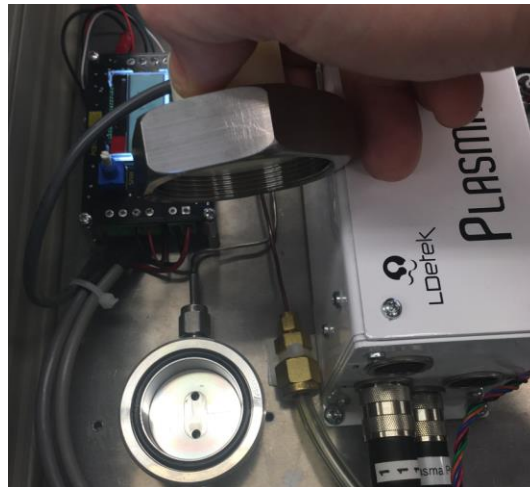

- 6) Remove the O2 sensor electrochemical cell from the Vacuum package and install it in the O2 sensor manifold. Grill part of the Cell should face the manifold and gold contacts should face up.



- 7) Re-install the Nut and center part together on the manifold. Screw-in the nut without twisting the center part (to no damage the cable). Tight the nut by hand. You can tight it until you feel that it's well tight (to avoid air leak).
- 8) Look at O2 reading results on LD8000 MultiGas front screen. It should start from around 21% and go down slowly until to reach the O2 span gas content. The purge time (stabilisation) of the O2 reading is dependant of sample flow setpoints, the time that the analyser was in storage and the time it took to install the O2 cell. It could take 1-2 days before to have a stable and precise O2 reading (this, only at start-up of the instrument).

11.Options

11.1 RS232/RS485/Profibus communication

The RS-232 option is used to monitor the values and the status of the analyzer. A female DB-9 connector is available on the back of the LD8000 when the option is installed.

Baud rate: 9600, 19200, 38400, 57600 bauds (see section 7.5, admin menu, page 4)

The string coming out of the serial port is ASCII. Here is the structure:

station address (this value is not ASCII, it is a byte and could be 0 as well)

TAB

ppm value

TAB

Range used (1-2 or 3)

TAB

Sample flow

TAB

Ambient temperature

TAB

Status Byte

TAB

Current active stream

Carriage Return

Here is the structure for the status byte:

- Bit 1 : status
- Bit 2 : low sample flow
- Bit 3 : detector off
- Bit 4 : overscale
- Bit 5 : alarm 1
- Bit 6 : alarm 2
- Bit 7 : calib in progress

The string is sent at every second.

A RS-485 communication can also be available by installing a RS-232 to RS-485 converter module. The RS-485 can then be accessible by connecting the TX and RX wires in the terminal block of the converter module mounted on the back panel of the analyzer. The module is powered by the analyzer itself. No need to bring external power source. See on the image below a typical installation.

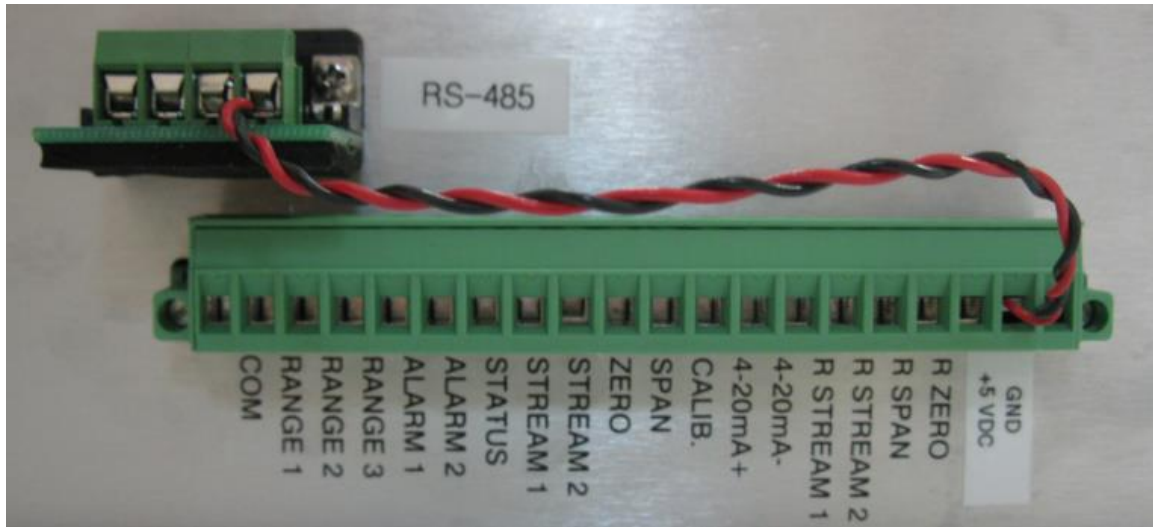

RS-485

A compact RS-232 to Profibus serial gateway can also be mounted on the back panel of the LD8000. The unit is housed in a 2 ½” x 3 ¼” plastic housing. A standard DB9-Female connector provides the Profibus interface and a DB9-Male connector provides the RS232 interface.

The Profibus channel is fully isolated from the supplied power. The power is conditioned by a loss-of-ground protection circuit. The power source is feed by the LD8000. No need of external power source is required. The RS232 serial stream is internally buffered allowing a Master node to send and receive data using standard Profibus messaging.

The module provides a fully buffered serial interface between Profibus and peripheral devices. Internal FIFO's, buffer up to 255 bytes for both receive and transmit data, easing the interface for slower RS232 based devices. Hardware or software flow control is supported. See on the image below our RS-232 to Profibus converter module.

Features & Benefits:

- Fully isolated Profibus channels
 - Powered from 11-28 VDC supply
 - Rotary hex switches for unit node address
 - 2 Bi-Color LEDs for module status
 - 2 Bi-Color LEDs for serial channel status
- Control & Information



Profibus module

11.2 Integrated stream selector & auto calibration

The integrated stream selector is used for selecting the desired stream from the LD8000 Multigas interface. The compact stream selector system is mounted inside the LD8000 Multigas and is certified and tested for high purity. It can have up to 5 different streams. Mostly, one stream is used for zero gas, a second stream for span gas and the 3extra streams are user's selectable depending of the number of analysis streams. Please refer to the images below for piping diagram.

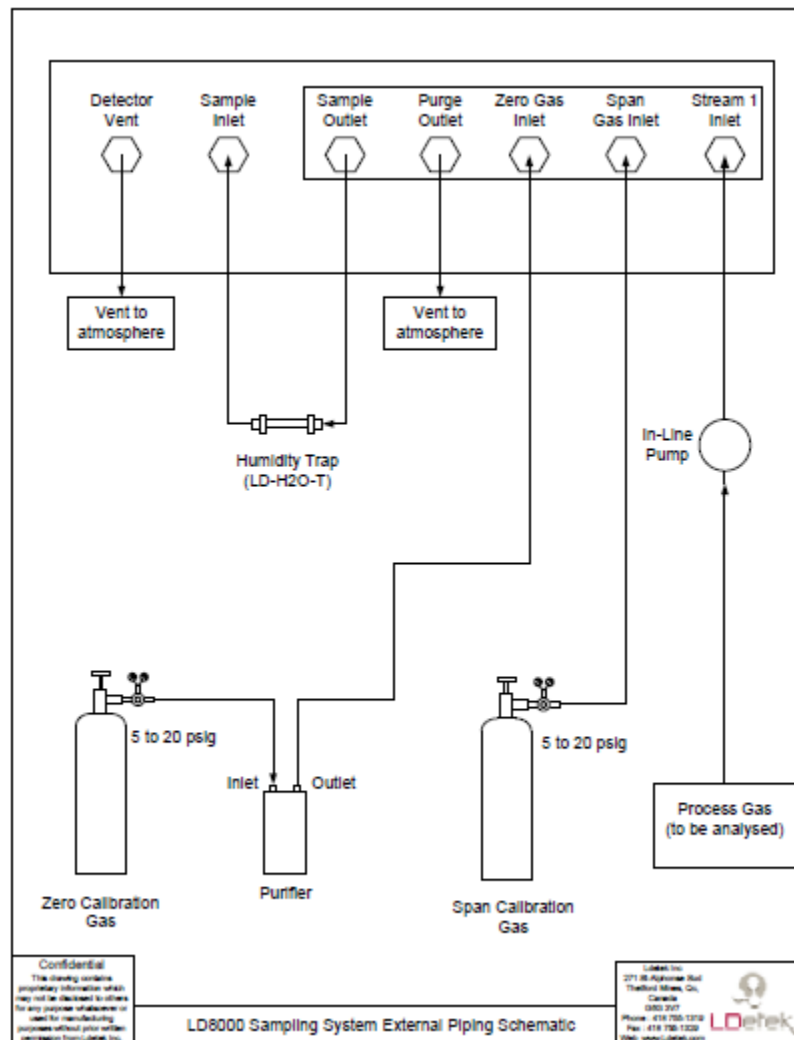

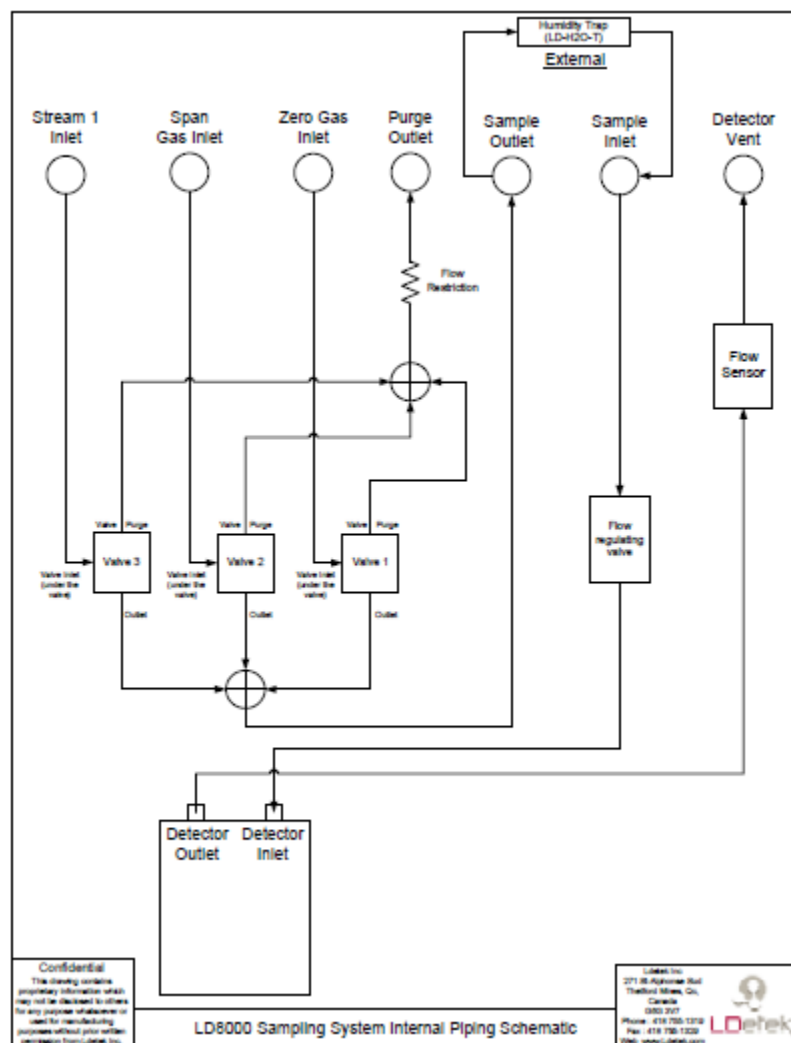

The auto calibration option can also be added to the integrated stream selector system. It consists of having the software interface that gives the benefit to configure an automatic routine for the analyzer calibration. Please refer to the calibration menu snapshot below for further details.

Calibration menu:

When the client chose the option of integrating sampling system the calibration menu appears as below.



- Calib N2 : Will calibrate give access to Zero and Span calibration of N2 measurement
- Calib O2 : Will calibrate give access to Zero and Span calibration of O2 measurement
- Calib H2O : Will calibrate give access to Zero and Span calibration of H2O measurement
- Calib CnHm : Will calibrate give access to Zero and Span calibration of CnHm measurement
- Sample Stream : Will activated the Sample stream.
- Span1 Stream : Will activated the span1 stream.
- Span2 Stream : Will activated the span2 stream.
- Span3 Stream : Will activated the Span3 stream. (only appear if they have 4 samples, only possible if no Zero gas free option)
- Span4 Stream : Will activated the Span3 stream. (only appear if they have 5 samples, only possible if no Zero gas free option)

When the user selects one stream, a message will indicate which stream is activated in third page of Real Time Menu.

11.3 Zero gas free system

The zero gas free system is used for generating a zero reference gas which is necessary for the zero calibration of the LD8000 Multigas. The integrated zero gas generator modules are combined with the high purity selection valves that make this system ideal to generate a good zero calibration.

In many cases, the zero calibration is not considered serious and it's resulted in giving negative reading on the process gas, since the process gas can be better quality than the zero gas that was used for calibration. Using LD8000 Multigas zero gas free system, the process gas (sample gas) is purified to get high purity argon or helium for generating a good zero calibration. Furthermore, no need of external gas purifier or traps system is required for purifying the zero gas sources.

The whole system is integrated in the LD8000 Multigas and is fully monitored and controlled by the interface. Most of the operations are compatible with a standard LD8000 Multigas. The differences that are unique to the zero gas free system are listed in this 10.3 Zero gas free system section.

Specifications:

The operating sample inlet pressure of the LD8000 Multigas with the integrated zero gas free system must operate at a minimum pressure of 5 PSIG. The maximum acceptable inlet pressure is 30 PSIG. LDetek can't guarantee the performances of the unit if the sample inlet pressure isn't in the requested range of operation. The unit can be damaged if the inlet pressure goes over 30 PSIG.

Calibration menu:

For running a zero calibration. Go in calibration menu and press 1,2,3 or 4 to select the gas you want to calibrate. After that, press 1 to rezero the impurity you just selected. The valves are then set automatically in the position to allow the sample gas (that was already selected before to start Zero calibration) going through the integrated zero gas generator module to purify the sample gas. After pressing 1(Re-Zero) button, a screen will appear showing the temperature of the internal gas purifier and we have to wait until its temperature is ok. After that a purging time countdown message will appear. You have to wait this countdown to finish and ideally watch the reading in ppm of the impurity you are calibrating for stability before to push the "E" button to "Accept" the zero calibration. Waiting for system stabilization before to accept the zero calibration is required. LDetek usually suggest waiting in between 3 to 5 minutes to allow system stabilization prior to zero calibration.

To ensure the good performances of the system, it is important to keep the operating sample flow rate and the zero calibration sample flow rate with the factory settings.

Zero gas free system components:

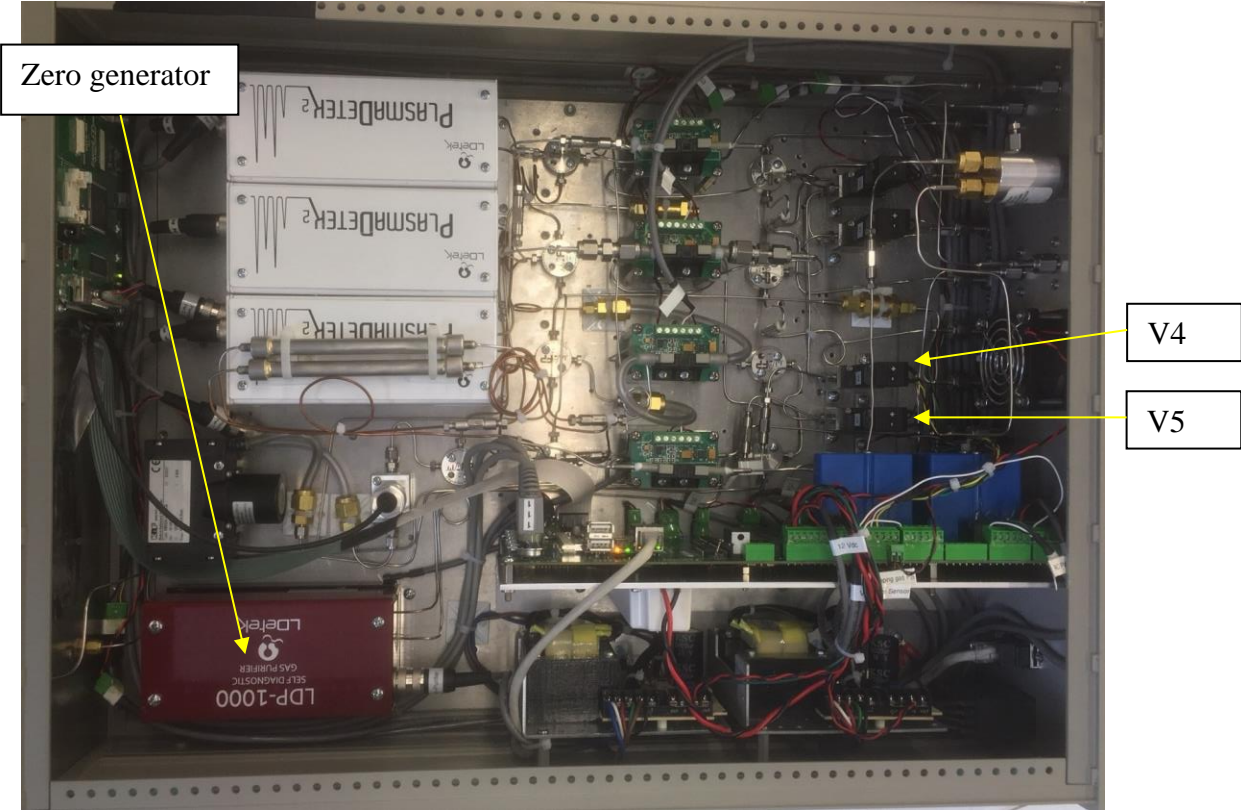

Zero gas free flow path diagram:

Sample gas position: The valve 4 & valve 5 are set at off position to allow sample gas going directly to the plasmas. This is the normal operation mode for sample gas analysis.

Zero gas position: The valve 4 & valve 5 are set at on position to allow sample gas going in the zero generator and then go to the plasmas. This is a zero calibration operation mode.

Span gas position: The valve 4 & valve 5 are set at off position to allow span gas going directly to the plasmas. This is the span calibration operation mode.

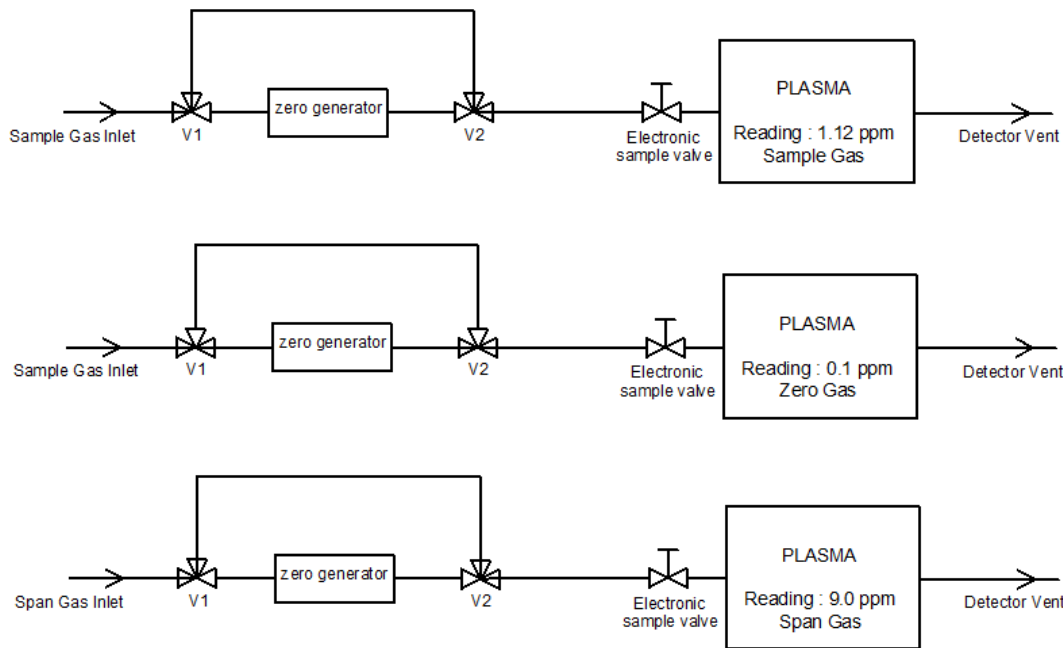

Important note



The integrated zero gas generator can be damaged if bad purging of the sample line prior to the sample inlet occurs. It is mandatory to keep gas flow rate as configured by LDetek factory through the LD8000 Multigas in all time. LDetek isn't responsible of damaged or bad functions of the zero gas free option if factory settings have been changed without advice to LDetek or if bad purging of the instrument has occurred. If the zero reference cell counts can't be reaching, it could be caused by contamination of the zero gas generator. In this case, contact LDetek factory.

The zero gas generator is consumable. It is then suggested to keep some parts in inventory for replacement.

11.4 Low pressure pump

If the sample point pressure is lower than 3 psig, it is required to install our metal bellow compressor to increase the sample pressure in the working range of the LD8000 Multigas which is between 5 PSIG to 30 PSIG. The pump type is high purity and allows measurement of low ppb nitrogen. It is fully tested at LDetek facility.

- The pump must be mounted external of the LD8000 Multigas and mounted on rubber standoff to reduce vibration of it.
- The pump must be connected to an external power source on 110VAC 50/60HZ or 220VAC50/60HZ depending of the requested pump model.
- The connections on the inlet and outlet of the pump are 1/8" inches Stainless Steel Swagelok compression type.
- The electrical connections to respect are indicated on the pump itself. Please refer to it. For the 220VAC version, refer to the image below for electrical connections.
- It is very important to install the included 1/8" inches OD, 10micron particle filters in the inlet fitting. This filter will block the particles coming up front the pump. Not installing the particle filter may result in damaging the pump.
- Outlet port relief valve setting should be 10 psig. Having higher outlet pressure will result of damaging the thin metal bellow. Increasing flow rate in the LD8000 is an alternative to the used of a relief valve to maintain the outlet pressure below 10 psig.

Electrical connections for 220VAC version

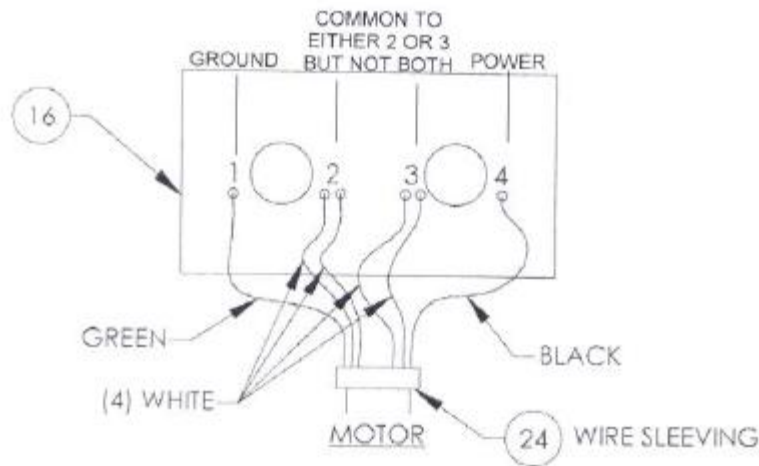

WIRING DIAGRAM
FIGURE 3

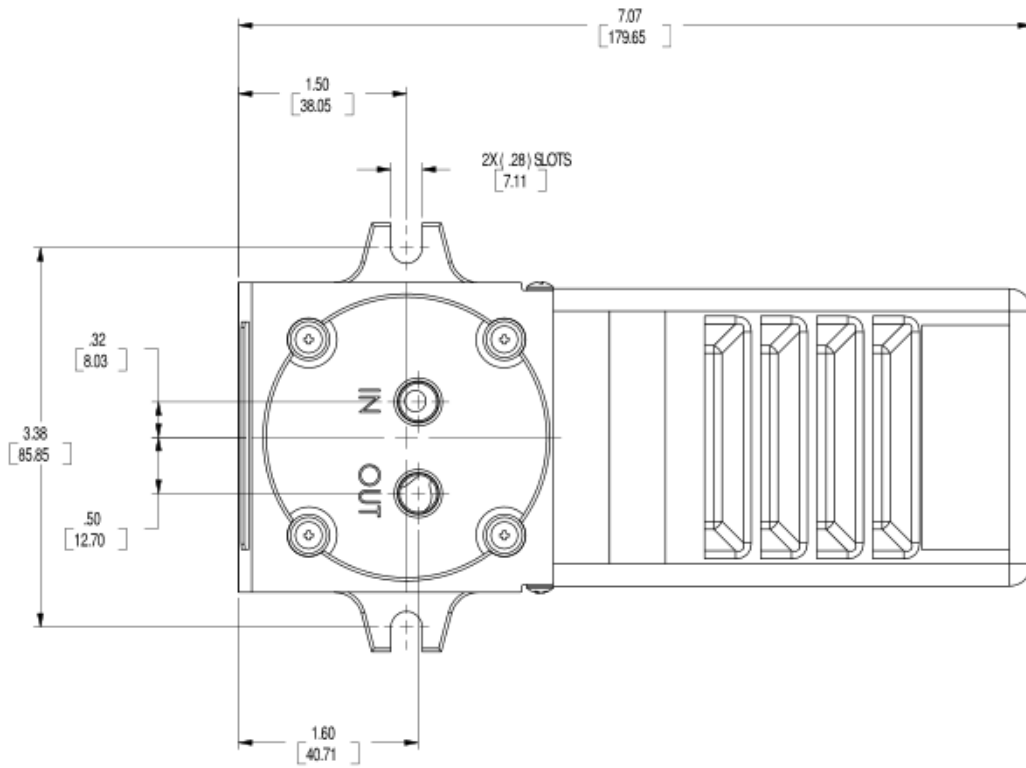
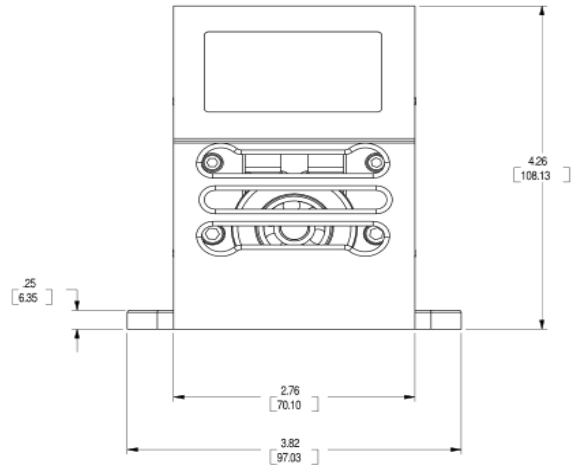

11.5 O2 and N2 dual measurement (3U cabinet)

O2 and N2 dual measurement system components:

The LD8000 series can offer dual trace O₂ and N₂ measurement in Argon/Helium. An electrochemical sensor is used for trace oxygen and the plasma is used for the trace nitrogen measurement. Both sensors have an individual electronic flow controller with minimal dead volume to ensure fast response time. The unit also offers an optional bypass flowmeter with adjustable valve from the back panel. This bypass flow meter is used to purge the gas line before the instrument up to a maximum of 0.5l/min. It is important to keep a minimum flow of 0.1l/min to ensure there is no dead volume stuck in the flow path. An optional integrated stream selector for 5 streams can be mounted in the same unit. This stream selector is used for switching from different streams to the span calibration gas. The flow consumption for the nitrogen plasma is maintained with the proportional valve in the range of 25-150sccm and the flow for the oxygen sensor is maintained in the range of 100-150sccm to ensure good performances of the sensors.

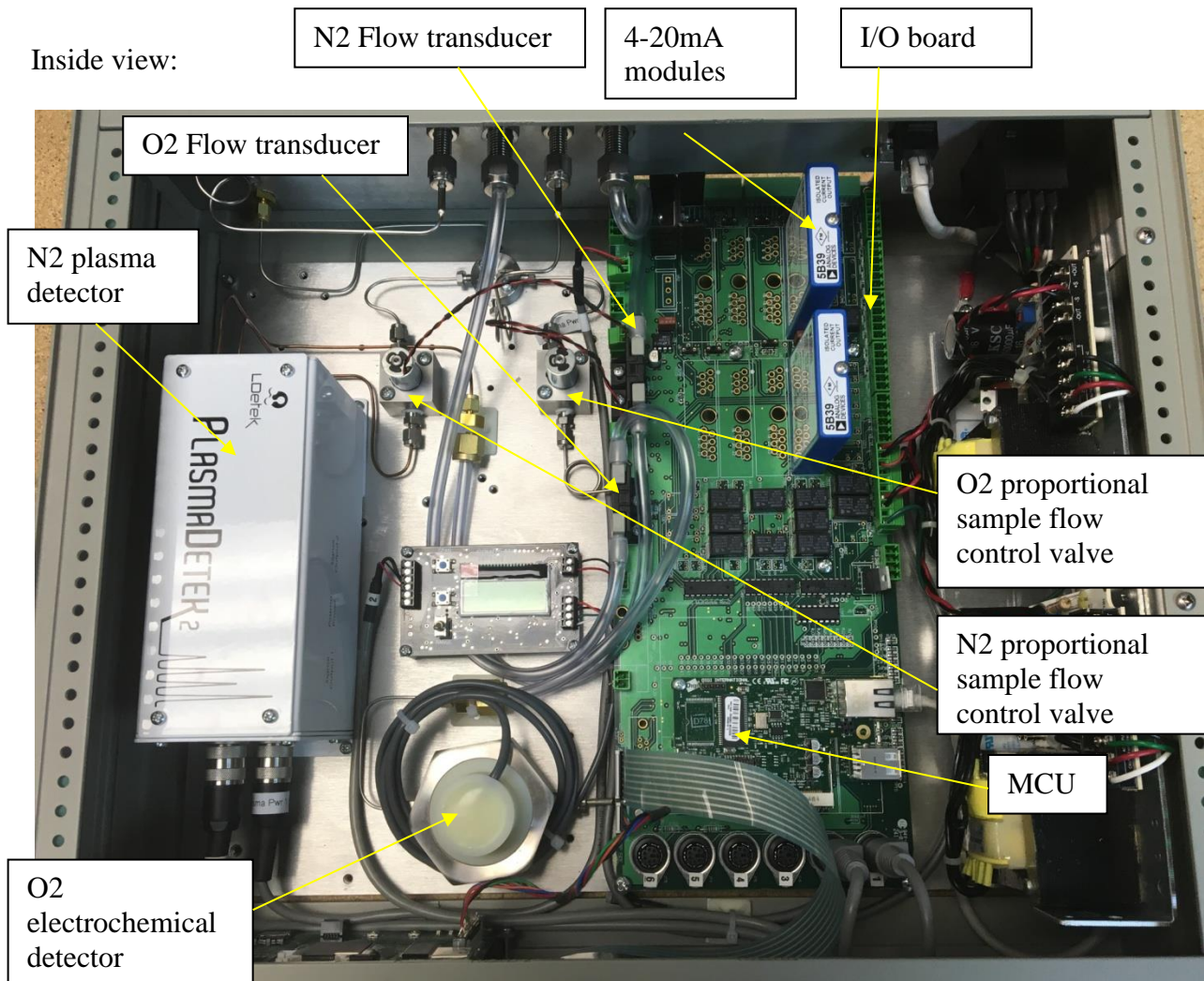

Backpanel view:

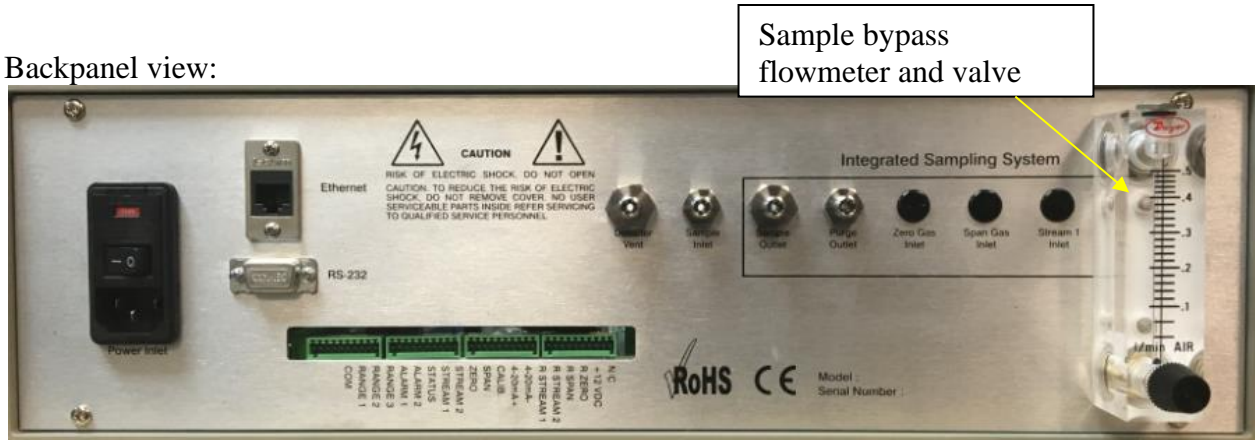

O2 and N2 dual measurement system internal piping diagram:

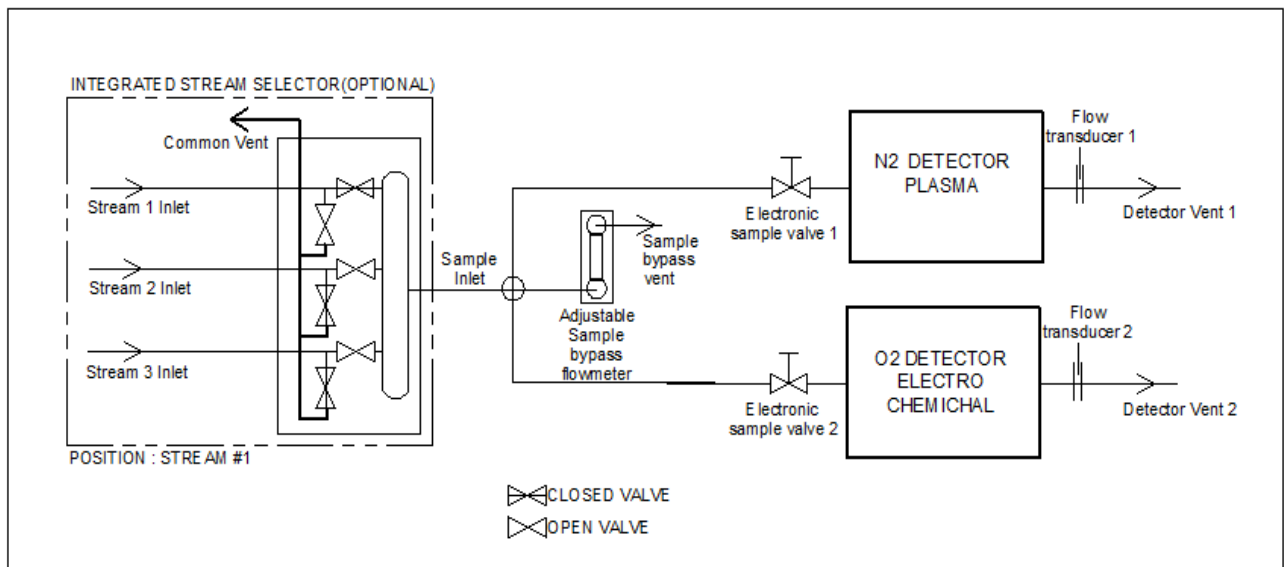

12. Ordering Information and spare parts

LD8000MG	-XXXX	-XXX	-X	-XX	-X	-XXX
	PEDN2: N2 by PED PEDO2: O2 by PED PEDH2O: H2O by PED PEDCnHm: HC's by PED ECO2: O2 by Electrochemical ZRO2: O2 by Zirconia DPH2O: H2O by ceramic sensor QMAH2O: H2O by quartz crista	Operating Voltage 120: 120 Volts 220: 220 Volts	A: Alarm Option	Integrated sampling system S1: 1 Stream + zero + span S2: 2 Streams + zero + span	C: Zero gas free system	Serial communication RS2: RS-232 RS4: RS-485 PFB: Profibus

13.Maintenance

Referring to the spare part list: the manufacturer item numbers, the descriptions, the replacement frequencies as well as the associated procedure numbers are identified.

13.1 Spare part list

Contact LDetek service department with reference to the serial number of your instrument : support@ldetek.com and they will send you the spare part list referring to your instrument

13.2 Frequently asked questions

Problems	Solutions (by priority)
Low Flow 1 Low Flow 2 Low Flow 3 Low Flow 4	<ol style="list-style-type: none"> 1. Check if the setpoint value is correct referring to the operating parameter sheet. 2. Check if sample gas pressure is correct referring to the operating parameter sheet. 3. Try to bypass the gas purifier or any gas filter that could restricts the sample inlet gas. 4. Measure flows at sample outlet(s) and note them. 5. Contact LDetek technical service by giving the results obtained with the previous steps.
Low Flow N2	<ol style="list-style-type: none"> 1. Check if sample N2 gas pressure is correct referring to the operating parameter sheet. 2. Try to bypass the gas purifier or any gas filter that could restricts the sample inlet gas. 3. Measure flows at sample outlet(s) and note them. 4. Check if the Manual pressure regulator is well adjusted. 5. Contact LDetek technical service by giving the results obtained with the previous steps.
High Flow N2	<ol style="list-style-type: none"> 1. Check if sample N2 gas pressure is correct referring to the operating parameter sheet. 2. Check if the Manual pressure regulator is well adjusted. 3. Contact LDetek technical service by giving the results obtained with the previous steps.
N2 Treshold Exceed	<ol style="list-style-type: none"> 1. Check if sample gas should contains more Nitrogen than the N2 treshold setting. If yes, This alarm is normal. 2. Install another sample gas that could contains less N2. 3. Check for leaks on sample gas line.

	<ol style="list-style-type: none"> 4. Check for N2 calibration. Re-calibrate zero and Span calibration of N2 impurity. Refer to calibration procedure section of this manual 7.2. 5. Contact LDetek technical service by giving the results obtained with the previous steps.
Detector off alarm	<ol style="list-style-type: none"> 1. Check the raw signals and compare them to the operating parameter sheet. Refer to Real time menu section of this manual 7.1. 2. Check the Starting count value in Administration menu. Refer to Administration menu section of this manual 7.6. 3. Contact LDetek technical service by giving the results obtained with the previous steps.
Vaccum P.Deviation	<ol style="list-style-type: none"> 1. Check the A.Press. value shown by the analyser (Refer to Real Time menu of this manual 2.1) and compare this value to the A.Pressure value on the Operation parameters sheet. 2. Can you hear the gas pump turn inside the analyser. 3. Check if sample flows and N2 flow reading are exact to the operating parameter sheet. 4. Contact LDetek technical service by giving the results obtained with the previous steps.
Range Overscale N2 Range Overscale O2 Range Overscale H2O Range Overscale cnhm	<ol style="list-style-type: none"> 1. Check if sample gas should contains more N2 or/and O2 or/and H2O or/and Cnhm than the N2/O2/H2O/Cnhm Scale setting(s). If yes, This alarm is normal. 2. Install another sample gas that could contains less of this or these impurities. 3. Check for leaks, oil or water on/in sample gas line. 4. Check for N2/O2/H2O/Cnhm calibration. Re-calibrate zero and Span calibration of the impurity(ies). Refer to calibration procedure section of this manual 7.2. 5. Contact LDetek technical service by giving the results obtained with the previous steps.
High Cnhm level	<ol style="list-style-type: none"> 1. Check if sample gas should contain more Cnhm than High Cnhm threshold setting. If yes, This alarm is normal. 2. Install another sample gas that could contains less of this impurity. 3. Check for oil presence in sample gas line. 4. Check for Cnhm calibration. Re-calibrate zero and Span calibration of the impurity. Refer to calibration procedure section of this manual 7.2. 5. Contact LDetek technical service by giving the results obtained with the previous steps.
Display off	<ol style="list-style-type: none"> 1. Press "Enter" Button on front panel of the instrument. The analyser has a "Screen saver" mode that deactivate and activate screen by pressing enter in the main menu. 2. Check if the Main power switch is ON at back of the instrument.

	<ol style="list-style-type: none"> 3. If the previous points are all correct, try to restart the analyser by switching the main switch Off and On. 6. Check the Fuses in the Power Entry Module. Refer to Back panel identification section of this manual 8.3. 4. Contact LDetek technical service by giving the results obtained with the previous steps.
4-20mA output defective	<ol style="list-style-type: none"> 1. Recalibrate the defective output according to the section 9.1 of this manual. Analog output calibration procedure. 2. Refer to drawing "Motherboard and MCU" of the drawing section 6.2 for identifying the 4-20mA modules and fuses. Check if the fuse is not blown for the defective output. Remove the fuse to check it and measure the continuity of it. Refer to the spare part list to order the appropriate fuse. 3. Swap the defective 4-20mA module with a known working module and test it. Refer to the spare part list to order the appropriate module. 4. Contact LDetek technical service by giving the results obtained with the previous steps.
Unstable reading	<ol style="list-style-type: none"> 1. Be sure there is no active alarm. If there are alarms, they must be resolved. 2. Be sure the calibration has been properly done. 3. Provide the followings information to a LDetek specialist and they will guide you to the next step : <ol style="list-style-type: none"> a) S/N of the unit b) Certified gas calibration values of the span cylinder(s) and its balance gas c) Quality of the sample gas analysed d) All detectors counts of the last zero calibration e) All detectors Counts of the last span calibration

Thank you for using LDetek Products



LDetek

Where **innovation** leads to **success**