

SO2-AF Sulfur Dioxide Sensor

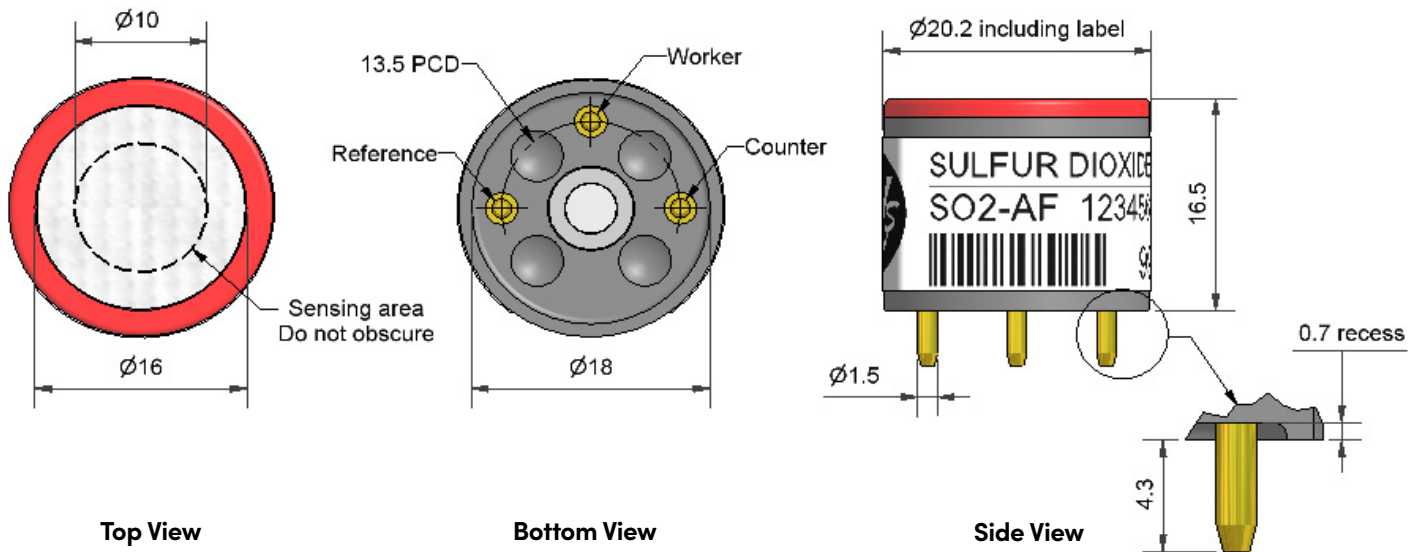

Dimensions are in millimetres (± 0.1 mm).

Performance	Sensitivity	nA/ppm in 10ppm SO ₂	300 to 550
	Response time	t ₉₀ (s) from zero to 10ppm SO ₂	< 35
	Zero current	ppm equivalent in zero air	< ± 0.6
	Resolution	RMS noise (ppm equivalent)	< 0.1
	Range	ppm limit of performance warranty	50
	Linearity	ppm error at full scale, linear at zero and 10ppm	< ± 0.3
	Overgas limit	maximum ppm for stable response to gas pulse	75
Lifetime	Zero drift	ppm equivalent change/year in lab air	< 0.1
	Sensitivity drift	% change/year in lab air, monthly test	< 4
	Operating life	months until 80% original signal (24 month warranted)	> 24
Environmental	Sensitivity @ -20°C	% (output @ -20°C/output @ 20°C) @ 10ppm	70 to 90
	Sensitivity @ 50°C	% (output @ 50°C/output @ 20°C) @ 10ppm	90 to 102
	Zero @ -20°C	ppm equivalent change from 20°C	< ± 0.8
	Zero @ 50°C	ppm equivalent change from 20°C	< ± 3
Cross sensitivity	Filter capacity	ppm-hrs H ₂ S	1000
	H ₂ S sensitivity	% measured gas @ 20ppm H ₂ S	< 3
	NO ₂ sensitivity	% measured gas @ 10ppm NO ₂	< -130
	Cl ₂ sensitivity	% measured gas @ 10ppm Cl ₂	< -60
	NO sensitivity	% measured gas @ 50ppm NO	< ± 2
	CO sensitivity	% measured gas @ 400ppm CO	< 1.6
	H ₂ sensitivity	% measured gas @ 400ppm H ₂	< 0.3
	C ₂ H ₄ sensitivity	% measured gas @ 400ppm C ₂ H ₄	< 40
NH ₃ sensitivity	% measured gas @ 20ppm NH ₃	< 0.1	
Key specifications	Temperature range	°C	-30 to 50
	Pressure range	kPa	80 to 120
	Humidity range	% rh continuous	15 to 90
	Storage period	months @ 3 to 20°C (stored in sealed pot)	6
	Load resistor	Ω (recommended)	10 to 47
	Weight	g	< 6

Figure 1 Sensitivity Temperature Dependence

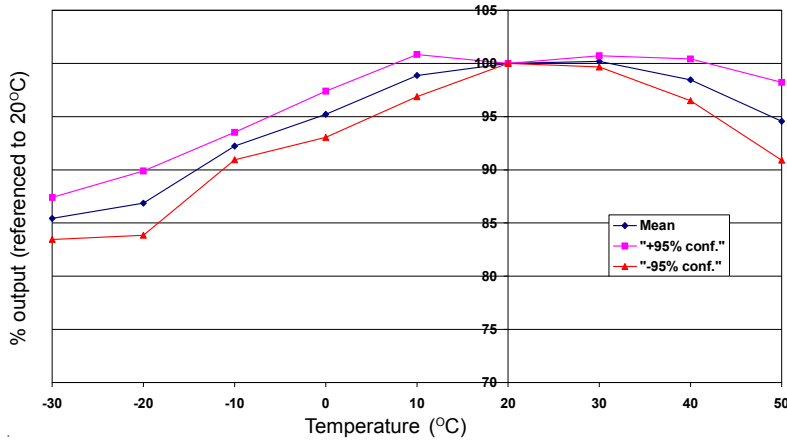

Figure 1 shows the variation in sensitivity caused by changes in temperature.

This data is taken from a typical batch of sensors. The mean and 95% confidence intervals are shown.

Figure 2 Zero Temperature Dependence

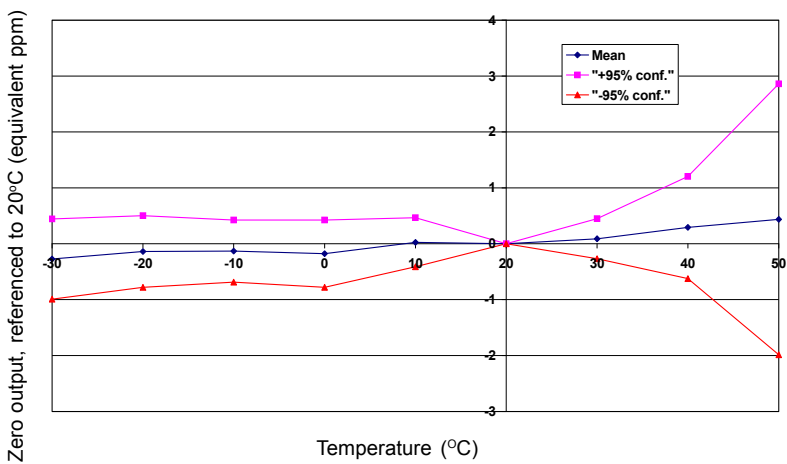
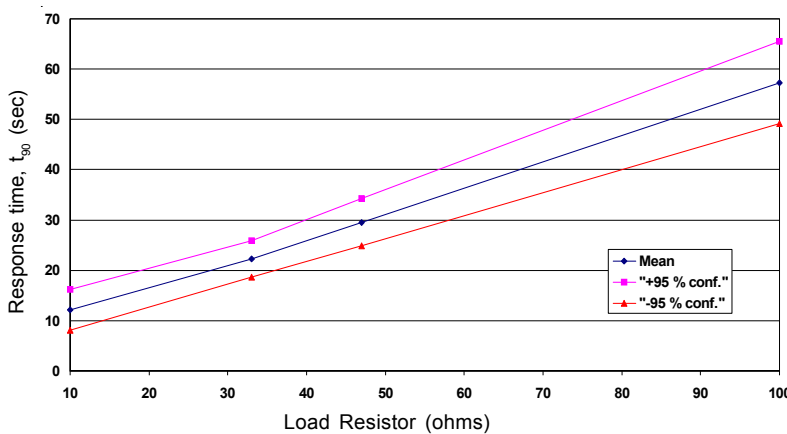

Figure 2 shows the variation in zero output caused by changes in temperature, expressed as ppm gas equivalent, referenced to zero at 20°C.

This data is taken from a typical batch of sensors.

Figure 3 Response Time vs. Load Resistor



As with all Alphasense toxic gas sensors, increasing the load resistor slows the response time, but also reduces noise for better resolution.

At the end of the product's life, do not dispose of any electronic sensor, component or instrument in the domestic waste, but contact the instrument manufacturer, Alphasense or its distributor for disposal instructions. NOTE: All sensors are tested at ambient environmental conditions, with 10 ohm load resistor, unless otherwise stated. As applications of use are outside our control, the information provided is given without legal responsibility. Customers should test under their own conditions, to ensure that the sensors are suitable for their own requirements.

In the interest of continued product improvement, we reserve the right to change design features and specifications without prior notification. The data contained in this document is for guidance only. Alphasense Ltd accepts no liability for any consequential losses, injury or damage resulting from the use of this document or the information contained within. (©ALPHASENSE LTD) Doc. Ref. SO2-AF/SEP22