

SO₂-AE Sulfur Dioxide Sensor – High Concentration

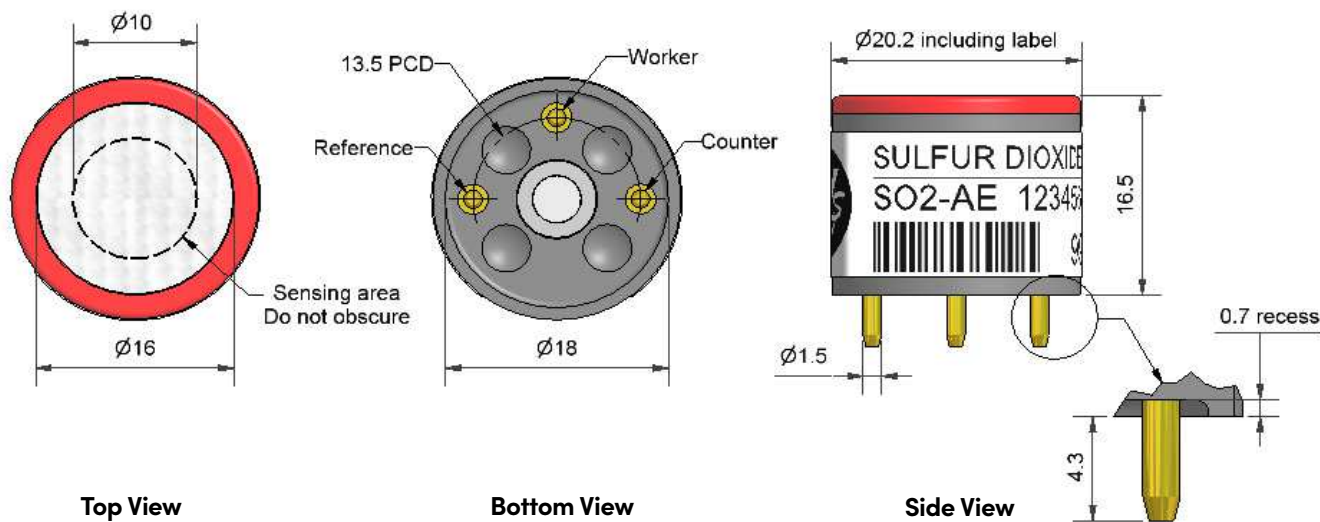

Dimensions are in millimetres (± 0.1 mm).

Performance			
Sensitivity	nA/ppm in 400ppm SO ₂		50 to 80
Response time	t90 (s) from zero to 400ppm SO ₂		< 33
Zero current	ppm equivalent in zero air		< ± 5
Resolution	RMS noise (ppm equivalent)		< 1.5
Range	ppm limit of performance warranty		2,000
Linearity	ppm error at full scale, linear at zero and 400ppm		+20 to -20
Overgas limit	maximum ppm for stable response to gas pulse		10,000

Lifetime			
Zero drift	ppm equivalent change/year in lab air		< 0.2
Sensitivity drift	% change/year in lab air, monthly test		< 4
Operating life	months until 80% original signal (24 month warranted)		> 24

Environmental			
Sensitivity @ -20°C	% (output @ -20°C/output @ 20°C) 400ppm		80 to 92
Sensitivity @ 50°C	% (output @ 50°C/output @ 20°C) 400ppm		98 to 108
Zero @ -20°C	ppm equivalent change from 20°C		< ± 3
Zero @ 50°C	ppm equivalent change from 20°C		< ± 4

Cross Sensitivity				
Filter capacity	ppm-hrs	H ₂ S		< 5,000
H ₂ S sensitivity	% measured gas @ 20ppm	H ₂ S		< 2
NO ₂ sensitivity	% measured gas @ 10ppm	NO ₂		< -150
Cl ₂ sensitivity	% measured gas @ 10ppm	Cl ₂		< -60
NO sensitivity	% measured gas @ 500ppm	NO		< 30
CO sensitivity	% measured gas @ 400ppm	CO		< 10
H ₂ sensitivity	% measured gas @ 400ppm	H ₂		< 1.5
C ₂ H ₄ sensitivity	% measured gas @ 1000ppm	C ₂ H ₄		< 60
NH ₃ sensitivity	% measured gas @ 20ppm	NH ₃		< 0.1

Key Specifications			
Temperature range	°C		-30 to 50
Pressure range	kPa		80 to 120
Humidity range	% rh continuous		15 to 90
Storage period	months @ 3 to 20°C (stored in sealed pot)		6
Load resistor	Ω (recommended)		10 to 47
Weight	g		< 6

Figure 1 Sensitivity Temperature Dependence

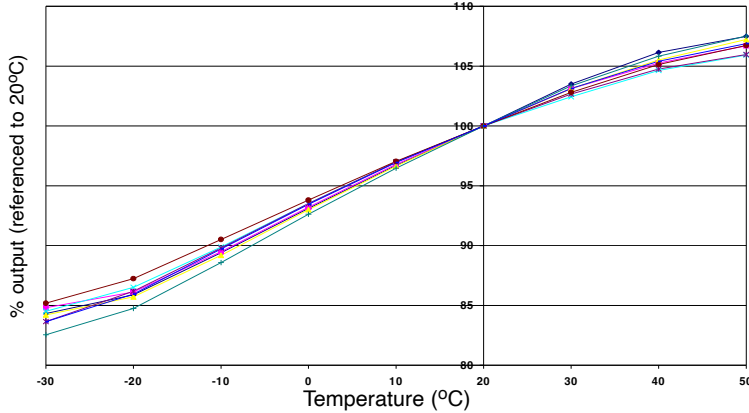

Figure 1 shows the variation in sensitivity caused by changes in temperature.

This data is taken from a typical batch of sensors.

Figure 2 Zero Temperature Dependence

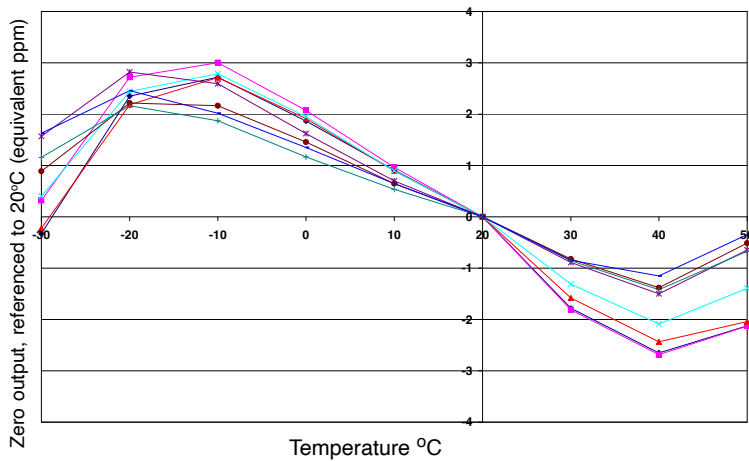

Figure 2 shows the variation in zero output caused by changes in temperature, expressed as ppm gas equivalent, referenced to zero at 20°C.

This data is taken from a typical batch of sensors.

Figure 3 Response to Step Changes up to 10,000 ppm SO₂

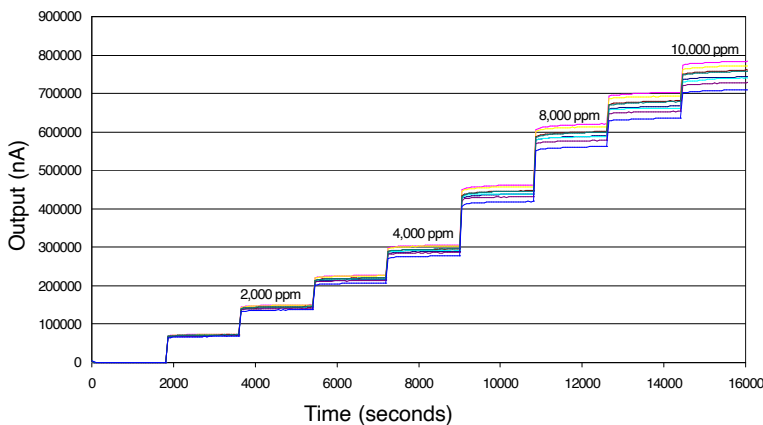

Figure 3 shows the response for a batch of sensors to high concentrations of SO₂ applied as sequential step increases.

The output remains linear over the range 0 to 10,000 ppm.

NOTE: All sensors are tested at ambient environmental conditions, with 10 ohm load resistor, unless otherwise stated. As applications of use are outside our control, the information provided is given without legal responsibility. Customers should test under their own conditions, to ensure that the sensors are suitable for their own requirements.

At the end of the product's life, do not dispose of any electronic sensor, component or instrument in the domestic waste, but contact the instrument manufacturer, Alphasense or its distributor for disposal instructions. NOTE: all sensors are tested at ambient environmental conditions unless otherwise stated. As applications of use are outside our control, the information provided is given without legal responsibility. Customers should test under their own conditions, to ensure that the sensors are suitable for their own requirements.

In the interest of continued product improvement, we reserve the right to change design features and specifications without prior notification. The data contained in this document is for guidance only. Alphasense Ltd accepts no liability for any consequential losses, injury or damage resulting from the use of this document or the information contained within. (©ALPHASENSE LTD) Doc. Ref. SO2-AE/SEP22