

PH3-B1 Phosphine Sensor

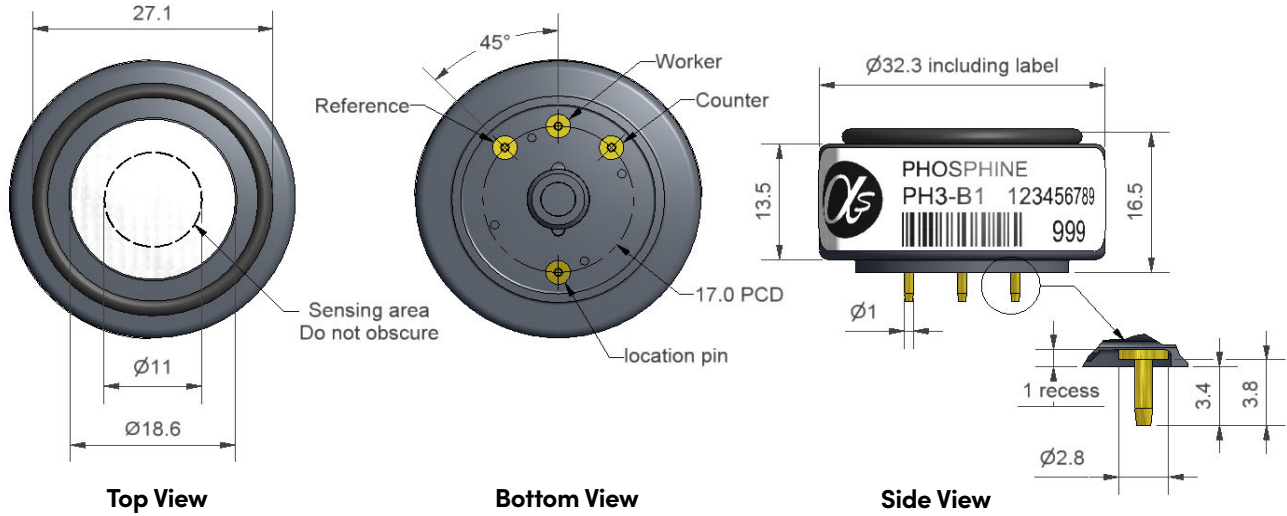

Dimensions are in millimetres (± 0.1 mm).

Performance	Sensitivity	nA/ppm in 5ppm PH ₃	600 to 1000
	Response time	t90 (s) from zero	< 20
	Zero current	ppm equivalent in zero air	< -0.3 to +0.3
	Resolution	RMS noise (ppm equivalent)	< 0.03
	Range	ppm limit of performance warranty	10
	Linearity	ppm PH ₃ error at full scale, linear at zero, 4ppm PH ₃	-1 to -1.8
	Overgas limit	maximum ppm for stable response to gas pulse	150
Lifetime	Zero drift	ppm equivalent change/year in lab air	< 0.05
	Sensitivity drift	% change/year in lab air, monthly test	< 4
	Operating life	months until 80% original signal (24-month warranted)	> 24
Environmental	Sensitivity @ -20°C	% (output @ -20°C/output @ 20°C) @ 5ppm PH ₃	65 to 85
	Sensitivity @ 50°C	% (output @ 50°C/output @ 20°C) @ 5ppm PH ₃	120 to 140
	Zero @ -20°C	ppm equivalent change from 20°C	< ± 0.5
	Zero @ 50°C	ppm equivalent change from 20°C	< 0 to +0.2
Cross Sensitivity	CO sensitivity	% measured gas @ 400ppm	CO < 1
	H ₂ S sensitivity	% measured gas @ 20ppm	H ₂ S < 170
	NO ₂ sensitivity	% measured gas @ 20ppm	NO ₂ < -30
	Cl ₂ sensitivity	% measured gas @ 10ppm	Cl ₂ < 0.1
	NO sensitivity	% measured gas @ 50ppm	NO < 30
	SO ₂ sensitivity	% measured gas @ 20ppm	SO ₂ < 30
	H ₂ sensitivity	% measured gas @ 400ppm	H ₂ at 20°C < 0.3
	C ₂ H ₄ sensitivity	% measured gas @ 400ppm	C ₂ H ₄ < 20
	NH ₃ sensitivity	% measured gas @ 20ppm	NH ₃ < 0.2
	CO ₂ sensitivity	% measured gas @ 5%	CO ₂ < 0.1
Key Specifications	Temperature range	°C	-30 to 50
	Pressure range	kPa	80 to 120
	Humidity range	% rh continuous	15 to 90
	Storage period	months @ 3 to 20°C (stored in sealed pot)	6
	Load resistor	Ω	10 to 33
	Weight	g	< 13

Figure 1 Sensitivity Temperature Dependence

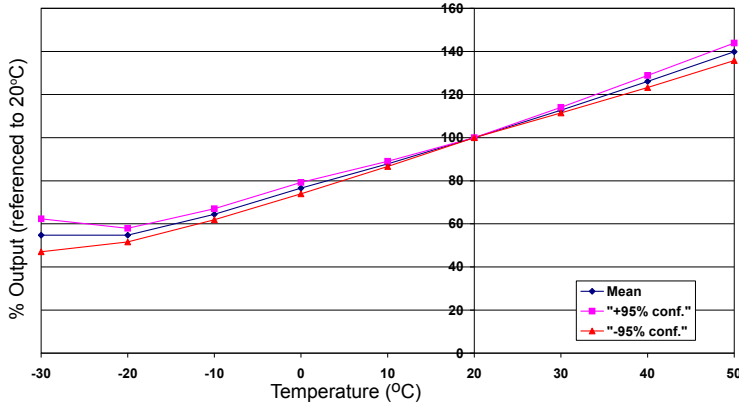

Figure 1 shows the variation in sensitivity caused by changes in temperature.

This data is taken from a typical batch of sensors. The mean and $\pm 95\%$ confidence intervals are shown.

Figure 2 Zero Temperature Dependence

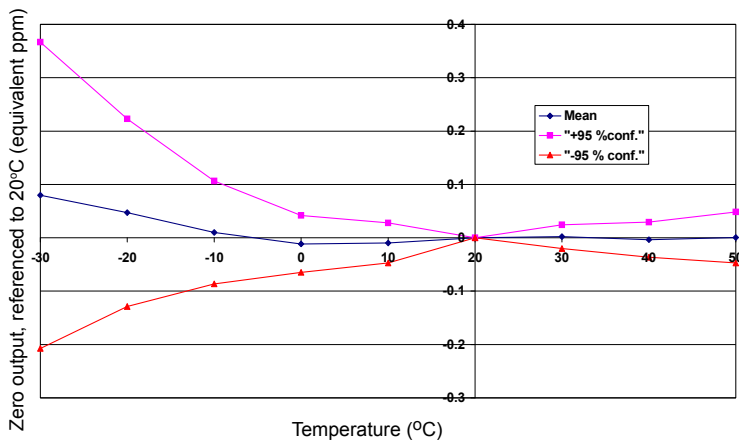
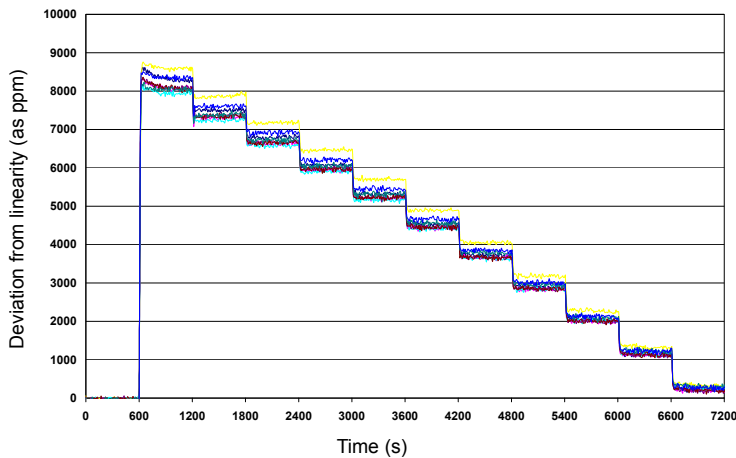

Figure 2 shows the variation in zero output caused by changes in temperature, expressed as ppm gas equivalent, referenced to zero at 20°C.

This data is taken from a typical batch of sensors. The mean and $\pm 95\%$ confidence intervals are shown.

Figure 3 Response from 10ppm PH3 to Zero



Eight PH3-B1 sensors were tested for response from 10 to 1ppm.

Fast response and stable readings are observed.

NOTE: All sensors are tested at ambient environmental conditions, with 10 ohm load resistor, unless otherwise stated. As applications of use are outside our control, the information provided is given without legal responsibility. Customers should test under their own conditions, to ensure that the sensors are suitable for their own requirements.

At the end of the product's life, do not dispose of any electronic sensor, component or instrument in the domestic waste, but contact the instrument manufacturer, Alphasense or its distributor for disposal instructions. NOTE: all sensors are tested at ambient environmental conditions unless otherwise stated. As applications of use are outside our control, the information provided is given without legal responsibility. Customers should test under their own conditions, to ensure that the sensors are suitable for their own requirements.

In the interest of continued product improvement, we reserve the right to change design features and specifications without prior notification. The data contained in this document is for guidance only. Alphasense Ltd accepts no liability for any consequential losses, injury or damage resulting from the use of this document or the information contained within. (©ALPHASENSE LTD) Doc. Ref. PH3-B1/SEP22