

NO₂-AE Nitrogen Dioxide Sensor

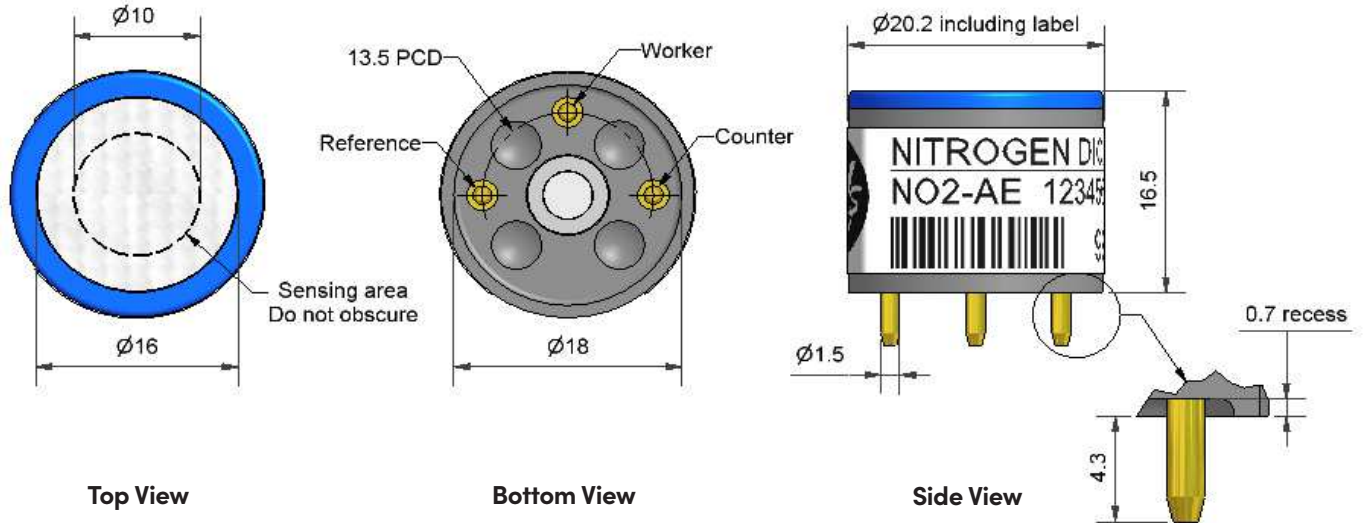

Dimensions are in millimetres (± 0.1 mm).

Performance			
Sensitivity	nA/ppm @ 20°C in 10ppm NO ₂ (33Ω Load Resistor)		-70 to -170
Response time	t90 (s) from zero to 10ppm NO ₂ (33Ω Load Resistor)		< 40
Zero current	ppm equivalent in zero air		< ± 1.5
Resolution	RMS noise (ppm equivalent) (33Ω)		< 0.1
Range	ppm limit of performance warranty		200
Linearity	ppm error at 200ppm, linear at 30 and 100ppm NO ₂		< 2 to 11
Overgas limit	maximum ppm for stable response to 10 minute gas pulse		> 1,000

Lifetime			
Zero drift	ppm equivalent change/year in lab air		nd
Sensitivity drift	% change/month in lab air, twice monthly gassing		< 2
Operating life	months until 80% original signal (24 month warranted)		> 24

Environmental			
Sensitivity @ -20°C	% (output @ -20°C/output @ 20°C) @ 10ppm NO ₂		75 to 95
Sensitivity @ 50°C	% (output @ 50°C/output @ 20°C) @ 10ppm NO ₂		98 to 110
Zero @ -20°C	ppm equivalent		< ± 0.5
Zero @ 50°C	ppm equivalent		< 0 to -5

Cross-sensitivity				
CO sensitivity	% measured gas @ 400ppm	CO		< 3.5
NO sensitivity	% measured gas @ 50ppm	NO		< 2
SO ₂ sensitivity	% measured gas @ 20ppm	SO ₂		< -30
Cl ₂ sensitivity	% measured gas @ 5ppm	Cl ₂		< 90
H ₂ sensitivity	% measured gas @ 400ppm	H ₂		< -0.8
H ₂ S sensitivity	% measured gas @ 200ppm	H ₂ S		< -220
C ₂ H ₄ sensitivity	% measured gas @ 400ppm	C ₂ H ₄		< 0.1
NH ₃ sensitivity	% measured gas @ 20ppm	NH ₃		< -1
CO ₂ sensitivity	% measured gas @ 5% volume	CO ₂		< 0
O ₃ sensitivity	% measured gas @ 100ppb	O ₃		< 120

Key Specifications			
Temperature range	°C		-20 to 50
Pressure range	kPa		80 to 120
Humidity range	% rh continuous		15 to 90
Storage period	months @ 3 to 20°C (stored in sealed pot)		6
Load resistor	Ω (for optimum performance)		33
Weight	g		< 6

Figure 1 Sensitivity Temperature Dependence

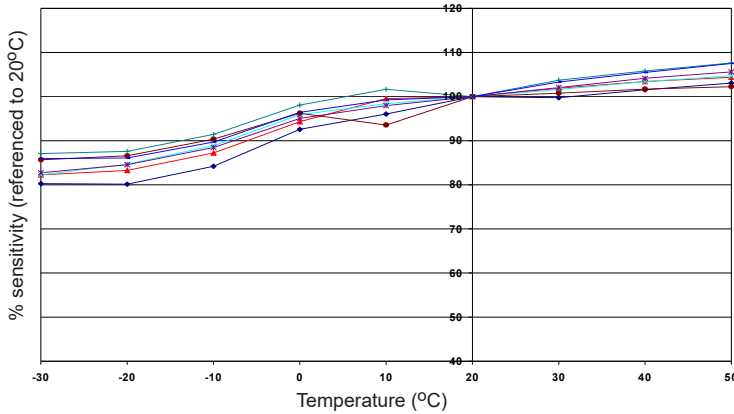

Figure 1 shows the variation in sensitivity caused by changes in temperature.

This data is taken from a typical batch of sensors.

Figure 2 Zero Temperature Dependence

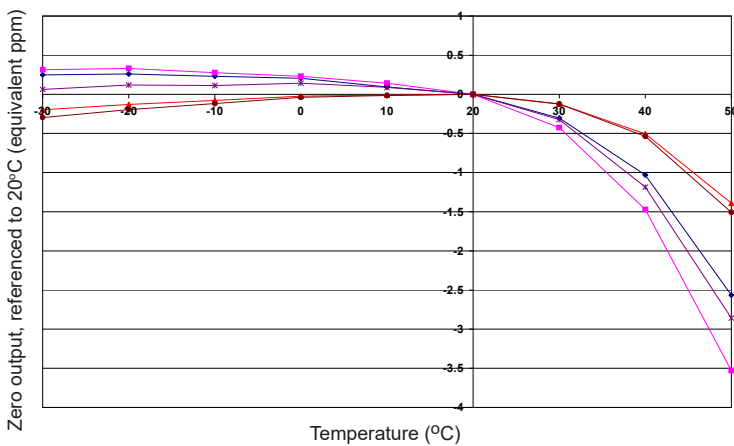

Figure 2 shows the variation in zero output caused by changes in temperature, expressed as ppm gas equivalent, referenced to zero at 20°C.

This data is taken from a typical batch of sensors.

Figure 3 Linearity to 200ppm NO₂

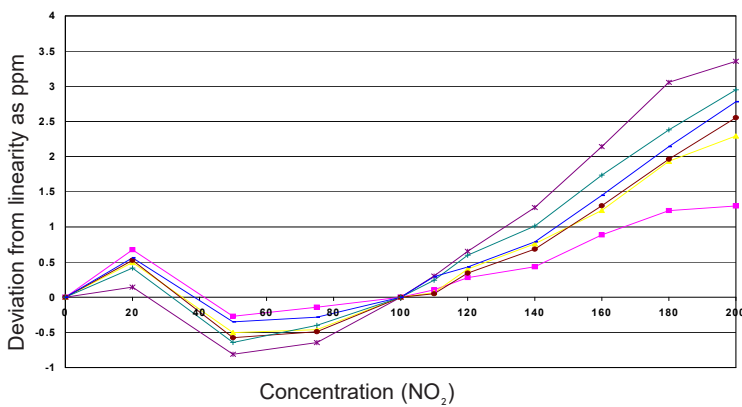

Figure 3 shows excellent and repeatable linearity to 200ppm NO₂ which allows this sensor to be used at high concentrations.

At the end of the product's life, do not dispose of any electronic sensor, component or instrument in the domestic waste, but contact the instrument manufacturer, Alphasense or its distributor for disposal instructions. NOTE: all sensors are tested at ambient environmental conditions unless otherwise stated. As applications of use are outside our control, the information provided is given without legal responsibility. Customers should test under their own conditions, to ensure that the sensors are suitable for their own requirements.

In the interest of continued product improvement, we reserve the right to change design features and specifications without prior notification. The data contained in this document is for guidance only. Alphasense Ltd accepts no liability for any consequential losses, injury or damage resulting from the use of this document or the information contained within. (©ALPHASENSE LTD) Doc. Ref. NO2-AE/SEP22