

## NO<sub>2</sub>-A1 Nitrogen Dioxide Sensor

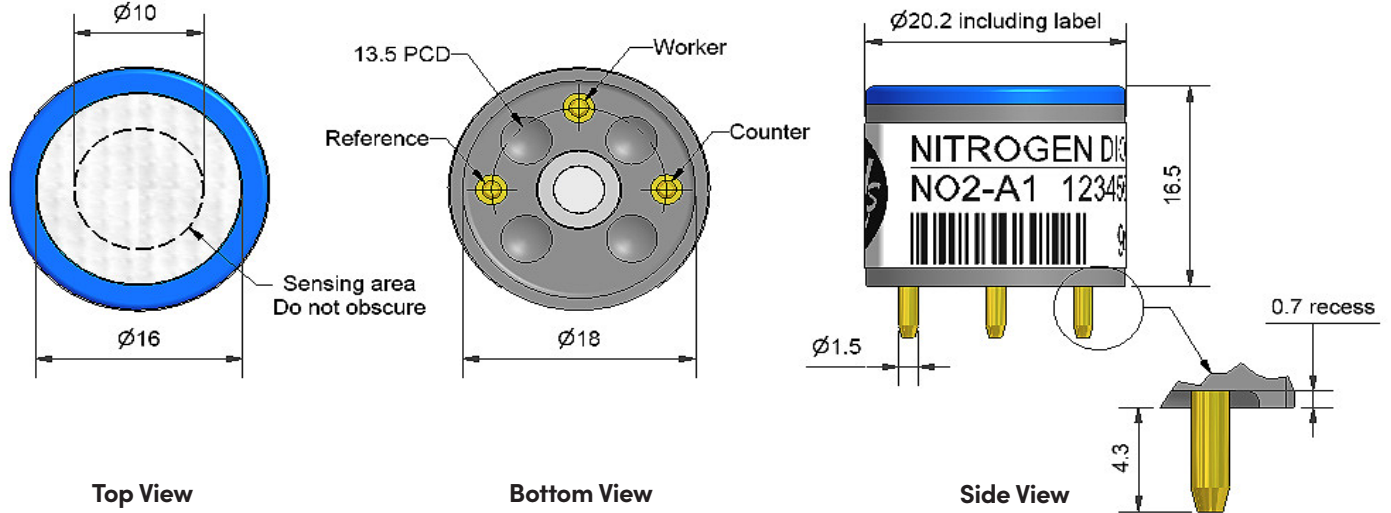

Dimensions are in millimetres ( $\pm 0.1$  mm).

<b>Performance</b>	Sensitivity	nA/ppm in 10ppm NO <sub>2</sub>	-250 to -650
	Response time	t90 (s) from zero to 10ppm NO <sub>2</sub> (33 $\Omega$ Load Resistor)	< 50
	Zero current	ppm equivalent in zero air	< $\pm 0.4$
	Resolution	RMS noise (ppm equivalent) (33 $\Omega$ Load Resistor)	< 0.02
	Range	ppm NO <sub>2</sub> limit of performance warranty	20
	Linearity	ppm error at full scale, linear at zero and 10ppm	< 1.5
	Overgas limit	NO <sub>2</sub> maximum ppm for stable response to gas pulse	100
<b>Lifetime</b>	Zero drift	ppm equivalent change/year in lab air	< 0.05
	Sensitivity drift	% change/year in lab air, monthly test	< -20 to -40
	Operating life	months until 80% original signal (24-month warranted)	> 24
<b>Environmental</b>	Sensitivity @ -20°C	% (output @ -20°C/output @ 20°C) @ 5ppm NO <sub>2</sub>	73 to 94
	Sensitivity @ 50°C	% (output @ 50°C/output @ 20°C) @ 5ppm NO <sub>2</sub>	105 to 125
	Zero @ -20°C	ppm equivalent change from 20°C	< $\pm 0.2$
	Zero @ 50°C	ppm equivalent change from 20°C	< 0 to -0.5
<b>Cross-sensitivity</b>	H <sub>2</sub> S sensitivity	% measured gas @ 20ppm	H <sub>2</sub> S < -35
	Cl <sub>2</sub> sensitivity	% measured gas @ 10ppm	Cl <sub>2</sub> < 80
	NO sensitivity	% measured gas @ 50ppm	NO < 5
	SO <sub>2</sub> sensitivity	% measured gas @ 20ppm	SO <sub>2</sub> < -15
	CO sensitivity	% measured gas @ 400ppm	CO < 0.1
	H <sub>2</sub> sensitivity	% measured gas @ 400ppm	H <sub>2</sub> < 0.1
	C <sub>2</sub> H <sub>4</sub> sensitivity	% measured gas @ 50ppm	C <sub>2</sub> H <sub>4</sub> < 0.1
	NH <sub>3</sub> sensitivity	% measured gas @ 20ppm	NH <sub>3</sub> < 0.1
	CO <sub>2</sub> sensitivity	% measured gas @ 5% volume	CO <sub>2</sub> < 0.1
	O <sub>3</sub> sensitivity	% measured gas @ 200ppb	O <sub>3</sub> < 120
<b>Key Specifications</b>	Temperature range	°C	-20 to 50
	Pressure range	kPa	80 to 120
	Humidity range	% rh continuous	15 to 90
	Storage period	months @ 3 to 20°C (stored in sealed pot)	6
	Load resistor	$\Omega$ (for optimum performance)	33
	Weight	g	< 6

**Figure 1 Sensitivity Temperature Dependence**

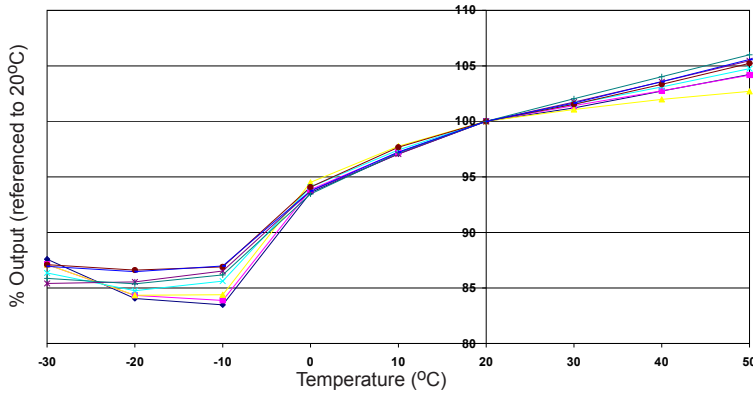

Figure 1 shows the variation in sensitivity caused by changes in temperature.

This data is taken from a typical batch of sensors.

**Figure 2 Zero Temperature Dependence**

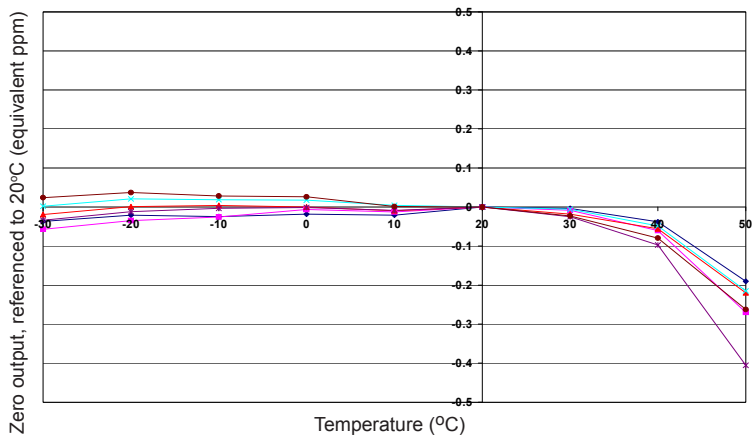

Figure 2 shows the variation in zero output caused by changes in temperature, expressed as ppm gas equivalent, referenced to zero at 20°C.

This data is taken from a typical batch of sensors.

**Figure 3 Humidity plus Temperature Transient Response**

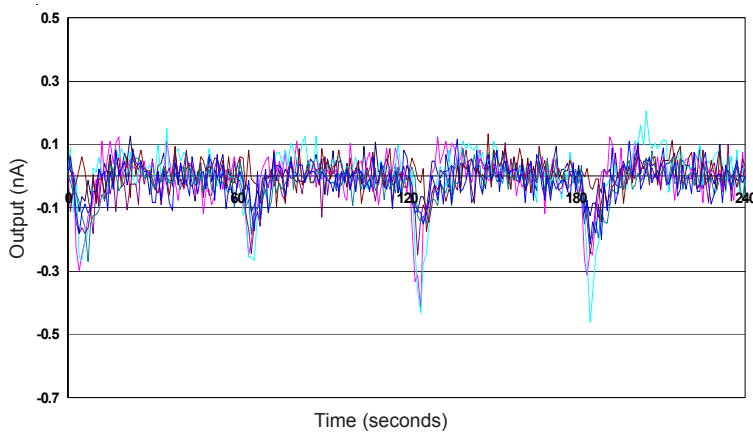

Figure 3 shows typical sensor outputs for a group of sensors exposed to exhaled breath for 4 cycles over 240 seconds.

This is an extreme test for such sensors and the shift in the base line of no more than 0.5 ppm shows a very strong resistance to this test.

At the end of the product's life, do not dispose of any electronic sensor, component or instrument in the domestic waste, but contact the instrument manufacturer, Alphasense or its distributor for disposal instructions. NOTE: all sensors are tested at ambient environmental conditions unless otherwise stated. As applications of use are outside our control, the information provided is given without legal responsibility. Customers should test under their own conditions, to ensure that the sensors are suitable for their own requirements.

In the interest of continued product improvement, we reserve the right to change design features and specifications without prior notification. The data contained in this document is for guidance only. Alphasense Ltd accepts no liability for any consequential losses, injury or damage resulting from the use of this document or the information contained within. (©ALPHASENSE LTD) Doc. Ref. NO2-A1/SEP22