

NO-B1 Nitric Oxide Sensor

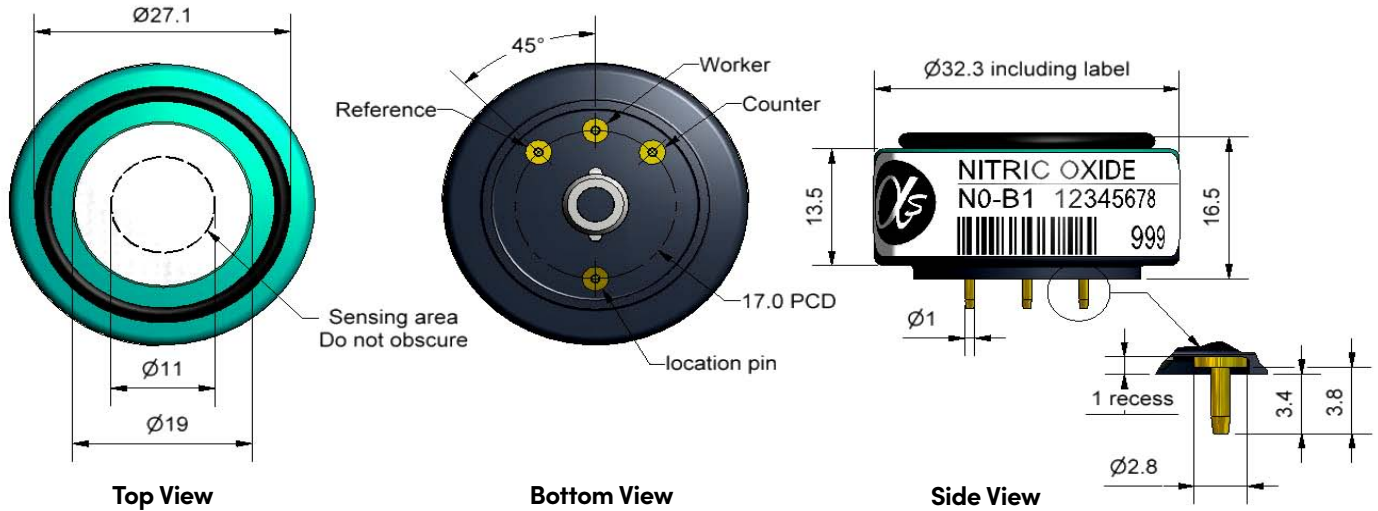

Dimensions are in millimetres (± 0.1 mm).

Performance	Parameter	Specification	Range
	Sensitivity	nA/ppm in 50ppm NO	400 to 620
	Response time	t90 (s) from zero to 50ppm NO	< 30
	Zero current	ppm equivalent in zero air	0 to +4
	Resolution	RMS noise (ppm equivalent)	< 0.15
	Range	ppm NO limit of performance warranty	250
	Linearity	ppm error at full scale, linear at zero and 50ppm NO	-20 to -25
	Overgas limit	maximum ppm for stable response to gas pulse	1,200

Lifetime	Parameter	Specification	Value
	Zero drift	ppm equivalent change/year in lab air	< 0.3
	Sensitivity drift	% change/year in lab air, monthly test	< 5
	Operating life	months until 80% original signal (24-month warranted)	> 24

Environmental	Parameter	Specification	Value
	Sensitivity @ -20°C	% (output @ -20°C /output @ 20°C) @ 50ppm NO	89 to 98
	Sensitivity @ 50°C	% (output @ 50°C /output @ 20°C) @ 50ppm NO	97 to 104
	Zero @ -20°C	ppm equivalent change from 20°C	< 0 to -2
	Zero @ 50°C	ppm equivalent change from 20°C	< 6 to 20

Cross Sensitivity	Gas	Sensitivity	Specification	Value
	H ₂ S	sensitivity	% measured gas @ 20ppm	< 60
	NO ₂	sensitivity	% measured gas @ 10ppm	< 5
	Cl ₂	sensitivity	% measured gas @ 10ppm	< 5
	SO ₂	sensitivity	% measured gas @ 20ppm	< 4
	H ₂	sensitivity	% measured gas @ 400ppm	< 0.1
	CO	sensitivity	% measured gas @ 400ppm	< 0.1
	NH ₃	sensitivity	% measured gas @ 20ppm	< 0.1
	CO ₂	sensitivity	% measured gas @ 5% volume	< 0.1

Key Specifications	Parameter	Specification	Value
	Bias voltage	mV (working electrode potential is above ground)	+300
	Temperature range	$^\circ\text{C}$	-30 to 50
	Pressure range	kPa	80 to 120
	Humidity range	% rh continuous	15 to 90
	Storage period	months @ 3 to 20°C (stored in sealed pot)	6
	Load resistor	Ω (recommended)	10 to 47
	Weight	g	< 13

Figure 1 Sensitivity Temperature Dependence

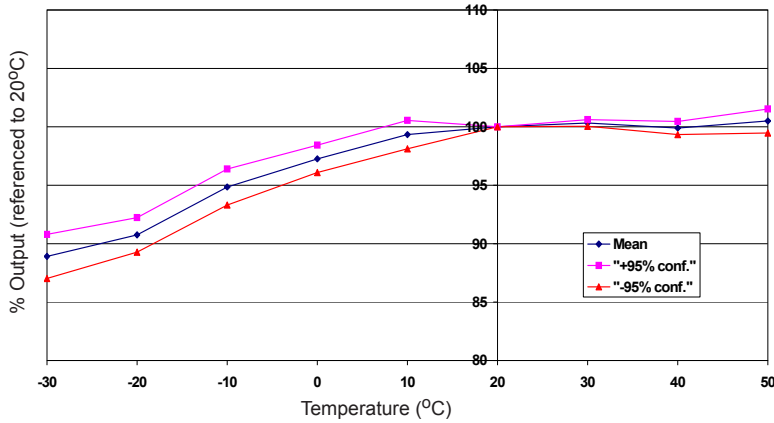

Figure 1 shows the variation in sensitivity caused by changes in temperature.

This data is taken from a typical batch of sensors. The mean and $\pm 95\%$ confidence intervals are shown.

Figure 2 Zero Temperature Dependence

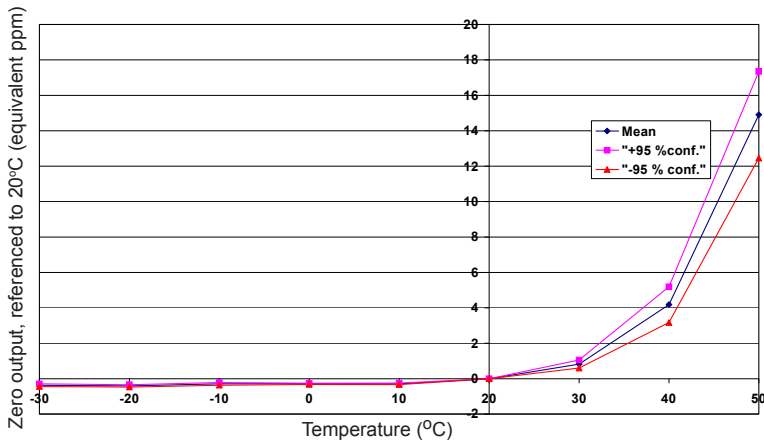
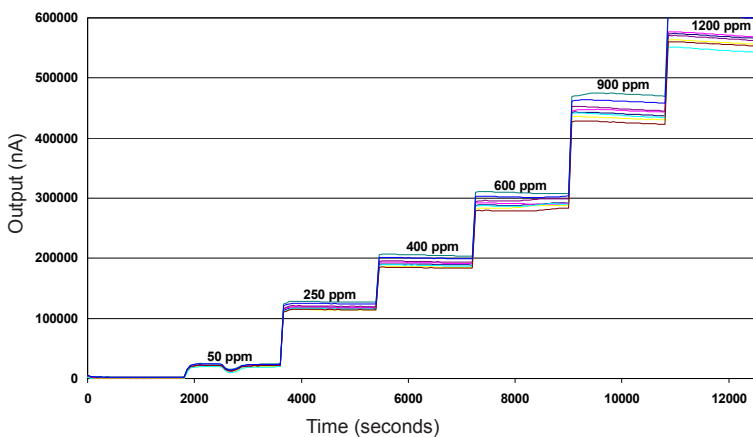

Figure 2 shows the variation in zero output caused by changes in temperature, expressed as ppm gas equivalent, referenced to zero at 20°C.

This data is taken from a typical batch of sensors. The mean and $\pm 95\%$ confidence intervals are shown.

Figure 3 NO-B1 Response to 1,200ppm NO



The NO-B1 responds rapidly to gas concentrations up to 1,200ppm NO.

This data is taken from a typical batch of sensors.

At the end of the product's life, do not dispose of any electronic sensor, component or instrument in the domestic waste, but contact the instrument manufacturer, Alphasense or its distributor for disposal instructions. NOTE: all sensors are tested at ambient environmental conditions unless otherwise stated. As applications of use are outside our control, the information provided is given without legal responsibility. Customers should test under their own conditions, to ensure that the sensors are suitable for their own requirements.

In the interest of continued product improvement, we reserve the right to change design features and specifications without prior notification. The data contained in this document is for guidance only. Alphasense Ltd accepts no liability for any consequential losses, injury or damage resulting from the use of this document or the information contained within. (©ALPHASENSE LTD) Doc. Ref. NO-B1/JUN22