

## HCN-B1 Hydrogen Cyanide Sensor

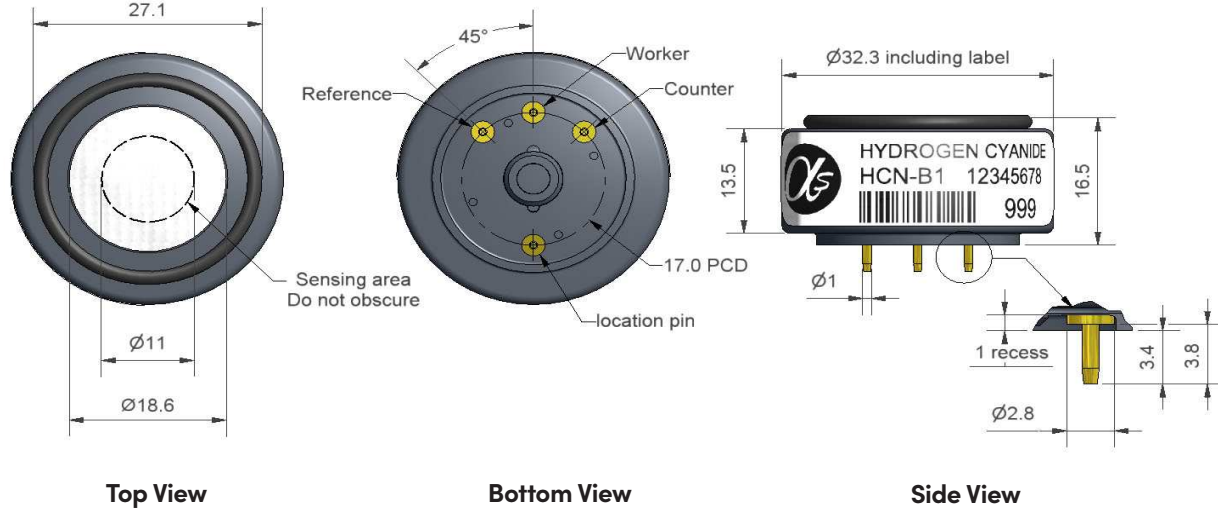

Dimensions are in millimetres ( $\pm 0.1$  mm).

<b>Performance</b>	Sensitivity	nA/ppm in 30ppm HCN	65 to 140
	Response time	t90 (s) from zero to 30ppm HCN	< 120
	Zero current	ppm equivalent in zero air	< -2.5 to 10
	Resolution	RMS noise (ppm equivalent)	< 0.05
	Range	ppm HCN limit of performance warranty	100
	Linearity	ppm error at full scale, linear at zero, 40ppm HCN	0 to 4
	Overgas limit	maximum ppm for stable response to gas pulse	200
<b>Lifetime</b>	Zero drift	ppm equivalent change/year in lab air	nd
	Sensitivity drift	% change/year in lab air, monthly test	nd
	Operating life	months until 80% original signal (12-month warranted)	> 12
<b>Environmental</b>	Sensitivity @ -10°C	% (output @ -10°C/output @ 20°C) @ 30ppm HCN	75 to 95
	Sensitivity @ 50°C	% (output @ 50°C/output @ 20°C) @ 30ppm HCN	100 to 115
	Zero @ -20°C	ppm equivalent change from 20°C	< 0 to -2
	Zero @ 50°C	ppm equivalent change from 20°C	< 0 to 2
<b>Cross-sensitivity</b>	H <sub>2</sub> S sensitivity	% measured gas @ 20ppm	H <sub>2</sub> S < 400
	NO <sub>2</sub> sensitivity	% measured gas @ 10ppm	NO <sub>2</sub> < -120
	Cl <sub>2</sub> sensitivity	% measured gas @ 10ppm	Cl <sub>2</sub> < 25
	NO sensitivity	% measured gas @ 50ppm	NO < 1
	SO <sub>2</sub> sensitivity	% measured gas @ 20ppm	SO <sub>2</sub> < 3 (transient)
	CO sensitivity	% measured gas @ 400ppm	CO < 0.1
	H <sub>2</sub> sensitivity	% measured gas @ 400ppm	H <sub>2</sub> < 0.1
	C <sub>2</sub> H <sub>4</sub> sensitivity	% measured gas @ 80ppm	C <sub>2</sub> H <sub>4</sub> < 0.1
	NH <sub>3</sub> sensitivity	% measured gas @ 20ppm	NH <sub>3</sub> < 2
	CO <sub>2</sub> sensitivity	% measured gas @ 5% volume	CO <sub>2</sub> < 0.1
<b>Key Specifications</b>	Temperature range	°C	-30 to 50
	Pressure range	kPa	80 to 120
	Humidity range	% rh continuous	15 to 90
	Storage period	months @ 3 to 20°C (stored in original container)	6
	Load resistor	Ω (recommended)	10 to 33
	Bias voltage	mV	not required
	Weight	g	< 6



**Figure 1 Sensitivity Temperature Dependence**

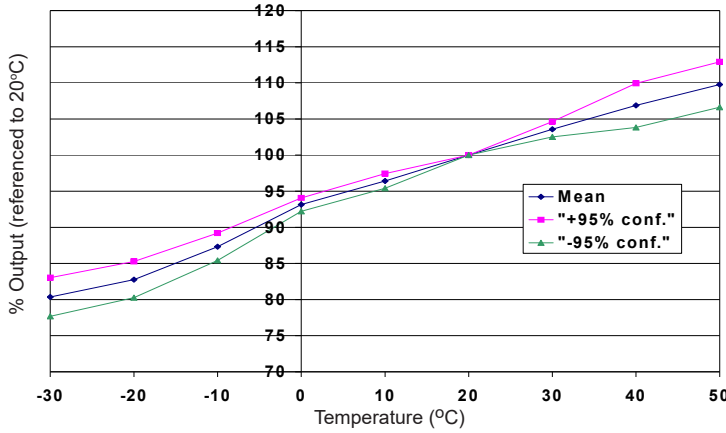

Figure 1 shows the variation in sensitivity caused by changes in temperature.

This data is taken from a typical batch of sensors. The mean and  $\pm 95\%$  confidence intervals are shown.

**Figure 2 Zero Temperature Dependence**

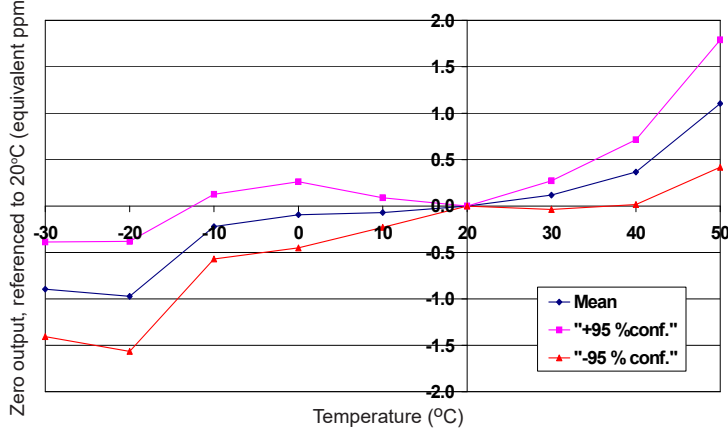
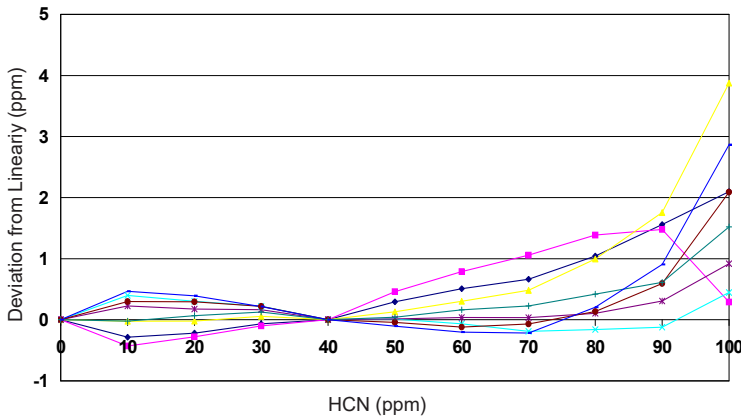

Figure 2 shows the variation in zero output caused by changes in temperature, expressed as ppm gas equivalent, referenced to zero at 20°C.

This data is taken from a typical batch of sensors. The mean and  $\pm 95\%$  confidence intervals are shown.

**Figure 3 Deviation from Linearity**



The HCN-B1 shows linear performance to 100ppm HCN.

At the end of the product's life, do not dispose of any electronic sensor, component or instrument in the domestic waste, but contact the instrument manufacturer, Alphasense or its distributor for disposal instructions. NOTE: all sensors are tested at ambient environmental conditions unless otherwise stated. As applications of use are outside our control, the information provided is given without legal responsibility. Customers should test under their own conditions, to ensure that the sensors are suitable for their own requirements.

In the interest of continued product improvement, we reserve the right to change design features and specifications without prior notification. The data contained in this document is for guidance only. Alphasense Ltd accepts no liability for any consequential losses, injury or damage resulting from the use of this document or the information contained within. (©ALPHASENSE LTD) Doc. Ref. HCN-B1/SEP22