

## HCL-A1 Hydrogen Chloride Sensor

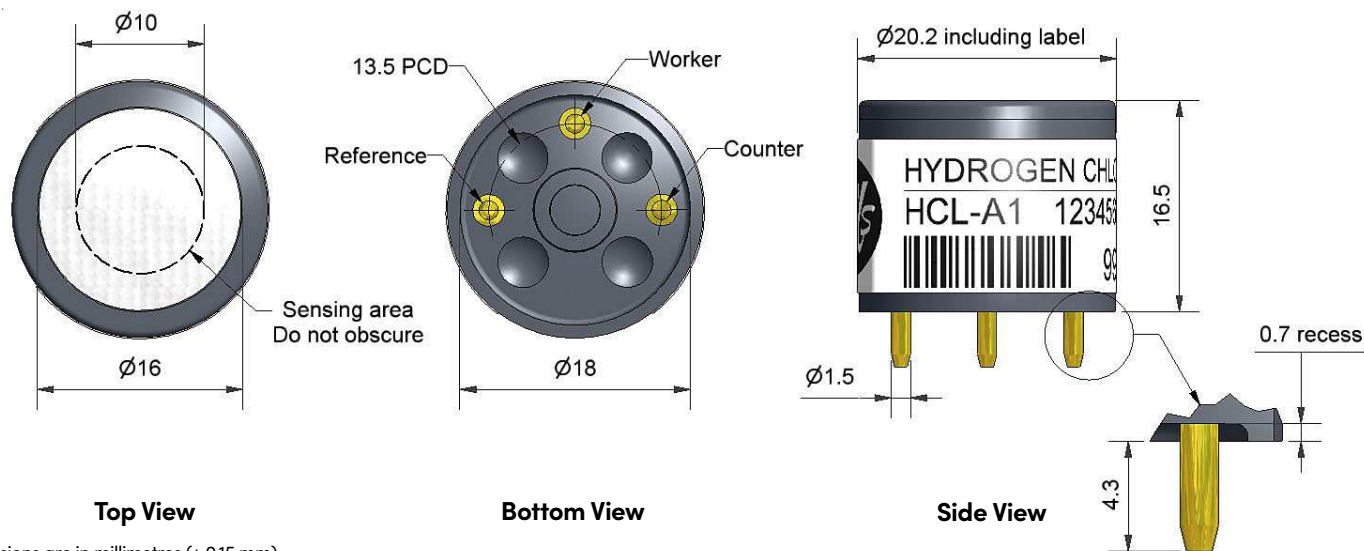

Dimensions are in millimetres ( $\pm 0.15$  mm).

Performance			
Sensitivity	nA/ppm in 25ppm HCl		50 to 140
Response time	t90 (s) from zero to 25ppm HCl		< 300
Zero current	ppm equivalent in zero air		< -3 to 10
Resolution	RMS noise (ppm equivalent)		< 1
Range	ppm HCl limit of performance warranty		100
Linearity	ppm error at full scale, linear at zero, 40ppm HCl		0 to 6
Overgas limit	maximum ppm for stable response to gas pulse		200

Lifetime			
Zero drift	ppm equivalent change/year in lab air		nd
Sensitivity drift	% change/year in lab air, monthly test		nd
Operating life	months until 80% original signal (12-month warranted)		nd

Environmental			
Sensitivity @ -20°C	% (output @ -20°C/output @ 20°C) @ 25ppm HCl		65 to 90
Sensitivity @ 50°C	% (output @ 50°C/output @ 20°C) @ 25ppm HCl		102 to 120
Zero @ -20°C	ppm equivalent change from 20°C		< 0 to 4
Zero @ 50°C	ppm equivalent change from 20°C		< +1 to -5

Cross Sensitivity				
H <sub>2</sub> S sensitivity	% measured gas @ 20ppm	H <sub>2</sub> S		< 250
NO <sub>2</sub> sensitivity	% measured gas @ 50ppm	NO <sub>2</sub>		< -150
Cl <sub>2</sub> sensitivity	% measured gas @ 10ppm	Cl <sub>2</sub>		< -20
NO sensitivity	% measured gas @ 50ppm	NO		< 2
SO <sub>2</sub> sensitivity	% measured gas @ 20ppm	SO <sub>2</sub>		< 0.1
CO sensitivity	% measured gas @ 400ppm	CO		< 0.1
H <sub>2</sub> sensitivity	% measured gas @ 400ppm	H <sub>2</sub>		< 0.1
C <sub>2</sub> H <sub>4</sub> sensitivity	% measured gas @ 400ppm	C <sub>2</sub> H <sub>4</sub>		< 0.1
NH <sub>3</sub> sensitivity	% measured gas @ 20ppm	NH <sub>3</sub>		< 0.1
CO <sub>2</sub> sensitivity	% measured gas @ 5%	CO <sub>2</sub>		< 0.1

Key Specifications			
Temperature range	°C		-30 to +50
Pressure range	kPa		80 to 120
Humidity range	% rh continuous		15 to 90
Storage period	months @ 3 to 20°C (stored in original container)		6
Load resistor	$\Omega$ (recommended)		10 to 33
Bias voltage	mV		not required
Weight	g		< 6

**Figure 1 Response to 25ppm HCl**

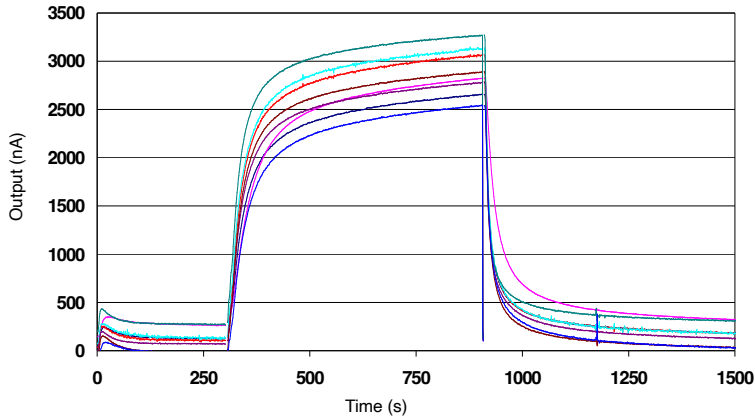

Figure 1 shows the typical response to 25ppm HCl at 20°C.

**Figure 2 Sensitivity Temperature Dependence**

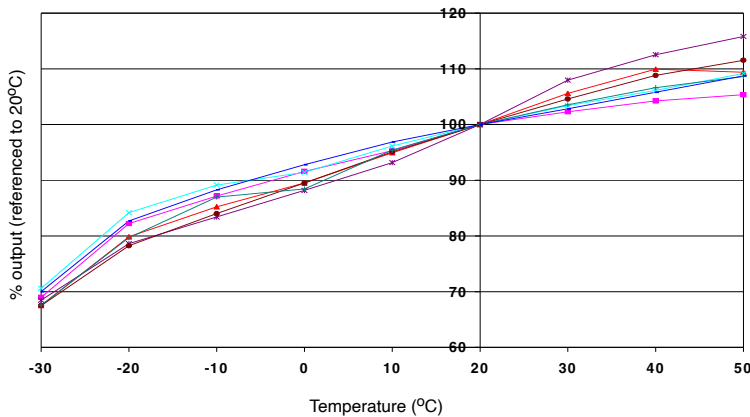

Figure 2 shows the variation in sensitivity caused by changes in temperature. This data is taken from a typical batch of sensors.

**Figure 3 Humidity Transient Response**

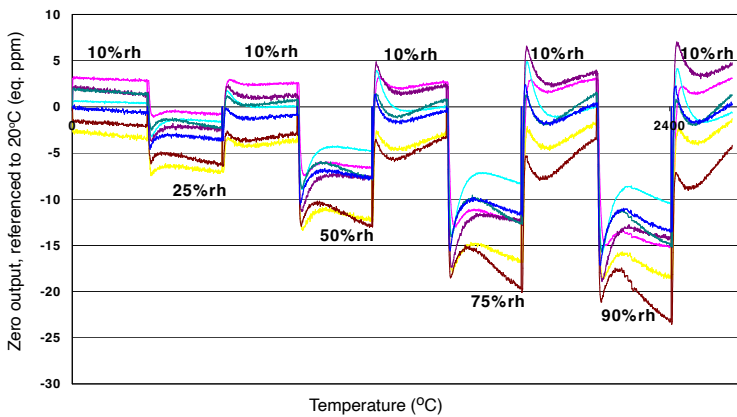

Figure 3 shows transient performance as sensors are subjected to step humidity changes from 10% to 90% rh.

At the end of the product's life, do not dispose of any electronic sensor, component or instrument in the domestic waste, but contact the instrument manufacturer, Alphasense or its distributor for disposal instructions. NOTE: all sensors are tested at ambient environmental conditions unless otherwise stated. As applications of use are outside our control, the information provided is given without legal responsibility. Customers should test under their own conditions, to ensure that the sensors are suitable for their own requirements.

In the interest of continued product improvement, we reserve the right to change design features and specifications without prior notification. The data contained in this document is for guidance only. Alphasense Ltd accepts no liability for any consequential losses, injury or damage resulting from the use of this document or the information contained within. (©ALPHASENSE LTD) Doc. Ref. HCL-A1/SEP22