

## H2S-D4 Hydrogen Sulfide Sensor – Miniature Size

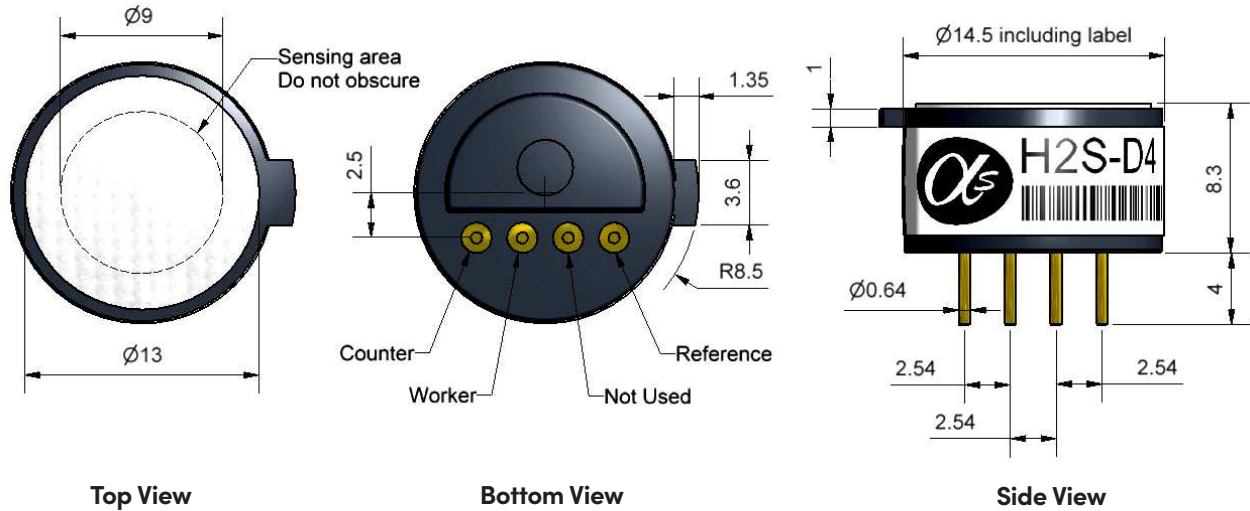

Dimensions are in millimetres ( $\pm 0.1$  mm). A three pin version is available on request, coded H2S-D1.

<b>Performance</b>	Sensitivity	nA/ppm 20ppm H <sub>2</sub> S	110 to 170
	Response time	t <sub>90</sub> (s) from zero to 20ppm H <sub>2</sub> S	< 25
	Zero current	ppm equivalent in zero air	< $\pm 1$
	Resolution	RMS noise (ppm equivalent)	< 0.2
	Range	ppm H <sub>2</sub> S limit of performance warranty	100
	Linearity	ppm error at full scale, linear at zero and 20ppm H <sub>2</sub> S	< $\pm 6$
	Overgas limit	maximum ppm for stable response to gas pulse	200
	<b>Lifetime</b>	Zero drift	ppm equivalent change/year in lab air
Sensitivity drift		% change/year in lab air, monthly test	< 3
Operating life		months until 80% original signal (24-month warranted)	> 18
<b>Environmental</b>	Sensitivity @ -20°C	% (output @ -20°C/output @ 20°C) @ 20ppm	75 to 90
	Sensitivity @ 50°C	% (output @ 50°C/output @ 20°C) @ 20ppm	103 to 112
	Zero @ -20°C	ppm equivalent change from 20°C	< -0.3 to 0.2
	Zero @ 50°C	ppm equivalent change from 20°C	< $\pm 1$
<b>Cross Sensitivity</b>	NO <sub>2</sub> sensitivity	% measured gas @ 10ppm	NO <sub>2</sub> < -25
	Cl <sub>2</sub> sensitivity	% measured gas @ 10ppm	Cl <sub>2</sub> < -25
	NO sensitivity	% measured gas @ 50ppm	NO < 12
	SO <sub>2</sub> sensitivity	% measured gas @ 20ppm	SO <sub>2</sub> < 20
	CO sensitivity	% measured gas @ 400ppm	CO < 2.5
	H <sub>2</sub> sensitivity	% measured gas @ 400ppm	H <sub>2</sub> < 0.5
	C <sub>2</sub> H <sub>4</sub> sensitivity	% measured gas @ 400ppm	C <sub>2</sub> H <sub>4</sub> < 0.15
NH <sub>3</sub> sensitivity	% measured gas @ 20ppm	NH <sub>3</sub> < 0.1	
<b>Key Specifications</b>	Temperature range	°C	-30 to 50
	Pressure range	kPa	80 to 120
	Humidity range	% rh (see note below)	15 to 90
	Storage period	months @ 3 to 20°C (stored in sealed pot)	6
	Load resistor	$\Omega$ (recommended)	10 to 47
	Weight	g	< 2

**Figure 1 Sensitivity Temperature Dependence**

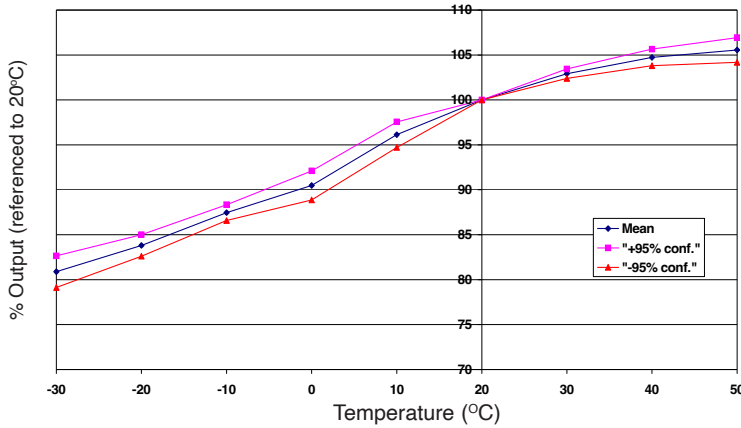

Figure 1 shows the mean and  $\pm 95\%$  confidence intervals for the variation in sensitivity caused by changes in temperature.

The repeatable temperature dependence ranges from  $-30$  to  $+50^\circ\text{C}$  allows more accurate temperature.

**Figure 2 Zero Temperature Dependence**

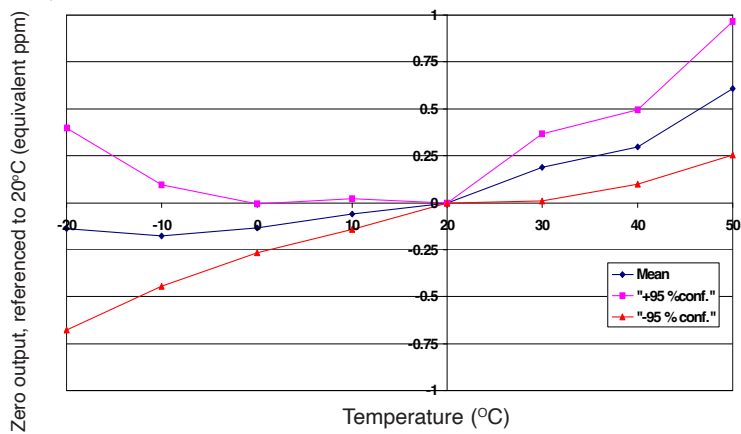

Figure 2 shows the variation in zero output caused by changes in temperature, expressed as ppm gas equivalent, referenced to zero at  $20^\circ\text{C}$ .

This data is taken from a typical batch of sensors. The mean and  $\pm 95\%$  confidence intervals are shown.

**Figure 3 Sensitivity Long-term Stability**

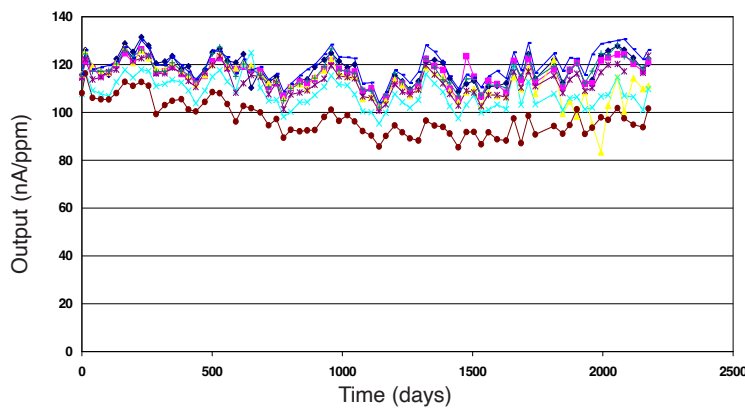

Figure 3 shows the long-term stability of the H2S-D4 sensitivity in ambient air.

Continuous use at low humidities may reduce sensitivity.

Note: Above 85% rh and  $40^\circ\text{C}$  a maximum continuous exposure period of 10 days is warranted. Where such exposure occurs the sensor will recover normal electrolyte volumes when allowed to rest at lower % rh and temperature levels for several days.

At the end of the product's life, do not dispose of any electronic sensor, component or instrument in the domestic waste, but contact the instrument manufacturer, Alphasense or its distributor for disposal instructions. NOTE: all sensors are tested at ambient environmental conditions unless otherwise stated. As applications of use are outside our control, the information provided is given without legal responsibility. Customers should test under their own conditions, to ensure that the sensors are suitable for their own requirements.

In the interest of continued product improvement, we reserve the right to change design features and specifications without prior notification. The data contained in this document is for guidance only. Alphasense Ltd accepts no liability for any consequential losses, injury or damage resulting from the use of this document or the information contained within. (©ALPHASENSE LTD) Doc. Ref. H2S-D4/SEP22