

H2S-B1 Hydrogen Sulfide Sensor

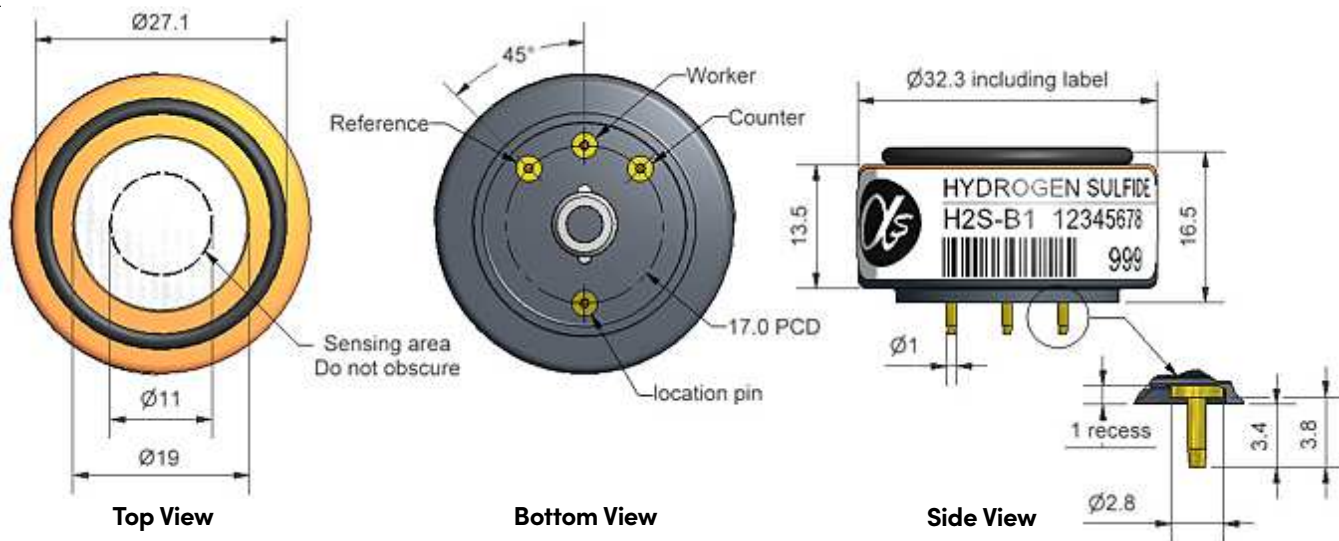

Dimensions are in millimetres (± 0.1 mm).

Performance			
Sensitivity	nA/ppm in 20ppm H ₂ S		300 to 525
Response time	t ₉₀ (s) from zero to 20ppm H ₂ S		< 55
Zero current	ppm equivalent in zero air		± 0.8
Resolution	RMS noise (ppm equivalent)		< 0.05
Range	ppm H ₂ S limit of performance warranty		200
Linearity	ppm error at full scale, linear at zero and 20ppm H ₂ S		1 to -5
Overgas limit	maximum ppm for stable response to gas pulse		500

Lifetime			
Zero drift	ppm equivalent change/year in lab air		< 0.05
Sensitivity drift	% change/year in lab air, monthly test		< 3
Operating life	months until 80% original signal (24-month warranted)		> 24

Environmental			
Sensitivity @ -20°C	% (output @ -20°C/output @ 20°C) @ 20ppm		80 to 92
Sensitivity @ 50°C	% (output @ 50°C/output @ 20°C) @ 20ppm		100 to 110
Zero @ -20°C	ppm equivalent change from 20°C		< ± 0.5
Zero @ 50°C	ppm equivalent change from 20°C		< 0 to 1.5

Cross Sensitivity				
NO ₂ sensitivity	% measured gas @ 10ppm	NO ₂		< -30
Cl ₂ sensitivity	% measured gas @ 10ppm	Cl ₂		< -25
NO sensitivity	% measured gas @ 50ppm	NO		< 35
SO ₂ sensitivity	% measured gas @ 20ppm	SO ₂		< 18
CO sensitivity	% measured gas @ 400ppm	CO		< 3
H ₂ sensitivity	% measured gas @ 400ppm	H ₂		< 0.5
C ₂ H ₄ sensitivity	% measured gas @ 400ppm	C ₂ H ₄		< 0.5
NH ₃ sensitivity	% measured gas @ 400ppm	NH ₃		< 0.1
CO ₂ sensitivity	% measured gas @ 5%	CO ₂		< 0.1

Key Specifications			
Temperature range	°C		-30 to 50
Pressure range	kPa		80 to 120
Humidity range	% rh		15 to 90
Storage period	months @ 3 to 20°C (stored in sealed pot)		6
Load resistor	Ω (recommended)		10 to 47
Weight	g		< 13

Figure 1 Sensitivity Temperature Dependence

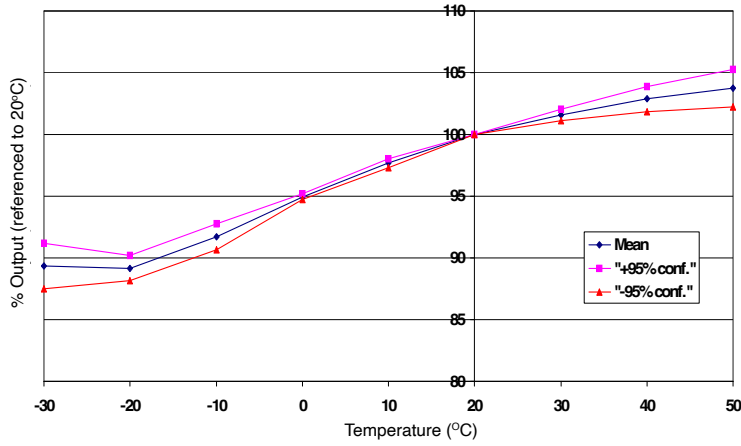

Figure 1 shows the variation in sensitivity caused by changes in temperature.

This data is taken from a typical batch of sensors.

Figure 2 Zero Temperature Dependence

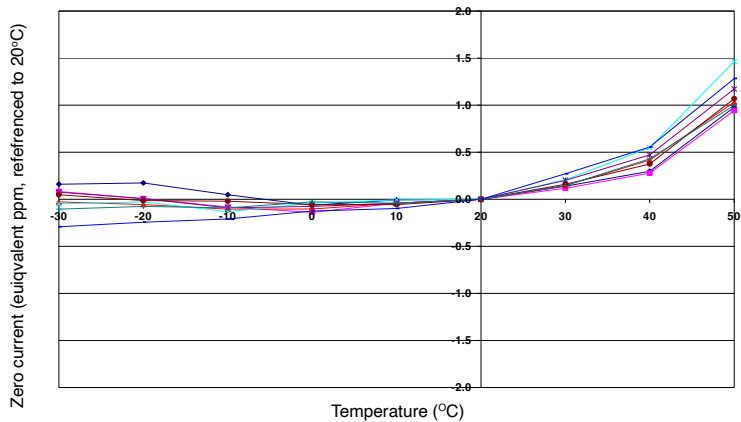
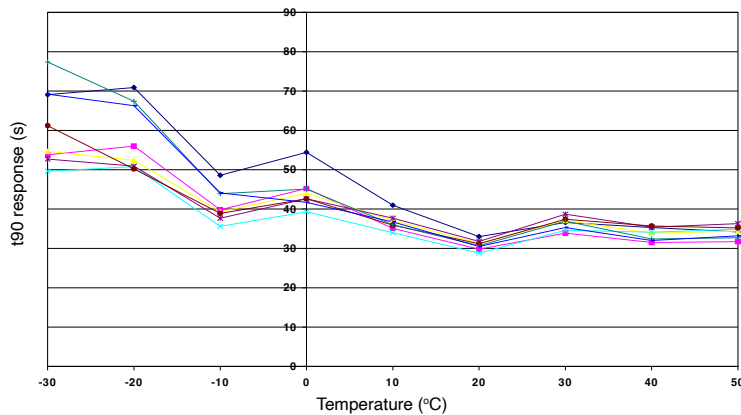

Figure 2 shows the variation in zero output caused by changes in temperature, expressed as ppm gas equivalent, referenced to zero at 20°C.

This data is taken from a typical batch of sensors.

Figure 3 Response Time Temperature Dependence



Electrochemical gas cells respond slower at lower temperatures.

Results are from a standard batch of sensors.

At the end of the product's life, do not dispose of any electronic sensor, component or instrument in the domestic waste, but contact the instrument manufacturer, Alphasense or its distributor for disposal instructions. NOTE: all sensors are tested at ambient environmental conditions unless otherwise stated. As applications of use are outside our control, the information provided is given without legal responsibility. Customers should test under their own conditions, to ensure that the sensors are suitable for their own requirements.

In the interest of continued product improvement, we reserve the right to change design features and specifications without prior notification. The data contained in this document is for guidance only. Alphasense Ltd accepts no liability for any consequential losses, injury or damage resulting from the use of this document or the information contained within. (©ALPHASENSE LTD) Doc. Ref. H2S-B1/SEP22