

H2O2-A1 Hydrogen Peroxide Sensor

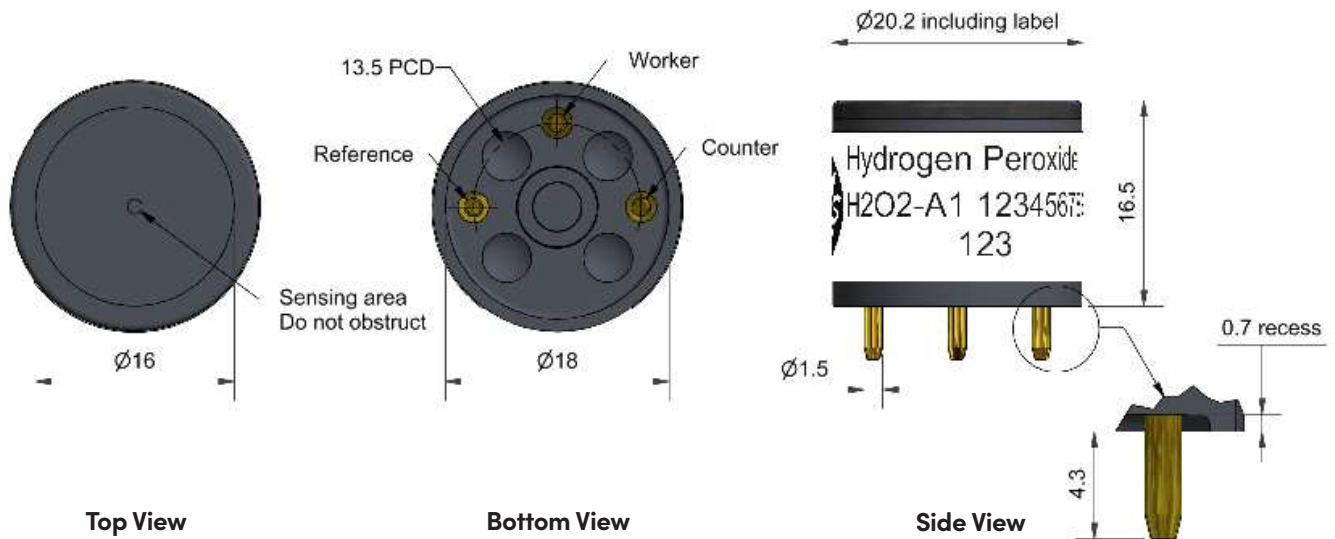

Dimensions are in millimetres (± 0.1 mm).

Performance

Sensitivity	nA/ppm in 400ppm CO	50 to 90
Response time	t90 (s) from zero to 400ppm CO	< 25
Zero current	ppm equivalent in zero air	-4 to +3
Resolution	RMS noise (ppm equivalent)	< 0.5
Range	ppm CO limit of performance warranty	2,000
Linearity	ppm error at full scale, linear at zero, 400ppm CO	+15 to + 25
Overgas limit	maximum ppm for stable response to gas pulse	5,000

Lifetime

Zero drift	ppm equivalent change/year in lab air	< 0.2
Sensitivity drift	% change/year in lab air, monthly test	< 8
Operating life	months until 80% original signal (24-month warranted)	> 24

Environmental

Sensitivity @ -20°C	% (output @ -20°C/output @ 20°C) @ 400ppm CO	70 to 88
Sensitivity @ 50°C	% (output @ 50°C/output @ 20°C) @ 400ppm CO	102 to 115
Zero @ -20°C	ppm equivalent change from 20°C	< ± 3
Zero @ 50°C	ppm equivalent change from 20°C	< ± 8

Cross Sensitivity

H ₂ S sensitivity	% measured gas @ 20ppm	H ₂ S	< 350
NO ₂ sensitivity	% measured gas @ 10ppm	NO ₂	< -20
Cl ₂ sensitivity	% measured gas @ 10ppm	Cl ₂	< 60
NO sensitivity	% measured gas @ 50ppm	NO	< 30
SO ₂ sensitivity	% measured gas @ 20ppm	SO ₂	< 35
H ₂ sensitivity	% measured gas @ 400ppm	H ₂ at 20°C	< 85
C ₂ H ₄ sensitivity	% measured gas @ 400ppm	C ₂ H ₄	< 150
NH ₃ sensitivity	% measured gas @ 20ppm	NH ₃	< 0.1

Key Specifications

Temperature range	°C	-30 to 50
Pressure range	kPa	80 to 120
Humidity range	% rh continuous	15 to 90
Storage period	months @ 3 to 20°C (stored in sealed pot)	6
Load resistor	Ω (recommended)	10 to 47
Weight	g	< 6

Figure 1 Sensitivity Temperature Dependence

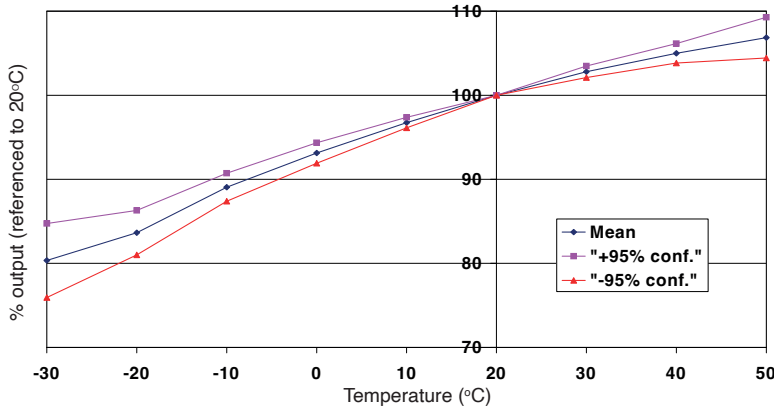

Figure 1 shows the variation in sensitivity caused by changes in temperature.

This data is taken from a typical batch of sensors. The mean and $\pm 95\%$ confidence intervals are shown.

Figure 2 Zero Temperature Dependence

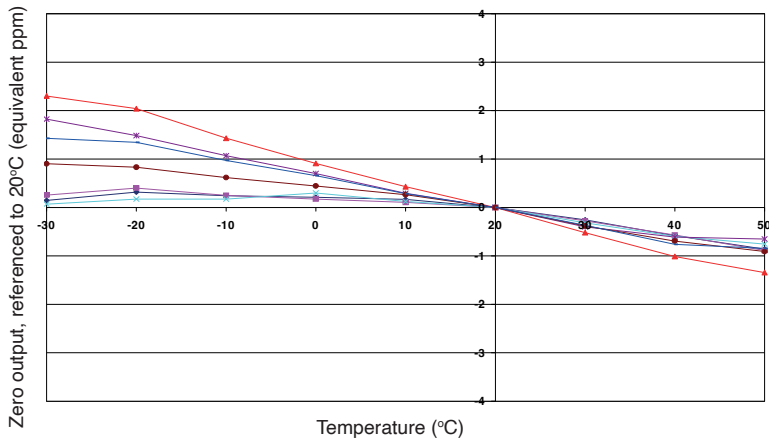

Figure 2 shows the variation in zero output caused by changes in temperature, expressed as ppm gas equivalent, referenced to zero at 20°C.

This data is taken from a typical batch of sensors.

Figure 3 Response to Exposure to 2% CO

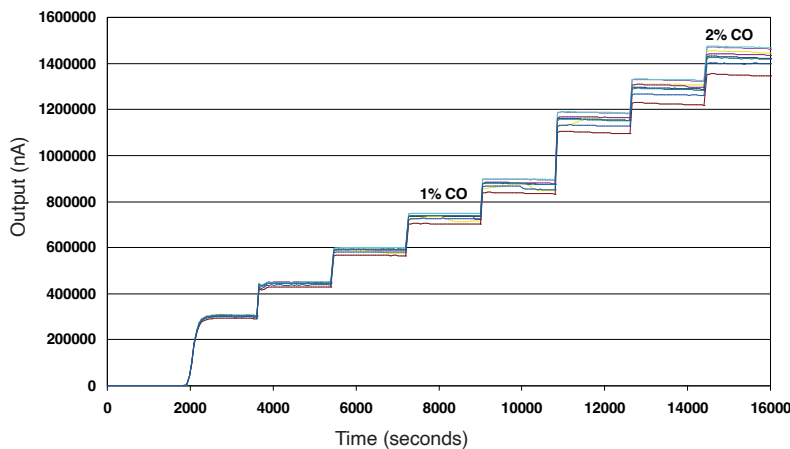

Figure 3 shows the excellent response to step changes in CO concentrations from zero to 2% CO by volume.

This data is taken from a typical batch of sensors.

At the end of the product's life, do not dispose of any electronic sensor, component or instrument in the domestic waste, but contact the instrument manufacturer, Alphasense or its distributor for disposal instructions. NOTE: all sensors are tested at ambient environmental conditions unless otherwise stated. As applications of use are outside our control, the information provided is given without legal responsibility. Customers should test under their own conditions, to ensure that the sensors are suitable for their own requirements.

In the interest of continued product improvement, we reserve the right to change design features and specifications without prior notification. The data contained in this document is for guidance only. Alphasense Ltd accepts no liability for any consequential losses, injury or damage resulting from the use of this document or the information contained within. ©ALPHASENSE LTD) Doc. Ref. H2O2-A1/SEP22