

ETO-B1 Ethylene Oxide Sensor

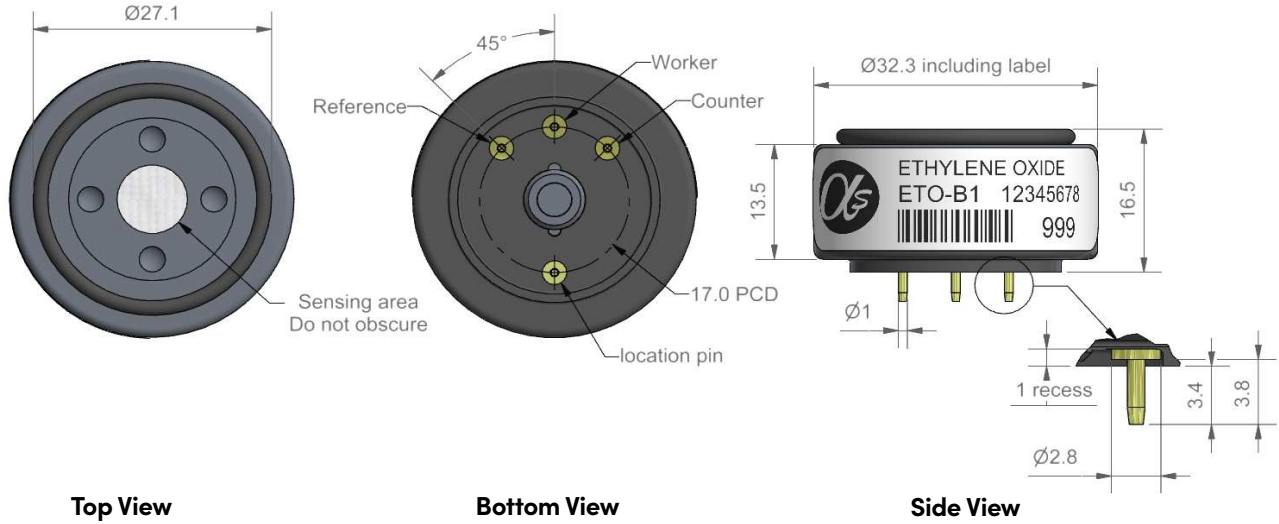

Top View

Bottom View

Side View

Dimensions are in millimetres (± 0.1 mm).

Performance

Sensitivity	nA/ppm in 20ppm EtO	2,000 to 3,400
Response time	t90 (s) from zero to 20ppm EtO	< 200
Zero current	ppm equivalent in zero air	< -0.6 to +1
Resolution	RMS noise (ppm equivalent)	< 0.1
Range	ppm EtO limit of performance warranty	100
Linearity	ppm error at full scale, linear at zero, 40ppm EtO	5 to 10
Overgas limit	maximum ppm for stable response to gas pulse	500

Lifetime

Zero drift	ppm equivalent change/year in lab air	nd
Sensitivity drift	% change/year in lab air, twice monthly test	nd
Operating life	months until 80% original signal (24-month warranted)	> 24

Environmental

Sensitivity @ -20°C	(% output @ -20°C/output @ 20°C) @ 50ppm CO	20 to 50
Sensitivity @ 50°C	(% output @ 50°C/output @ 20°C) @ 50ppm CO	120 to 160
Zero @ -20°C	ppm equivalent change from 20°C	< ± 0.5
Zero @ 50°C	ppm equivalent change from 20°C	< +2 to +5

Cross Sensitivity

H ₂ S sensitivity	% measured gas @ 20ppm	H ₂ S	< 200
NO ₂ sensitivity	% measured gas @ 10ppm	NO ₂	< 35
Cl ₂ sensitivity	% measured gas @ 10ppm	Cl ₂	< -3
NO sensitivity	% measured gas @ 50ppm	NO	< 80
SO ₂ sensitivity	% measured gas @ 20ppm	SO ₂	< 40
CO sensitivity	% measured gas @ 40ppm	CO	< 25
H ₂ sensitivity	% measured gas @ 400ppm	H ₂	< 0.5
C ₂ H ₄ sensitivity	% measured gas @ 80ppm	C ₂ H ₄	< 100
NH ₃ sensitivity	% measured gas @ 25ppm	NH ₃	< 0.1
HCHO sensitivity	% measured gas @ 4ppm	HCHO	90
CO ₂ sensitivity	% measured gas @ 5% volume	CO ₂	< 0.1

Key Specifications

Temperature range	°C	-30 to 50
Pressure range	kPa	80 to 120
Humidity range	% rh continuous	15 to 90
Storage period	months @ 3 to 20°C (stored in original container)	6
Load resistor	Ω (recommended)	10 to 33
Bias voltage	mV (working electrode potential above reference electrode potential)	300
Weight	g	< 13

Figure 1 Sensitivity Temperature Dependence

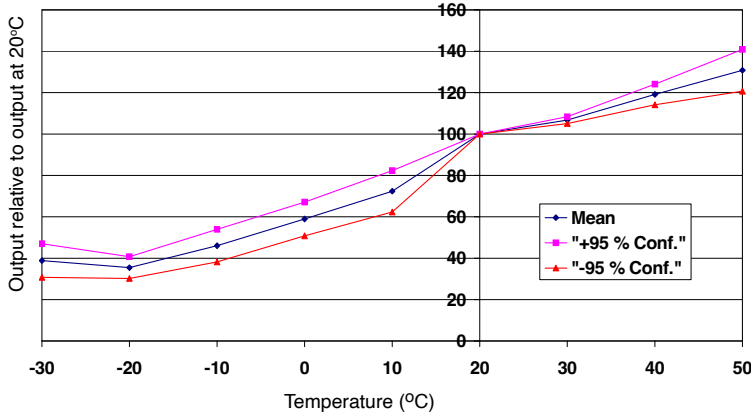

Figure 1 shows the variation in sensitivity caused by changes in temperature.

This data is taken from a typical batch of sensors. The mean and $\pm 95\%$ confidence intervals are shown.

Figure 2 Zero Temperature Dependence

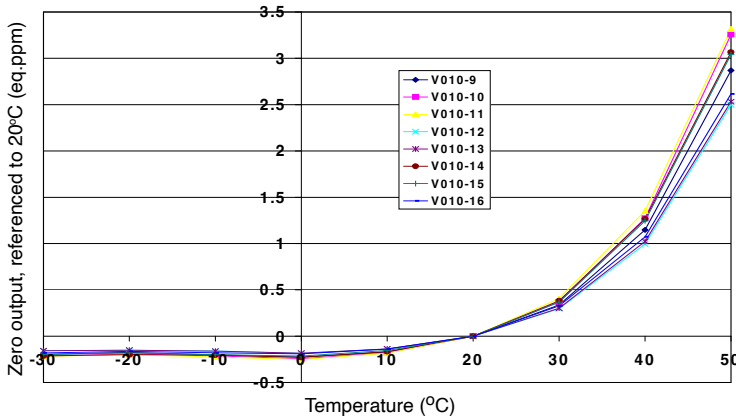
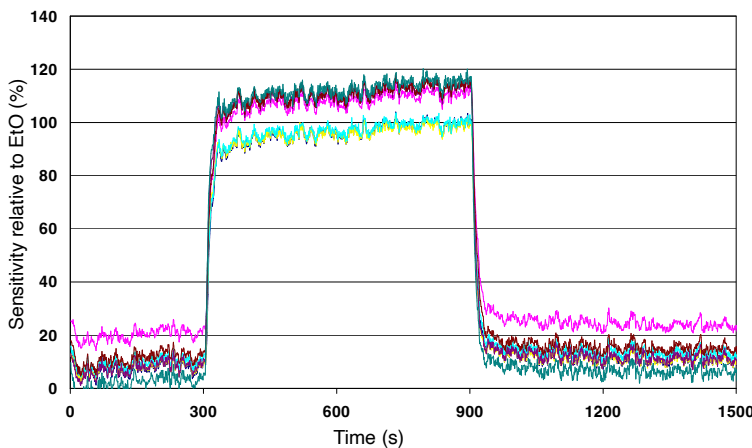

Figure 2 shows the variation in zero output caused by changes in temperature, expressed as ppm gas equivalent, referenced to zero at 20°C.

This data is taken from a typical batch of sensors.

Figure 3 Cross Sensitivity Study to 3.8 ppm Formaldehyde



The ETO-B1 responds to most VOCs that are electrochemically active.

The bias voltage of +300mV is optimum for Ethylene Oxide but needs adjusting when measuring other VOCs.

Response to formaldehyde with +300mV bias is shown.

At the end of the product's life, do not dispose of any electronic sensor, component or instrument in the domestic waste, but contact the instrument manufacturer, Alphasense or its distributor for disposal instructions. NOTE: all sensors are tested at ambient environmental conditions unless otherwise stated. As applications of use are outside our control, the information provided is given without legal responsibility. Customers should test under their own conditions, to ensure that the sensors are suitable for their own requirements.

In the interest of continued product improvement, we reserve the right to change design features and specifications without prior notification. The data contained in this document is for guidance only. Alphasense Ltd accepts no liability for any consequential losses, injury or damage resulting from the use of this document or the information contained within. (©ALPHASENSE LTD) Doc. Ref. ETO-B1/SEP22